



# **Bulletin 1203**

## **Serial Communications Module**

**RS232/422/485 (Using DF1 Protocol)**  
Catalog Number 1203-GD2, -GK2, -GM2

User Manual



Spare Allen-Bradley Parts

## Important User Information

Because of the variety of uses for this equipment and because of the differences between this solid-state equipment and electromechanical equipment, the user of and those responsible for applying this equipment must satisfy themselves as to the acceptability of each application and use of the equipment. In no event will Allen-Bradley Company be responsible or liable for indirect or consequential damages resulting from the use or application of this equipment.

The illustrations shown in this manual are intended solely to illustrate the text of this manual. Because of the many variables and requirements associated with any particular installation, the Allen-Bradley Company cannot assume responsibility or liability for actual use based upon the illustrative uses and applications.

No patent liability is assumed by Allen-Bradley Company with respect to use of information, circuits or equipment described in this text.

Reproduction of the content of this manual, in whole or in part, without written permission of the Allen-Bradley Company is prohibited.

This information in this manual is organized in numbered chapters. Read each chapter in sequence and perform procedures when you are instructed to do so. Do not proceed to the next chapter until you have completed all procedures.



**ATTENTION:** Identifies information about practices or circumstances that can lead to personal injury or death, property damage or economic loss.

---

Attentions help you:

- identify a hazard
- avoid the hazard
- recognize the consequences

**IMPORTANT:** Identifies information that is especially important for successful application and understanding of the product.

## Summary Information

These changes have been made since any preliminary photocopy documents were issued:

### Chapter 1

A trademark symbol has been added to 1336 PLUS on page 1-1.

### Chapter 2

- The word “board” has been changed to “module” in the last sentence of paragraph four on page 2-1.
- The word “Default” has been added to the description of SW3.7, SW3.8 in, and DH-485 has been removed from, Figure 2.1 on page 2-2.
- The SLC 5/03 illustration in Figure 2.3 on page 2-4 has been reduced 50 percent.

### Chapter 3

- The note on page 3-9 has been replaced with a new note.
- The Figure 3.2 heading on page 3-11 has been changed to include 1336 PLUS.
- The 9-pin D-shell in Figure 3.6 on page 3-14 has been changed to match the same in Figure 3.5.
- The range (7.5 – 500HP) has been removed from the first heading on page 3-17.

### Chapter 5

- Three new tables have replaced Table 5.B on page 5-3.
- The first paragraph on page 5-4 has been changed to accommodate the three new tables preceding this text.
- A sentence has been added to the end of Item 3, Parameter Read Full, on page 5-4.
- The Item 8 heading, System File, on page 5–5, has been changed to System Area.

### Chapter 6

- The Figure 5.1 heading on page 6-1 has been changed to Figure 6-1, and the figure reference in the first paragraph has changed likewise.
- The Table 5.C heading on page 6-2 has changed to Table 6.A.

### Notes

A Notes section has been added to the end of this document.

Summary of Changes

**This Page Intentionally Left Blank**

<b>Introduction</b>	<b>Chapter 1</b>	
	Manual Objectives .....	1-1
	Who Should Use This Manual .....	1-1
	Vocabulary .....	1-1
	Firmware Support .....	1-1
	Manual Organization .....	1-2
	Safety Precautions .....	1-2
	Serial Device Compatibility .....	1-3
<b>Product Description</b>	<b>Chapter 2</b>	
	Chapter Objectives .....	2-1
	Module Description .....	2-1
	SCANport Device Compatibility .....	2-2
	Configuration Switches .....	2-5
<b>Installation</b>	<b>Chapter 3</b>	
	Chapter Objectives .....	3-1
	Setting Module Configuration Switches .....	3-1
	Factory Switch Settings .....	3-2
	Switch SW1 .....	3-3
	Switch SW2 .....	3-6
	Switch SW3 .....	3-8
	Mounting the Communications Module .....	3-10
	Enclosed Style Communications Module Dimensions .....	3-12
	Cable Connections .....	3-13
	RS485/RS422/RS232 Connection Examples .....	3-13
	SCANport Link Connection .....	3-16
	Cable Requirements .....	3-16
	1305 Drive .....	3-16
	1336 PLUS and 1336 FORCE .....	3-17
	SMP 3 .....	3-17
	Power Supply Connections .....	3-18
<b>SCANport Datalink Operation</b>	<b>Chapter 4</b>	
	Chapter Objectives .....	4-1
	SCANport Datalinks .....	4-1

<b>Configuration and Interfacing</b>	<b>Chapter 5</b>	
	Chapter Objectives . . . . .	5-1
	Basic Operation . . . . .	5-1
	Communications Module Data Table Structure and Supported PCCC Command List . . . . .	5-1
	Configuration Examples . . . . .	5-8
	DF1 Messaging with a PLC-5/80 Example (Read Parameters 1 through 50) . . . . .	5-8
	DF1 Messaging with a 1746-BAS Module Example (Write 10 Parameters then read 10 parameters) . . . . .	5-10
<b>Troubleshooting</b>	<b>Chapter 6</b>	
	Chapter Objectives . . . . .	6-1
<b>Specifications</b>	<b>Chapter 7</b>	
	Chapter Objectives . . . . .	7-1
	Product Specifications . . . . .	7-1
	Module Compatibility . . . . .	7-1

PLC, PLC-2, PLC-3, and PLC-5 are registered trademarks of Allen-Bradley Company, Inc.  
 SMC, PLC-2/30, PLC-5/10, PLC-5/15, PLC-5/25, PLC-5/30, PLC-5/40, PLC-5/40L, PLC-5/60L, PLC-5/80, and PLC-5/250 are trademarks of Allen-Bradley Company, Inc.  
 SCANport is a registered trademark of Allen-Bradley Company, Inc.  
 SLC 500, SLC-5/02, and SLC-5/03 are registered trademarks of Allen-Bradley Company, Inc.

## Introduction

### Manual Objectives

The purpose of this manual is to provide you with the necessary information to apply the Serial Communications Module which is available for products that include the SCANport™ communications port. Described in this manual are methods for installing, configuring, and troubleshooting the Serial Communications Module.

For information on specific features of Allen-Bradley products mentioned herein, refer to the product user manual.

**IMPORTANT:** This manual should be read in its entirety before installing, operating, servicing, or initializing the Serial Communications Module.

### Who Should Use This Manual

This manual is intended for qualified service personnel responsible for setting up and servicing of these devices. You must have previous experience with and a basic understanding of communications terminology, configuration procedures, required equipment, and safety precautions.

To make efficient use of this Communications Module, you must be able to program and operate serial communications devices, as well as have a basic understanding of the parameter settings and functions of the device to which you are communicating.

### Vocabulary

In this manual we refer to the:

- Serial Communications Module as “Communications Module.”
- Variable Frequency AC Drive (Bulletin 1305, 1336 FORCE™, or 1336 PLUS™) as the “Drive” or “SCANport device”.
- Programmable Logic Controller as the “Programmable Controller” or “PLC”.
- Earth Ground as “GND”.

### Firmware Support

This manual supports communications module firmware versions 1.xx (the “xx” designator may vary). Features that work with specific firmware versions will be denoted as such.

## Manual Organization

This manual is divided into chapters as detailed in Table 1.A.

**Table 1.A**  
**Manual Organization and Topics**

Chapter	Title	Topics Covered	Related Tasks
1	Introduction	Manual objectives, audience, vocabulary, firmware support information, manual organization, safety precautions, and serial device compatibility	
2	Product Description	Communications Module features, configuration, and diagnostics	
3	Installation	Mounting, power connections, switch configuration, cabling, and hardware	
4	SCANport Datalink Operation	Configuring SCANport device Datalinks, Datalink operation	
5	Configuration and Interfacing	Addressing, information transfer, and sample programs	
6	Troubleshooting	LED indications and fault descriptions	
7	Specifications	Environmental, electrical, and communications specifications	

## Safety Precautions



**ATTENTION:** Only personnel familiar with SCANport devices and associated machinery should plan or implement the installation, start-up, configuration, and subsequent maintenance of the serial communications module. Failure to comply may result in personal injury and/or equipment damage.



**ATTENTION:** This Module contains ESD (Electrostatic Discharge) sensitive parts and assemblies. Static control precautions are required when installing, testing, servicing, or repairing this assembly. Component damage may result if ESD control procedures are not followed. If you are not familiar with static control procedures, reference Allen-Bradley Publication 8000-4.5.2, *Guarding Against Electrostatic Damage* or any other applicable ESD protection handbook.



## Serial Device Compatibility

This Communications Module is intended for use with devices that communicate via the following protocols:

Hardware Standard	Communications Protocol
RS232	DF1
RS422	DF1
RS485	DF1

**IMPORTANT:** “DF1” protocol is typically used with Allen-Bradley PLC<sup>®</sup> programmable controllers.

**This Page Intentionally Left Blank.**

## Product Description

### Chapter Objectives

In this chapter, you will read about:

- Communications Module features
- Location of configuration switches

### Module Description

The Serial Communications Module is an optional interface device designed to provide a direct, digital link between serial communications devices and any device that uses SCANport. The current list of products that use SCANport includes: 1305, 1336 PLUS, 1336 FORCE, and SMP3 controllers. The module connects to these products through the SCANport port.

The Communications Module is available in both Open style (Figure 2.1) and Enclosed (Figure 2.2) type configurations. The Open style module mounts inside certain drives, depending on drive size (see Table 2.A for details). The Enclosed module mounts independently and can be used with any compatible SCANport device.

**Table 2.A**  
Serial Device Configurations

Designation	Enclosure	Power Supply Source	Used With:
Open Style	Open PC Board	Supplied by Drive	1336 PLUS* 1336 FORCE**
Enclosed	IP30	24V DC separately supplied or 120/240V AC separately supplied	1305 1336 PLUS 1336 FORCE SMP3 Other SCANport products

\* 7.5HP and higher sizes only

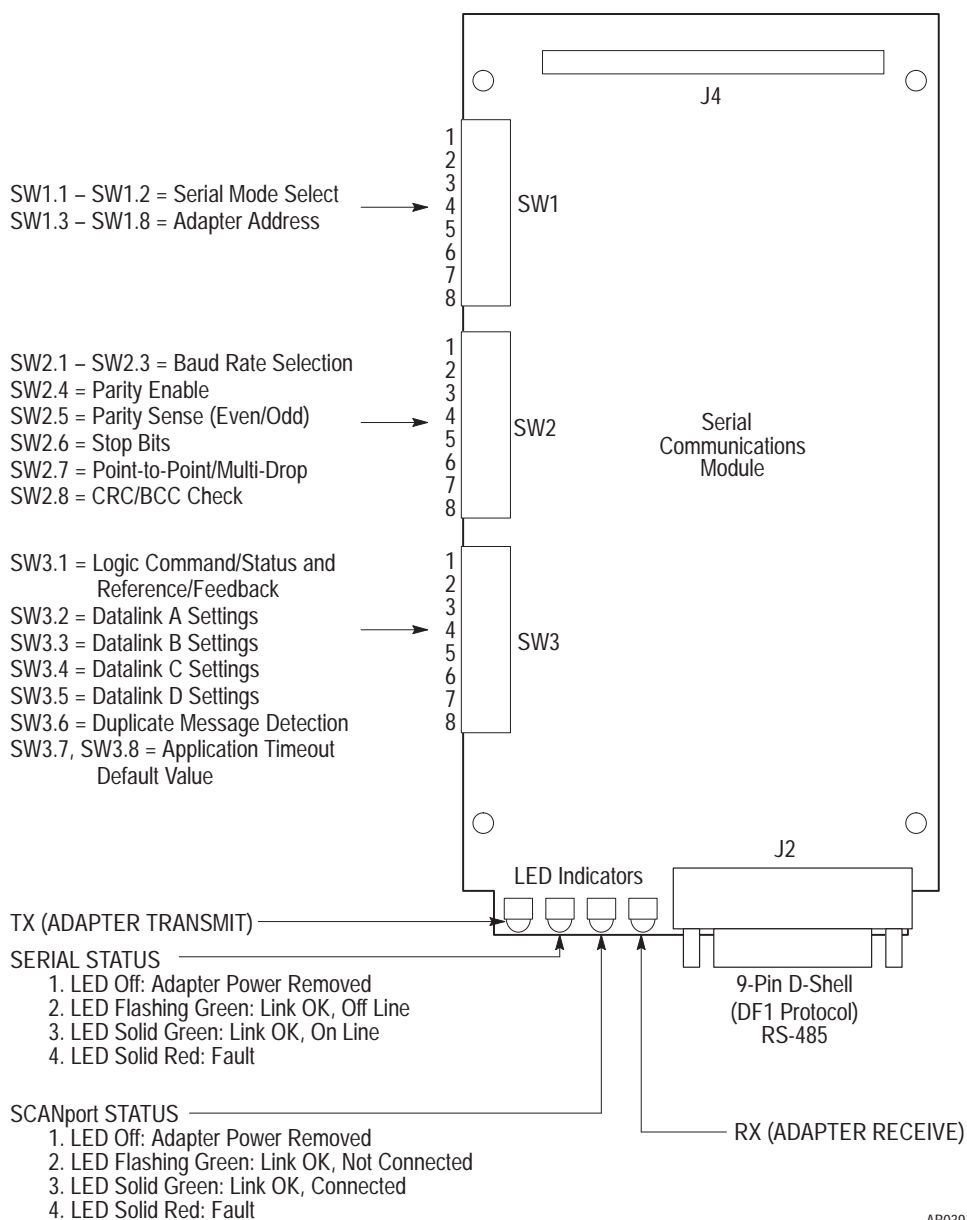
\*\* 7.5HP and higher sizes with Standard Adapter board only

## SCANport Device Compatibility

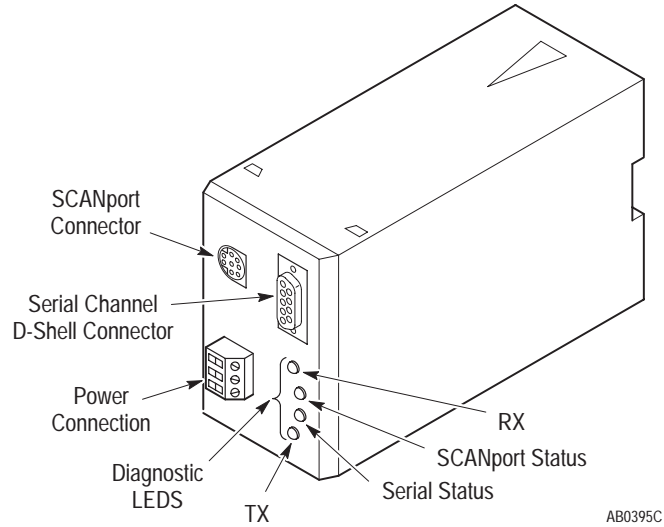
The SCANport Serial Communications Module is compatible with the following Allen-Bradley devices:

Device	Firmware Revision
1336 PLUS	All
1336 FORCE	All
1305 MicroDrive	2.0 or newer
SMC	
SMP	

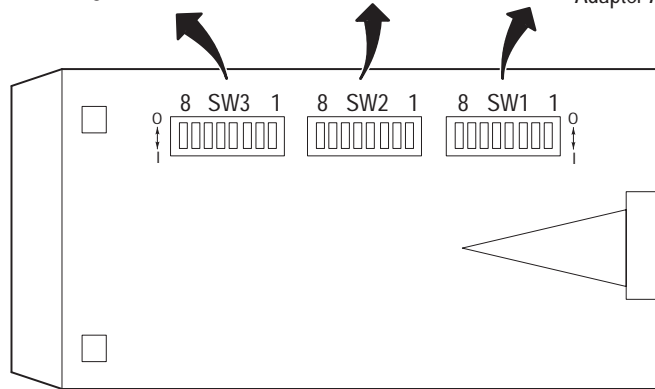
**Figure 2.1**  
**Open Style Communications Module**



**Figure 2.2**  
**Enclosed Style Serial-to-SCANport Communications Module**

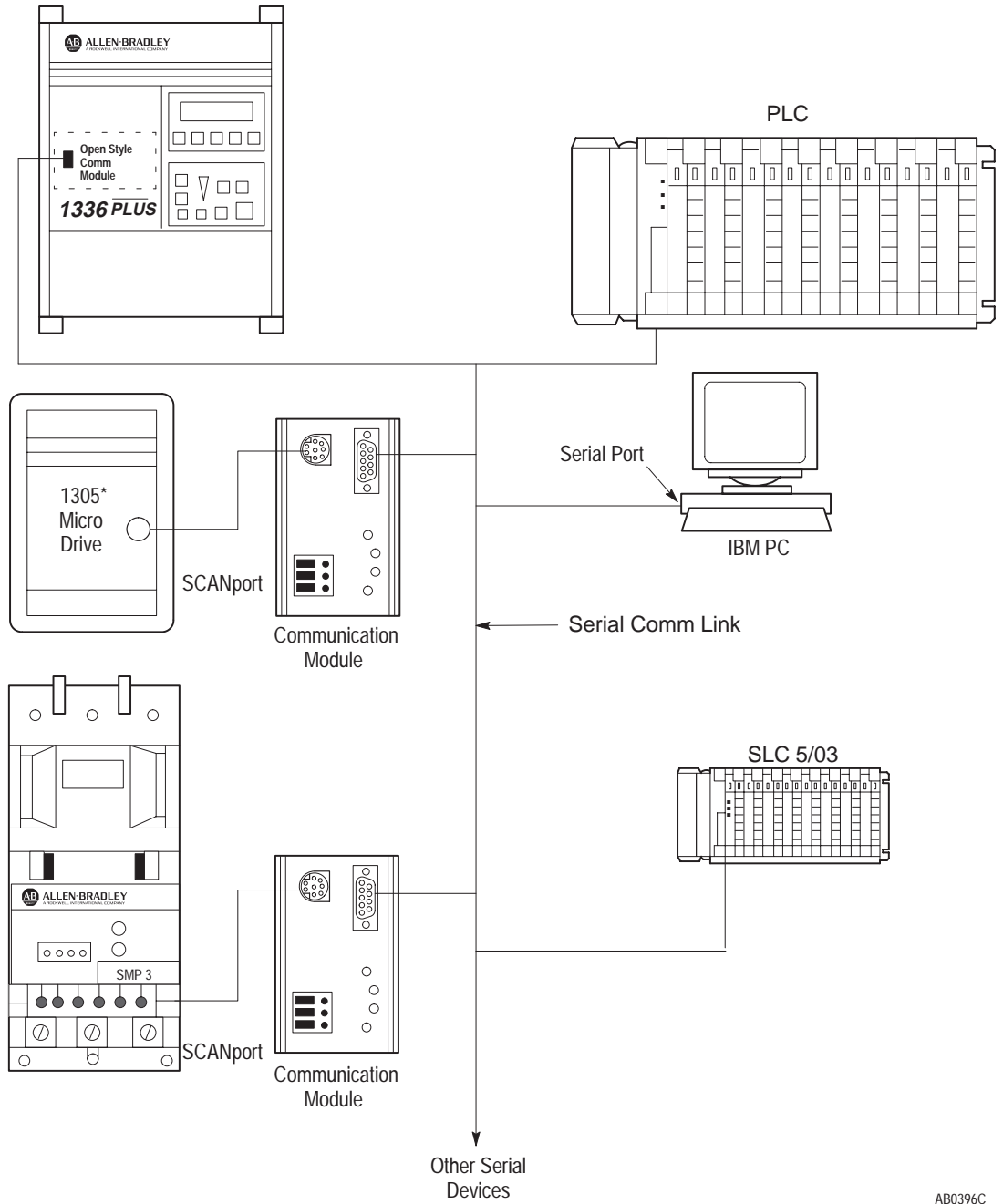


- Switch SW3
  - Logic Command/Status and Reference/Feedback
  - Datalink A, B, C, D Settings
  - Application Timeout
  - Default Value
  - Duplicate Message Detection
- Switch SW2
  - Baud Rate Selection
  - Parity Enable
  - Parity Sense (Even/Odd)
  - Stop Bits
  - Point-to-Point/Multi-Drop
  - CRC/BCC Check
- Switch SW1
  - Serial Mode Select
  - Adapter Address



**BOTTOM VIEW**

Figure 2.3  
Typical Serial Communications/SCANport Device Interconnect

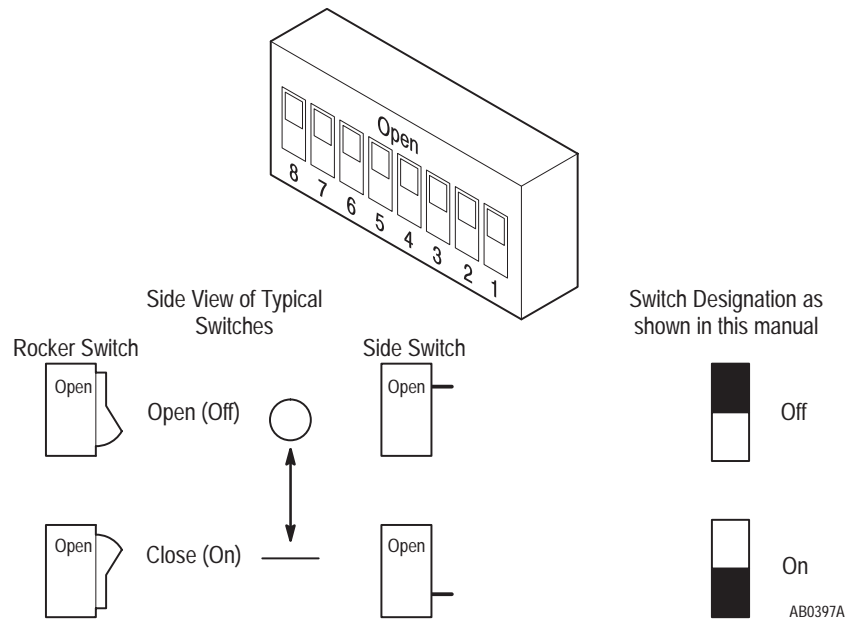


AB0396C

## Configuration Switches

The Serial Communications Module contains three DIP Switches: SW1, SW2, and SW3 (Figure 2.1 and Figure 2.2). Switches are set ON or OFF as detailed in Figure 2.4. For a detailed explanation of switch configuration, refer to Chapter 3.

Figure 2.4  
Configuration Switches



**This Page Intentionally Left Blank.**



## Installation

### Chapter Objectives

In this chapter you will learn how to:

- Mount the Communications Module
- Configure the Communications Module
- Connect power
- Connect SCANport and serial communications cables

Read this chapter completely before you attempt to install or configure your Communications Module. Double check all connections and option selections before you apply power.

**IMPORTANT:** Switch selections take effect only on power-up. If selections are changed after power is applied, cycle the power to use the new settings.

### Setting Module Configuration Switches

This publication describes switches as being either on or off. If the switch assembly has the word OPEN printed on it, the word OPEN corresponds to OFF (0).

When making configuration changes to the Communications Module, use the addressing conventions of the PLC/SLC processor or serial device through which you are communicating. In all cases, each serial device must have a unique address the target processor can recognize.



**ATTENTION:** When you make changes to the switch settings, use a blunt, pointed instrument such as a ball point pen. Do not use a pencil because the lead (graphite) of the pencil may damage the switch assembly.

---



**ATTENTION:** Failure to check connections and switch settings for compatibility with your application when configuring the communications module could result in personal injury and/or equipment damage due to unintended or undesirable operation.

---



**ATTENTION:** It is recommended that when a system is configured for the first time, that the motor be disconnected from the machine or process during initial testing.

---

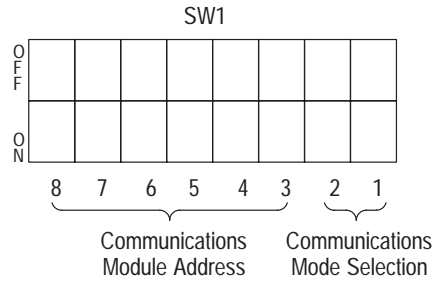
### Factory Switch Settings

Switch	Setting	Communication Mode
SW1-8	Off	Module Address = 1
SW1-7	Off	
SW1-6	Off	
SW1-5	Off	
SW1-4	Off	
SW1-3	On	
SW1-2	Off	RS232 (DF1 Protocol)
SW1-1	Off	
SW2-8	Off	BCC Checksum
SW2-7	Off	Point-to-Point
SW2-6	Off	1 Stop Bit
SW2-5	Off	Parity Disabled
SW2-4	Off	Even Parity (if enabled)
SW2-3	On	9600 Baud
SW2-2	On	
SW2-1	Off	
SW3-8	Off	No Application Timeout (Disabled)
SW3-7	Off	
SW3-6	On	Duplicate Message Detection Enabled
SW3-5	Off	Disable Datalink D
SW3-4	Off	Disable Datalink C
SW3-3	Off	Disable Datalink B
SW3-2	Off	Disable Datalink A
SW3-1	Off	Disable Logic Command/Status and Reference/Feedback

### Switch SW1

Switch SW1 is used to select:

- Serial communications mode (RS232/RS422/RS485)
- Communications Module address



AB0398B

**Table 3.A**  
**Switch SW1 Settings for Communications Mode**

Switch Value (Decimal)	SW1-2	SW1-1	Communications Mode
0	Off	Off	RS232 (DF1 Protocol)
1	Off	On	RS422 (DF1 Protocol)
2	On	Off	RS485 (DF1 Protocol)
3	On	On	Not Used

Table 3.B  
Switch SW1 Settings for Serial Device Addressing

Module Address (Decimal)	Module Address (Octal)	SW1-8	SW1-7	SW1-6	SW1-5	SW1-4	SW1-3
0	0	Off	Off	Off	Off	Off	Off
1	1	Off	Off	Off	Off	Off	On
2	2	Off	Off	Off	Off	On	Off
3	3	Off	Off	Off	Off	On	On
4	4	Off	Off	Off	On	Off	Off
5	5	Off	Off	Off	On	Off	On
6	6	Off	Off	Off	On	On	Off
7	7	Off	Off	Off	On	On	On
8	10	Off	Off	On	Off	Off	Off
9	11	Off	Off	On	Off	Off	On
10	12	Off	Off	On	Off	On	Off
11	13	Off	Off	On	Off	On	On
12	14	Off	Off	On	On	Off	Off
13	15	Off	Off	On	On	Off	On
14	16	Off	Off	On	On	On	Off
15	17	Off	Off	On	On	On	On
16	20	Off	On	Off	Off	Off	Off
17	21	Off	On	Off	Off	Off	On
18	22	Off	On	Off	Off	On	Off
19	23	Off	On	Off	Off	On	On
20	24	Off	On	Off	On	Off	Off
21	25	Off	On	Off	On	Off	On
22	26	Off	On	Off	On	On	Off
23	27	Off	On	Off	On	On	On
24	30	Off	On	On	Off	Off	Off
25	31	Off	On	On	Off	Off	On
26	32	Off	On	On	Off	On	Off
27	33	Off	On	On	Off	On	On
28	34	Off	On	On	On	Off	Off
29	35	Off	On	On	On	Off	On
30	36	Off	On	On	On	On	Off
31	37	Off	On	On	On	On	On
32	40	On	Off	Off	Off	Off	Off
33	41	On	Off	Off	Off	Off	On
34	42	On	Off	Off	Off	On	Off
35	43	On	Off	Off	Off	On	On
36	44	On	Off	Off	On	Off	Off
37	45	On	Off	Off	On	Off	On
38	46	On	Off	Off	On	On	Off
39	47	On	Off	Off	On	On	On
40	50	On	Off	On	Off	Off	Off
41	51	On	Off	On	Off	Off	On

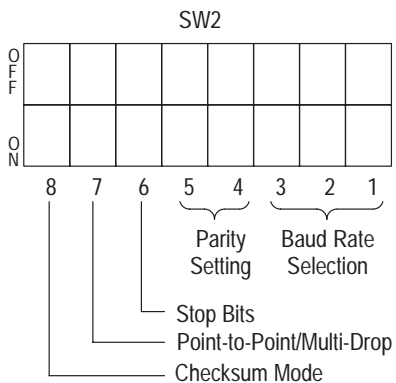
Module Address (Decimal)	Module Address (Octal)	SW1-8	SW1-7	SW1-6	SW1-5	SW1-4	SW1-3
42	52	On	Off	On	Off	On	Off
43	53	On	Off	On	Off	On	On
44	54	On	Off	On	On	Off	Off
45	55	On	Off	On	On	Off	On
46	56	On	Off	On	On	On	Off
47	57	On	Off	On	On	On	On
48	60	On	On	Off	Off	Off	Off
49	61	On	On	Off	Off	Off	On
50	62	On	On	Off	Off	On	Off
51	63	On	On	Off	Off	On	On
52	64	On	On	Off	On	Off	Off
53	65	On	On	Off	On	Off	On
54	66	On	On	Off	On	On	Off
55	67	On	On	Off	On	On	On
56	70	On	On	On	Off	Off	Off
57	71	On	On	On	Off	Off	On
58	72	On	On	On	Off	On	Off
59	73	On	On	On	Off	On	On
60	74	On	On	On	On	Off	Off
61	75	On	On	On	On	Off	On
62	76	On	On	On	On	On	Off
63	77	On	On	On	On	On	On

Spare Allen-Bradley Parts

## Switch SW2

Switch SW2 is used to select:

- Baud rate
- Parity
- Number of Stop Bits
- Point-to-Point or Multi-Drop
- Checksum mode (CRC or BCC)



AB0399A

**Table 3.C**  
**Switch SW2 Settings for BCC/CRC Selection**

SW2-8	Function
Off	BCC Checksum
On	CRC Checksum

**Table 3.D**  
**Switch SW2 Settings for Point-to-Point / Multi-Drop Selection**

SW2-7	Function
Off	Point-to-Point
On	Multi-Drop

**Table 3.E**  
**Switch SW2 Settings for Number of Stop Bits**

SW2-6	Function
Off	1 Stop Bit
On	2 Stop Bits

**Table 3.F**  
**Switch SW2 Settings for Parity Selection**

SW2-5	SW2-4	Function
Don't Care	Off	Parity Disabled
Off	On	Even Parity
On	On	Odd Parity

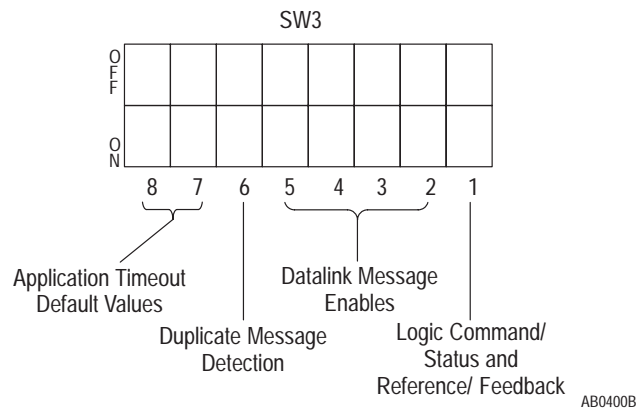
**Table 3.G**  
**Switch SW2 Settings for Baud Rate**

Switch Value (Decimal)	SW2-3	SW2-2	SW2-1	Baud Rate
0	Off	Off	Off	110
1	Off	Off	On	300
2	Off	On	Off	600
3	Off	On	On	1200
4	On	Off	Off	2400
5	On	Off	On	4800
6	On	On	Off	9600
7	On	On	On	19200

### Switch SW3

Switch SW3 is used to select:

- Logic Command/Status and Reference/Feedback
- DataLinks (up to four DataLinks)
- Stop Bits (1 or 2)
- Application Timeout Default Value



**Table 3.H**  
Switch SW3 Settings for Logic Command/Status and Reference/Feedback

SW3-1	Function
Off	Disable Logic Command/Status and Reference/Feedback messaging
On	Enable Logic Command/Status and Reference/Feedback messaging

**Table 3.I**  
Switch SW3 Settings for Datalink A

SW3-2	Function
Off	Disable Datalink A messaging
On	Enable Datalink A messaging

**Table 3.J**  
Switch SW3 Settings for Datalink B

SW3-3	Function
Off	Disable Datalink B messaging
On	Enable Datalink B messaging

**Table 3.K**  
Switch SW3 Settings for Datalink C

SW3-4	Function
Off	Disable Datalink C messaging
On	Enable Datalink C messaging



**Table 3.L**  
**Switch SW3 Settings for Datalink D**

SW3-5	Function
Off	Disable Datalink D Messaging
On	Enable Datalink D Messaging

**Table 3.M**  
**Switch SW3 Settings for Duplicate Message Detection**

SW3-6	Duplicate Message Detection
Off	Disable Duplicate Message Detection
On	Enable Duplicate Message Detection

**Table 3.N**  
**Switch SW3 Settings for Application Timeout Default Value**

SW3-8	SW3-7	Application Timeout Value
Off	Off	No Timeout (Disabled)
Off	On	1 Second
On	Off	30 Seconds
On	On	60 Seconds

**NOTE:** The Application Timeout defaults to the value set by switches SW3-7 and -8. The default value is used for Application Timeout unless the user writes a value to the Application Timeout address in the Communications Module Data Table. If power is removed the default value is reloaded upon powerup.

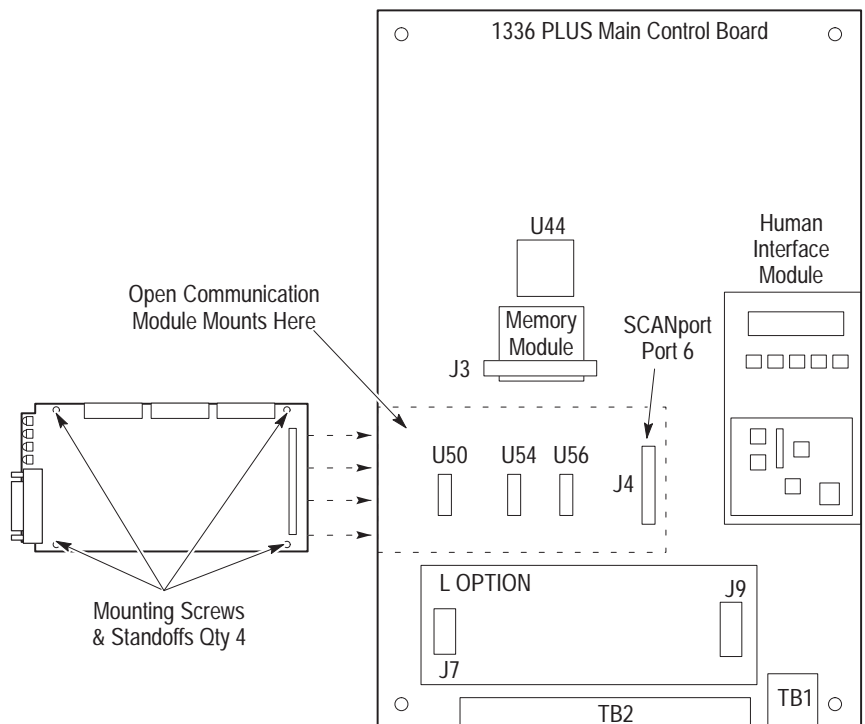
## Mounting the Communications Module

The Communications Module can be provided in three mounting configurations:

- Open style board, factory installed in a drive (not available for all drives)
- Open style board as a separate kit
- Enclosed style for panel mount or DIN rail mount

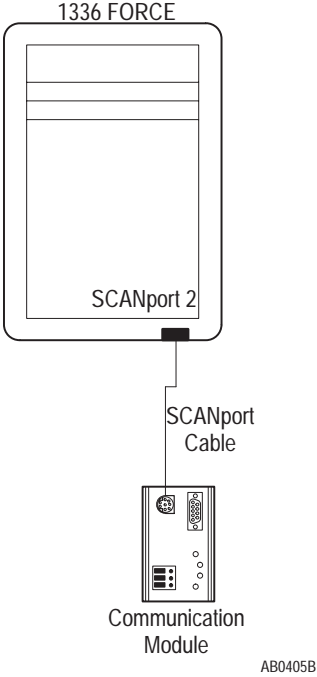
This section provides mounting information for the Enclosed style and the Open style kit.

**Figure 3.1**  
**Open Style Communications Module Mounting Location (1336 PLUS 7.5–500HP)**



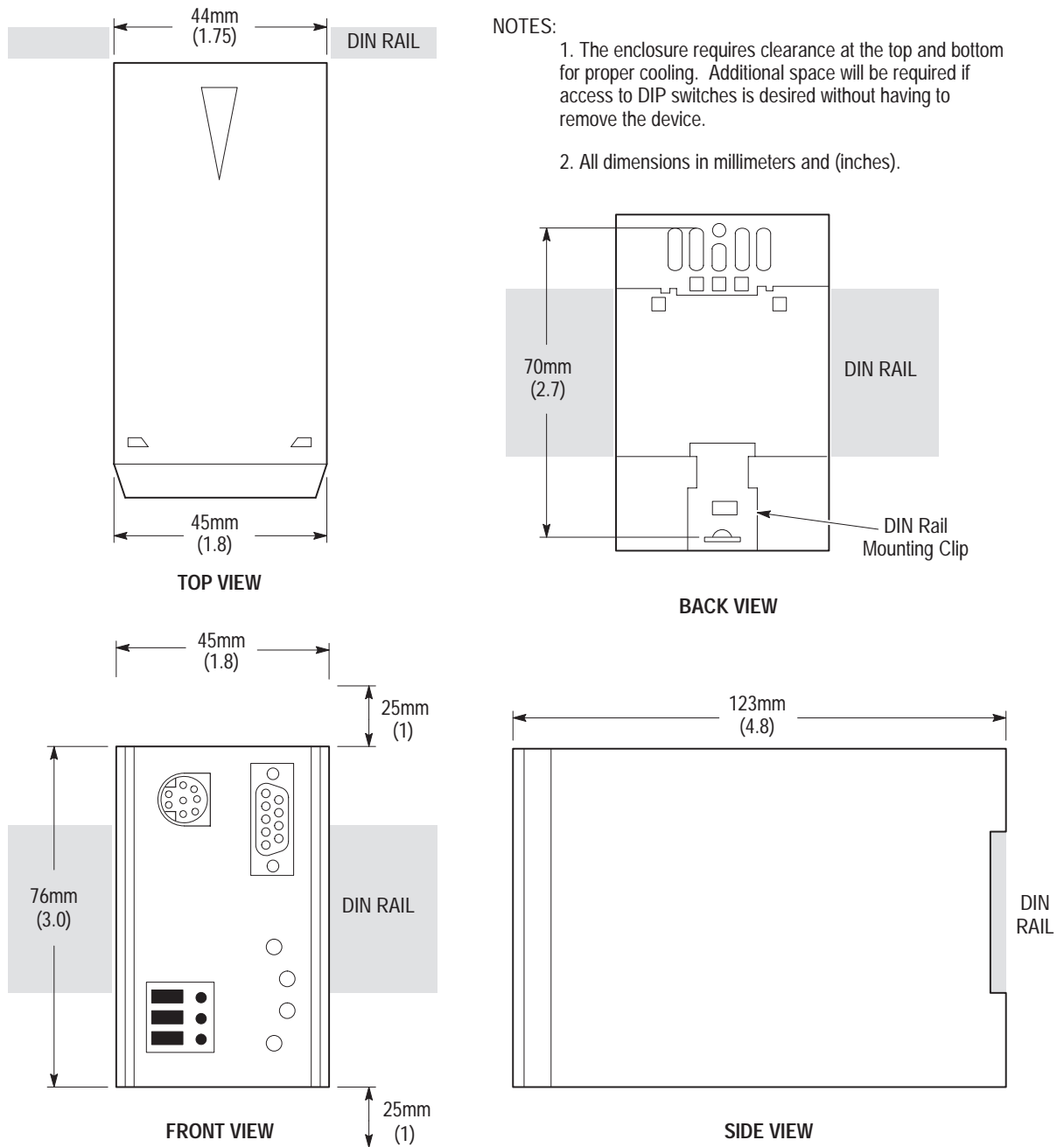
AB0404C

Figure 3.2  
Enclosed Style Communications Module Mounting Location  
(1336 FORCE and 1336 PLUS Drives)



## Enclosed Style Communications Module Dimensions

**Figure 3.3**  
**Enclosed Style Communications Module Dimensions**

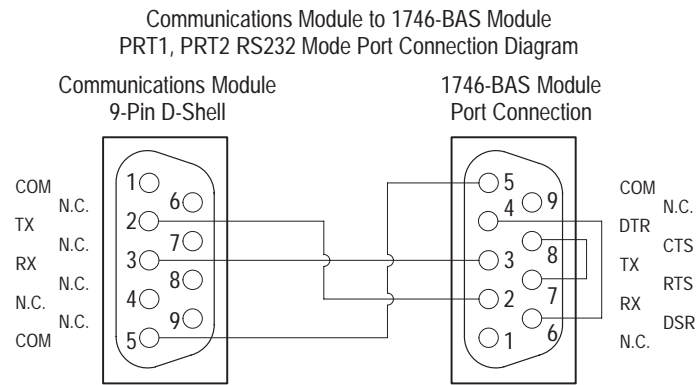


AB0406A

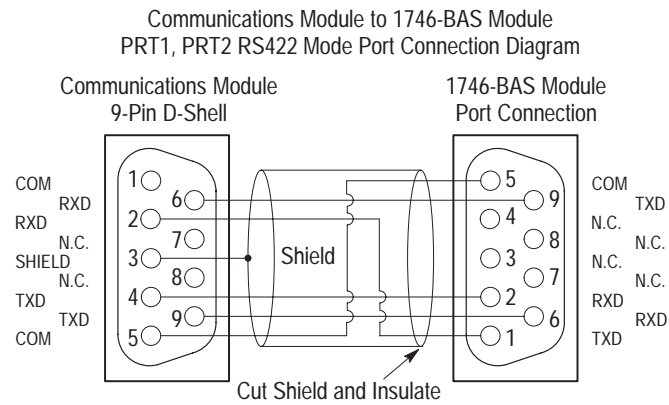
Cable Connections

RS485/RS422/RS232 Connection Examples

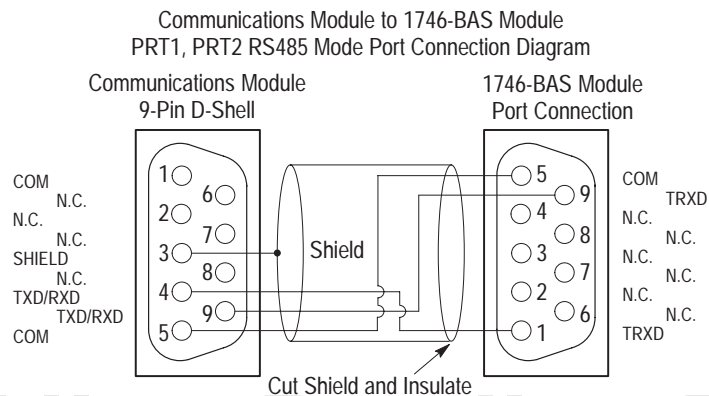
Figure 3.4  
1746-BAS Module Serial Connections



AB0401B

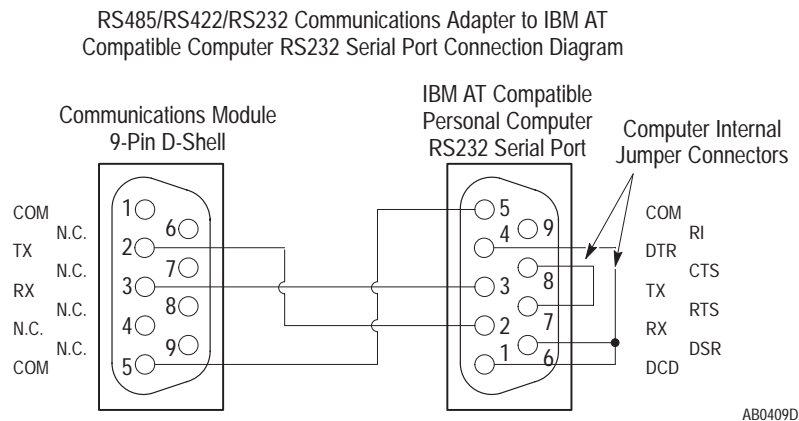


AB0402B

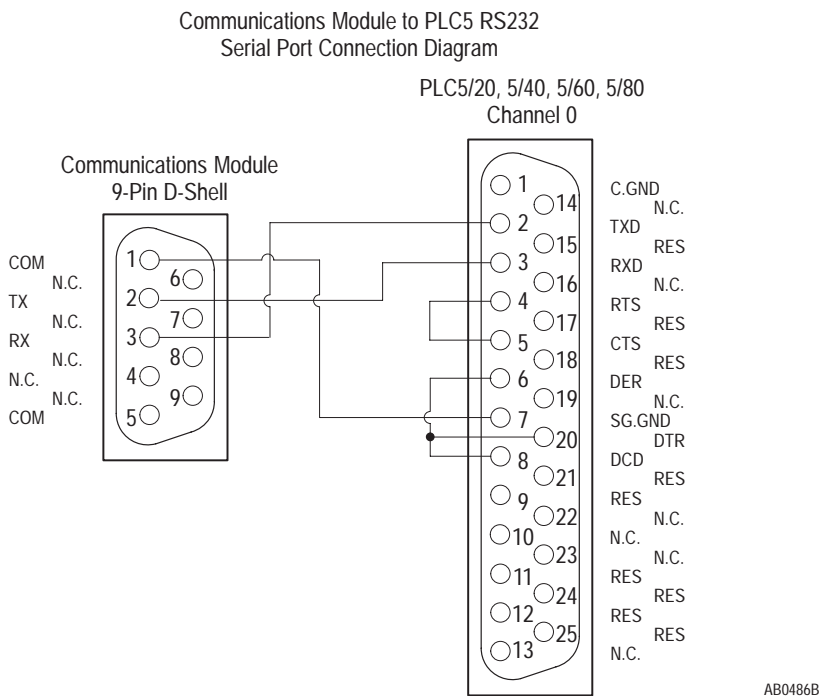


AB0403B

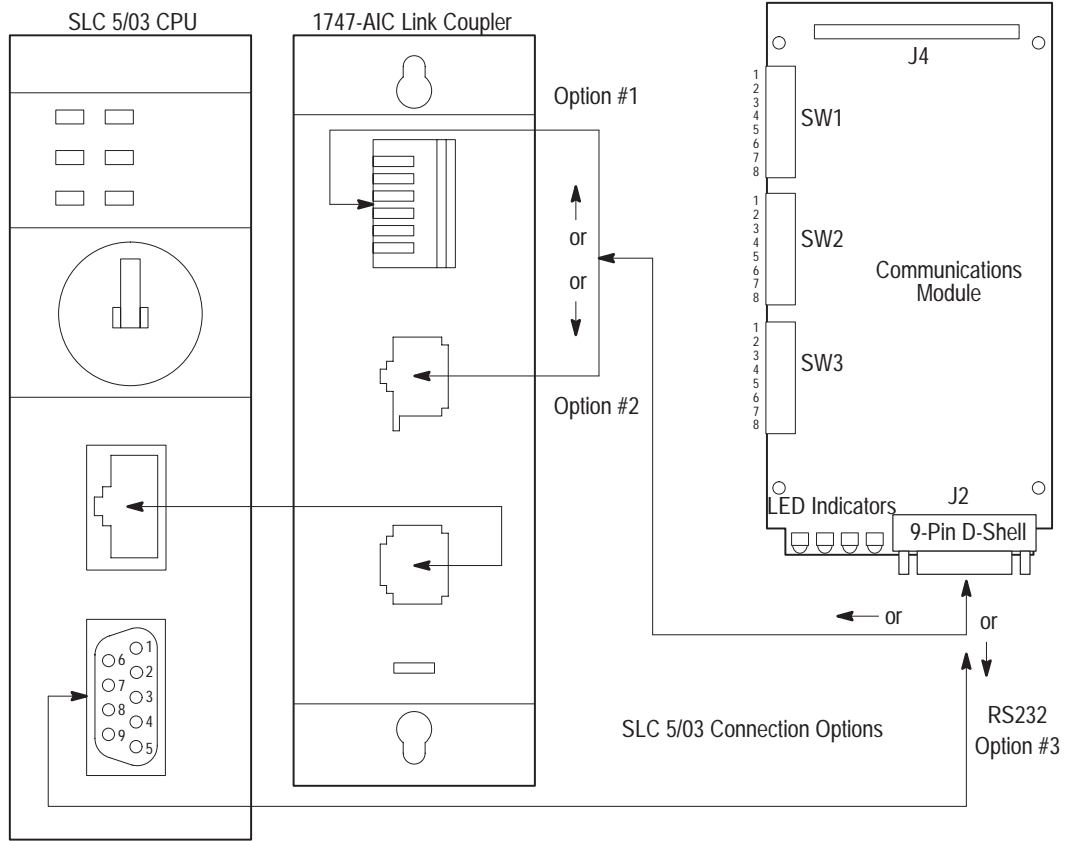
**Figure 3.5**  
**IBM PC Compatible Serial Connections**



**Figure 3.6**  
**PLC5 Channel 0 Serial Connections**

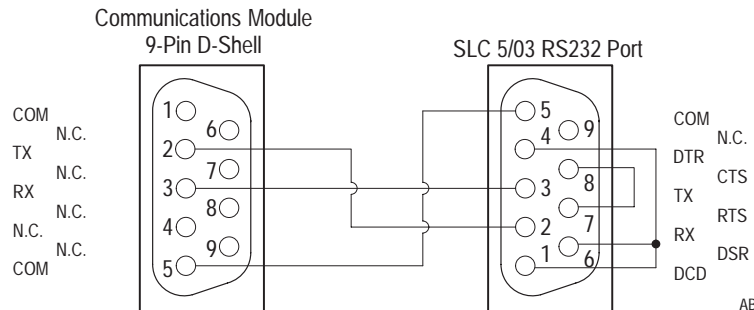


**Figure 3.7**  
SLC 5/03 Serial Connection Options



AB0412C

**Figure 3.8**  
SLC 5/03 Cable Option #3  
RS232 using DF1 Protocol



AB0411B

## SCANport Link Connection

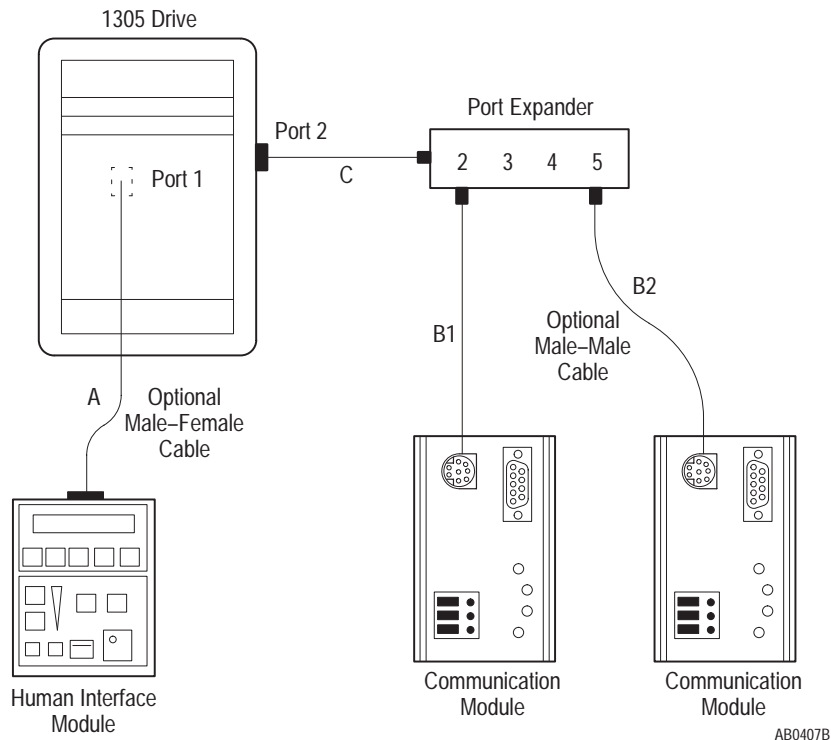
### Cable Requirements

SCANport cables are available in either Male to Male or Male to Female configuration. Cables of up to 10 meters (33 feet) can be connected from the master to the SCANport device (A in Figure 3.9). If a Port Expander is used as shown in Figure 3.9, the cable length from the master to the Port Expander must be subtracted from the cable length used to connect the device to the expander ( $B1 + C = \text{max } 10 \text{ meters}$ ).

### 1305 Drive

An Allen-Bradley SCANport link cable is used to make the connection between the Communications Module and the drive (Figure 3.9).

**Figure 3.9**  
**SCANport Connection on Communications Module**



**IMPORTANT:** The maximum cable distance between any two devices cannot exceed 10 meters (33 feet) of cable.

For example:  $A + B1 + C \leq 10 \text{ meters}$   
 $A + B2 + C \leq 10 \text{ meters}$   
 $B1 + B2 \leq 10 \text{ meters}$



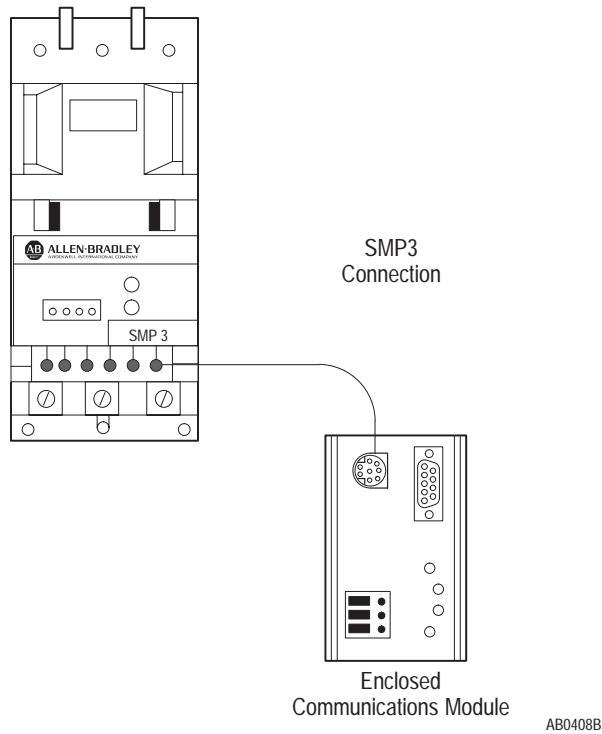
### 1336 PLUS and 1336 FORCE

Refer to the product manual for connection information. On larger horsepower 1336 PLUS and FORCE drives with an open Communications Module mounted in the drive, no separate SCANport cable connection is required.

### SMP 3

An Allen-Bradley SCANport cable is used to make the connection between the Communications Module and an SMP3.

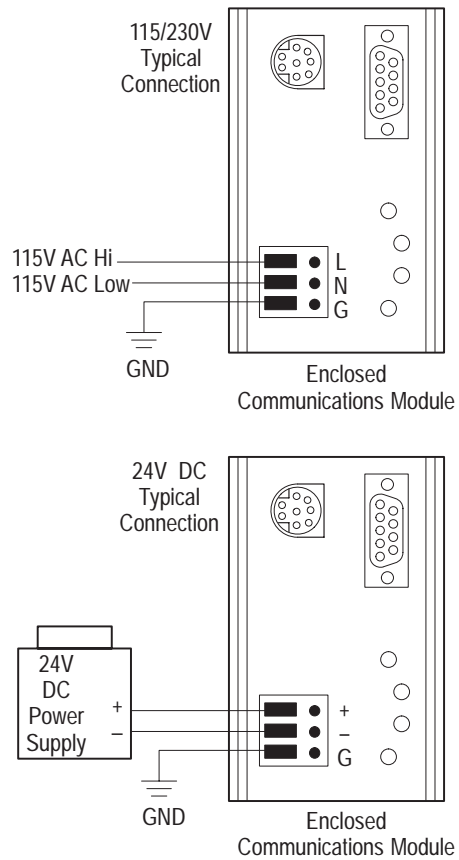
Figure 3.10  
SCANport Connection on Communications Module



## Power Supply Connections

The Enclosed Communications Module is powered from a separate 24V DC or 115V AC power supply (Figure 3.11). With the Open style Communications Module board mounted in the drive, no separate power supply connections are required.

**Figure 3.11**  
Typical Power Supply Connection



AB0413B

## SCANport Datalink Operation

### Chapter Objectives

In this chapter, you will read about:

- Configuring the SCANport device Datalinks.
- Datalink Operation.

### SCANport Datalinks

A Datalink is a type of pointer used by some SCANport devices to transfer information to the drive. Datalinks allow parameter values to be written when the Logic Command and Reference are sent to the drive. Datalinks also allow parameter values to be read whenever the Logic Status and Feedback are read.

SCANport devices that support this function have a group of parameters for Datalink configuration. These parameters are identified as “Datalink In” and “Datalink Out” parameters. The Datalink functions are enabled by setting the correct switch to “Enable” on SW3 of the Communications Module and configuring the “Datalink In” and “Datalink Out” parameters in the SCANport device.

Each Datalink consists of two 16-bit words of input and two 16-bit words of output. Each of the two input words can be configured to write to a different destination parameter inside the SCANport device by setting the two “Datalink In” parameters for that Datalink to the desired destination parameters. Similarly, each of the two output words is configured by setting the two “Datalink Out” parameters for that Datalink.

Each Datalink switch on SW3 can enable or disable one Datalink. If a Datalink is enabled the value of the parameters set into the “Datalink Out” parameters will be transferred to the Communications Module and the data sent by the Communications Module for the Datalink will be transferred into the parameters set into the “Datalink In” parameters. If a Datalink is not enabled the data transferred to the SCANport device for that Datalink will be zero and any data sent by the SCANport device will be ignored by the Communications Module.

If no “Datalink In” parameter is configured for an input word that word will be ignored. If no “Datalink Out” parameter is configured for an output word the output word will be undefined (usually set to zero).

**This Page Intentionally Left Blank.**

## Configuration and Interfacing

### Chapter Objectives

The purpose of this chapter is to provide you with information on how the Communications Module communicates with a serial device. The following topics will be explained:

- Communications Module data table structure
- Data transfer through the Communications Module
- Block transfer emulation



**ATTENTION:** It is recommended that when a system is configured for the first time, that the motor be disconnected from the machine or process during initial testing.

---

### Basic Operation

#### Communications Module Data Table Structure and Supported PCCC Command List

The Communications Module maintains a data table that allows the module to communicate with serial devices using standard PCCC commands. The PCCC commands supported by the Communications Module are listed in Table 5.A and the structure of the data table is documented in Table 5.B.

**Table 5.A**  
**PCCC Commands Supported by the Communications Module**

CMD Code	FNC Code	Command Name	PLC Addressing Method
01h	n/a	Unprotected Read	PLC-2 Address
06h	00h	Echo	n/a
	01h	Read Diagnostic Counters	Variable (modified PLC-2 addresses)
	02h	Set Variables (#ENQs, #NAKs, TIMEOUT)	n/a
	03h	Identify Host and Some Status	n/a
	04h	Set Timeout	n/a
	05h	Set #NAKs	n/a
	06h	Set #ENQs	n/a
	07h	Reset Diagnostic Counters	n/a
	09h	Read Link Parameters	Logical Address
	0Ah	Set Link Parameters	Logical Address
08h	n/a	Unprotected Write	PLC-2 Address
0Fh	67h	Typed Write	System Address (4 possibilities)
	68h	Typed Read	System Address (4 possibilities)
	A2h	Protected Typed Logical Read	File#/Type/Element#/Sub-element#
	AAh	Protected Typed Logical Write	File#/Type/Element#/Sub-element#

**Table 5.B**  
**Data Table Structure for PLC-5 Style Addressing**

Parameter Number	PLC-5 Style Address	Description of Location's Purpose
1 – 999	N10:1 – 999	Parameter Value Read or Write
1000 – 1999	N11:0 – 999	
—	—	
8000 – 8999	N18:0 – 999	
9000 – 9999	N19:0 – 999	
	N20:0 – 127	Status of Last Parameter Write
1 – 999	N30:1 – 999	Parameter Read Full
1000 – 1999	N31:0 – 999	
—	—	
8000 – 8999	N38:0 – 999	
9000 – 9999	N39:0 – 999	
	N40:0 – 63	Block Transfer Emulation Area
	N41:0	Logic Command/Status
	N41:1	Reference/Feedback
	N41:2	Datalink A1
	N41:3	Datalink A2
	N41:4	Datalink B1
	N41:5	Datalink B2
	N41:6	Datalink C1
	N41:7	Datalink C2
	N41:8	Datalink D1
	N41:9	Datalink D2
	N42:0	#ENQs
	N42:1	#NAKs
	N42:2	Message TIMEOUT (mS)
	N42:3	Application TIMEOUT (Seconds)
	System File 0 (or N200:1 – 63)	System Area

**NOTE:** The address locations shown in this table are not limited to PLC-5 commands and may be used by any device capable of generating them.

**Table 5.C**  
**Data Table Structure for PLC-2 Style Addressing**

Parameter Number	PLC-2 Style Address Decimal (Octal)	Description of Location's Purpose
1 – 7039	512 + Parm # (1001 to 16577)	Parameter Value Read
	(16600 to 16777)	Status of Last Parameter Write
1 – 7039	7680 + Parm # (17001 to 34577)	Parameter Read Full
	(34600 to 34677)	Block Transfer Emulation Area
	(34700)	Logic Command/Status
	(34701)	Reference/Feedback
	(34702)	Datalink A1
	(34703)	Datalink A2
	(34704)	Datalink B1
	(34705)	Datalink B2
	(34706)	Datalink C1
	(34707)	Datalink C2
	(34710)	Datalink D1
	(34711)	Datalink D2
	(34712)	#ENQs
	(34713)	#NAKs
	(34714)	Message TIMEOUT (mS)
	(34715)	Application TIMEOUT (Seconds)
		(34716 to 37677)
	(37700 to 37777)	System Area

**NOTE:** The address locations shown in this table are not limited to PLC-2 commands and may be used by any device capable of generating them.



**Table 5.D**  
**Data Table Structure for SLC-500 Style Addressing**

Parameter Number	SLC-500 Style Address	Description of Location's Purpose
1 – 249	N50:1 – 249	Parameter Value Read or Write
250 – 499	N51:0 – 249	
500 – 749	N52:0 – 249	
—	—	
9250 – 9499	N87:0 – 249	
9500 – 9749	N88:0 – 249	
9750 – 9999	N89:0 – 249	
	N20:0 – 127	Status of Last Parameter Write
1 – 249	N90:1 – 249	Parameter Read Full
250 – 499	N91:0 – 249	
500 – 749	N92:0 – 249	
—	—	
9250 – 9499	N127:0 – 249	
9500 – 9749	N128:0 – 249	
9750 – 9999	N129:0 – 249	
	N40:0 – 63	Block Transfer Emulation Area
	N41:0	Logic Command/Status
	N41:1	Reference/Feedback
	N41:2	Datalink A1
	N41:3	Datalink A2
	N41:4	Datalink B1
	N41:5	Datalink B2
	N41:6	Datalink C1
	N41:7	Datalink C2
	N41:8	Datalink D1
	N41:9	Datalink D2
	N42:0	#ENQs
	N42:1	#NAKs
	N42:2	Message TIMEOUT (mS)
	N42:3	Application TIMEOUT (Seconds)
	or N200:0 – 63	System Area

**NOTE:** The address locations shown in this table are not limited to SLC commands and may be used by any device capable of generating them.

The data tables have up to eight areas, each having a different purpose.

1. **Parameter Value Read or Write.** Reading data from files in this area will cause the Communications Module to read parameter values from the SCANport device and send those values as the response to the read message. Writing data to files in this area will cause the Communications Module to write that data into SCANport device parameters.
2. **Status of Last Parameter Write.** This area is read-only. When read, the data returned will contain status information from the last parameter write that was performed by the Communications Module. If no errors occurred during the write, all of the data returned will be zeros. Read this area beginning at element number zero.
3. **Parameter Read Full.** This area is read-only. When read, the data returned consists of 20 words (40 bytes) of information about each parameter including scaling, parameter text, units text, minimum, maximum and default values. When reading this area, set the number of elements to twenty times the number of parameters to be read.
4. **Block Transfer Emulation Area.** This area provides a method for sending and receiving SCANport messages to and from the SCANport device. This allows the user to perform every SCANport command supported by the device. The structure of this data table is identical to that of a block transfer data table for the 1203-GD1, GK1, GM1 RIO Communications Module.

To send a SCANport message, write data into this area beginning with element number zero. Allow sufficient time for the SCANport device to respond to the message and then read the response message from this area beginning with element number zero.

5. **Producer/Consumer Emulation Area.** Each element in this area has a different function. Refer to the DIP switch configuration tables in Chapter 3 for more information.
  - Logic Command/Status. Writing sends a Logic Command to the drive. Reading supplies the SCANport device Logic Status. Refer to the manual supplied with the SCANport device for more information.
  - Reference/Feedback. Writing sends a reference to the SCANport device. Reading supplies feedback from the SCANport device. The meaning of the reference and feedback values are dependent upon the type of SCANport device.
  - Datalink A1. Writing to Datalink A1 sends a value to the parameter pointed to by the DataIn A1 parameter of the SCANport device. Reading from Datalink A1 reads the value of the parameter pointed to by the DataOut A1 parameter of the SCANport device.
  - Datalink A2 through Datalink D2 function the same as Datalink A1.

6. **Communications Module Parameters.** Each of the four elements in this area can be read or written and affects the operation of the Communications Module as follows:
  - Number of ENQ's. The number of ENQ's sent by the module before giving up on receiving ACK or NAK. (Default = 3)
  - Number of NAK's. The number of times the module will resend a message if the response is always NAK. (Default = 3)
  - Message Timeout. The number of milliseconds the module will wait before sending an ENQ. (Default = 100mS)
  - Application Timeout. The number of seconds the module will wait between messages before faulting the SCANport device it is connected to. (Default is set by configuration DIP switches.)
7. **Reserved for Future Expansion.** If a read or write to any address in this area is attempted the Communications Module will respond with an error message.
8. **System Area.** Performing a read from this area will cause the Communications module to respond with a 22-character string. This string is set at power-up to contain the Product Text String from the SCANport device with "/1203" appended to it. Writing to this area will change the characters contained in the string. Cycling power will return the string to its original text.

## Configuration Examples

### DF1 Messaging with a PLC-5/80 Example (Read Parameters 1 through 50)

Ladder rung example for Gx2 manual

Rung 2:0

```

| I:000 MG20:0   B3                               +MSG-----+      |
+---] [---]/[---[ONS]-----+SEND/RECEIVE MESSAGE  +- (EN)-+
|   00   EN     2                               |Control block  MG20:0+- (DN) |
|                                                |                               +- (ER) |
|                                                +-----+      |

```

Data Table Report

MESSAGE INSTRUCTION DATA MONITOR FOR CONTROL BLOCK MG20:0

```

Communication Command:      PLC-5 TYPED READ
PLC-5 Data Table Address:   N30:0          ignore if timed-out:    0 TO
Size in Elements:          50              to be retried:         0 NR
Local/Remote:              LOCAL          awaiting execution:     0 EW
  Remote Station:          N/A            continuous:           0 CO
  Link ID:                 N/A            error:                 0 ER
  Remote Link Type:        N/A            message done:         0 DN
Local Node Address:         001            message transmitting:  0 ST
Destination Data Table Address: N10:1      message enabled:       0 EN
Port Number:                00

```

Error Code: 0000 (HEX)

**Notes:**

1. I:000/00 is any application related conditioning logic.
2. MG20:0.EN is the “enabled” status bit from the message block.
3. B3/2 is a one-shot and causes the message to be resent each time the message block completes or errors (as long as I:000/00 is true).
4. The DF1 address of the PLC-5 is the same as its DH+ address (set by dip switch SW1 on the PLC-5).
5. Refer to Publication 6200–6.4.11, Instruction Set Reference, for information on the MSG block.
6. Refer to Publication 1785–6.6.1, Hardware Installation Manual, for information on configuring the PLC-5 Channel 0 hardware.
7. Refer to Publication 6200–6.4.6, Software Configuration and Maintenance, for information on configuring the PLC-5 Channel 0 driver.
8. Only one message may be active to a Communications Module at any time. This requirement must be ensured by the PLC program written by the user.

## DF1 Messaging with a 1746-BAS Module Example

(Write 10 Parameters then read 10 parameters)

```
10  REM -----
20  REM
30  REM This file is a program for the 1746-BAS module.
40  REM
50  REM It performs a PLC2 Unprotected Write (08) followed by
60  REM a PLC2 Unprotected Read (01) over the DF1 link on port #2
70  REM
80  REM -----
90  STOP
100 STRING 0,0
110 STRING 512,127
120 $(1)="THIS IS A TEST! "
130 REM
140 REM -----
150 REM Setup port 1 to 9600 baud, no parity, 8 bits, 1 stop bit,
160 REM software handshaking, and battery backed ram data storage.
170 REM      !!!!REMEMBER TO SET TERMINAL TO MATCH!!!!
180 REM -----
190 MODE (PRT1,9600,N,8,1,S,R)
200 REM -----
210 REM
220 REM Setup port 2 to 300 baud, no parity, 8 bits, 1 stop bit,
230 REM software handshaking, and battery backed ram data storage.
240 REM
250 REM -----
260 MODE (PRT2,300,N,8,1,S,R)
270 REM -----
280 REM
290 REM Enable DF1 driver
300 REM (20 = Setup for Full Duplex, Auto-Detect Embedded Responses,
310 REM      Disable Duplicate Packet Detection, BCC error checking)
320 REM (200 = Wait 1 second for polling by Master)
330 REM (2 = 2 retries)
340 REM (0= No RTS on delay)
350 REM (0 = No RTS off delay)
360 REM (8 = 1746-BAS module address)
370 REM -----
380 PUSH 20
390 PUSH 200
400 PUSH 2
410 PUSH 0
420 PUSH 0
430 PUSH 8
440 CALL 108
450 REM DF1 PLC REMOTE WRITE COMMAND
460 PUSH 2 : REM PLC2 Unprotected Write
470 PUSH 1 : REM Communications Module Node Address
480 PUSH 11 : REM File Number (ignored in this example)
490 PUSH ASC(N) : REM Communications Module File Type
500 PUSH 623 : REM Starting Word in File
510 PUSH 10 : REM Number of Words to Transfer
520 PUSH 50 : REM Command Time-out (x100ms)
```

```
530 PUSH 2 : REM Data Source (2 = Internal String)
540 PUSH 0 : REM Offset in M0 file (Not used in this example)
550 PUSH 1 : REM Internal String Number
560 CALL 123
570 POP S
580 IF (S<>0) THEN PRINT "Unsuccessful PLC2 Unprotected Write"
590 PUSH 123
600 CALL 29
610 REM DF1 PLC REMOTE READ COMMAND
620 PUSH 2 : REM PLC2 Unprotected Read
630 PUSH 1 : REM Communications Module Node Address
640 PUSH 10 : REM File Number (ignored in this example)
650 PUSH ASC(N) : REM Communications Module File Type
660 PUSH 623 : REM Starting Word in File
670 PUSH 10 : REM Number of Words to Transfer
680 PUSH 50 : REM Command Time-out (x100ms)
690 PUSH 2 : REM Data Source (2 = Internal String)
700 PUSH 0 : REM Offset in M0 file (Not used in this example)
710 PUSH 1 : REM Internal String Number
720 CALL 122
730 POP S
740 IF (S<>0) THEN PRINT "Unsuccessful PLC2 Unprotected Read"
750 PUSH 122
760 CALL 29
```

**This Page Intentionally Left Blank.**

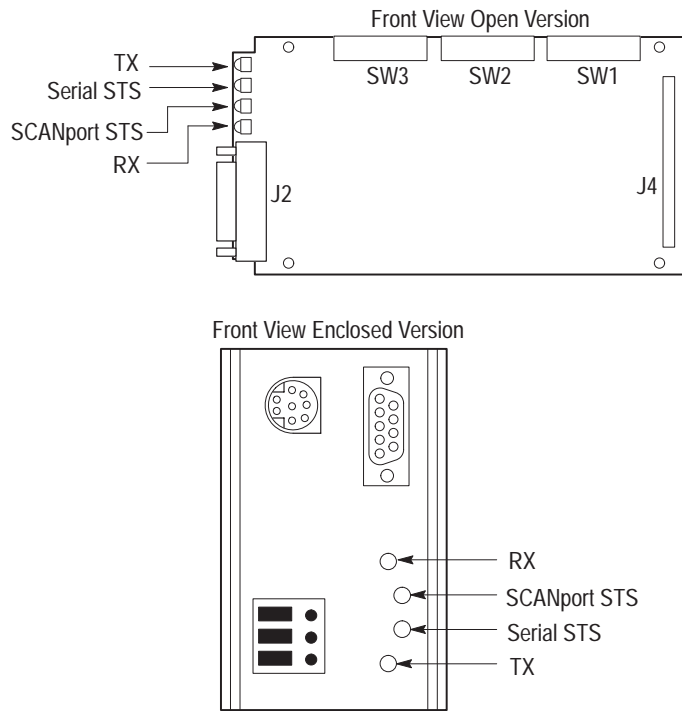


## Troubleshooting

### Chapter Objectives

Use this chapter to help you troubleshoot your Serial Communications system using the LED indicators on the front of the device (Figure 6.1). The Communications Module is a non-serviceable device that should be returned to Allen-Bradley for replacement when a major fault exists that is attributable to the Communications Module itself.

**Figure 6.1**  
LED Locations



**ATTENTION:** Servicing energized industrial control equipment can be hazardous. Electrical shock, burns, or unintentional actuation of controlled industrial equipment may cause death or serious injury. Follow the safety-related practices of NFPA 70E, Electrical Safety for Employee Workplaces, when working on or near energized equipment. Do not work alone on energized equipment.



**ATTENTION:** Do not attempt to defeat or override fault circuits. The cause of a fault indication must be determined and corrected before attempting operation. Failure to correct a drive or system malfunction may result in personal injury and/or equipment damage due to uncontrolled machine system operation.

**Table 6.A**  
**LED Troubleshooting Table**

Indicator	Color	Description	Recommended Action
Serial Sts	Green (Blinking)	Link OK, off-line	Check configuration switch settings, check for serial cable connection, cycle Communications Module power
	Green (Steady)	Link OK, on-line	None, system functioning properly
	Red (Steady)	Faulted	Check configuration switch settings, check for serial cable connection, cycle power, replace module
SCANport Sts	Green (Blinking)	Link OK, not connected	Check configuration switch settings, check for serial cable connection, cycle power
	Green (Steady)	Link OK, connected	None
	Red (Steady)	Faulted	Check configuration switch settings, check for serial cable connection, cycle power, replace module
TX	Off	No transmission occurring	Send serial data again
	Amber	Transmission occurring	None
RX	Off	No transmission received	Check data device to verify it is sending data
	Amber	Transmission being received	None

## Specifications

### Chapter Objectives

The purpose of this chapter is to provide you with background information and specifications that may be necessary when installing or applying your Communications Module.

### Product Specifications

	Open Style	Enclosed Style 115/230V AC	Enclosed Style 24V DC
<b>Catalog Number:</b>	-GM2	-GD2	-GK2
<b>Environmental:</b>			
Operating Temperature	0 to 50°C (32 to 122°F)	0 to 50°C (32 to 122°F)	0 to 50°C (32 to 122°F)
Storage Temperature	-40 to 85°C (-40 to 185°F)	-40 to 85°C (-40 to 185°F)	-40 to 85°C (-40 to 185°F)
Relative Humidity	0 to 95%, Non-condensing	0 to 95%, Non-condensing	0 to 95%, Non-condensing
<b>Electrical:</b>			
Input Voltage	Supplied by drive	85 to 264V AC, 1-phase	24V DC, +/- 10%
Input Frequency	NA	45 to 63 Hz	NA
Input Current	NA	35mA maximum	0.4 amps maximum
SCANport Load	60mA DC	60mA DC	60mA DC
<b>Communications:</b>			
SCANport Side	SCANport Peripheral Interface	SCANport Peripheral Interface	SCANport Peripheral Interface
Serial Side	RS-232/RS422/RS485 (DF1)	RS232/RS422/RS485 (DF1)	RS232/RS422/RS485 (DF1)
Baud Rates	110, 300, 600, 1200, 2400, 4800, 9600, 19.2K	110, 300, 600, 1200, 2400, 4800, 9600, 19.2K	110, 300, 600, 1200, 2400, 4800, 9600, 19.2K
Checksum	BCC or CRC	BCC or CRC	BCC or CRC
<b>Dimensions:</b>			
	Open (IP00)	NEMA Type 1 (IP30)	NEMA Type 1 (IP30)
	NA	45w x 76h x 123d mm (1.8 x 3.0 x 4.8 in.)	45w x 76h x 123d mm (1.8 x 3.0 x 4.8 in.)

### Module Compatibility

This module is intended for use with devices that communicate via RS232, RS422, or RS485 hardware standards using the DF1 protocol. It is intended to provide a means for transmitting messages between these serial-communications devices and Allen-Bradley SCANport devices.

**This Page Intentionally Left Blank.**

# Spare Allen-Bradley Parts



# Spare Allen-Bradley Parts





# Spare Allen-Bradley Parts



# Spare Allen-Bradley Parts



# Spare Allen-Bradley Parts





# We Want Our Manuals to be the Best!

You can help! Our manuals must meet the needs of you, the user. This is your opportunity to make sure they do just that. By filling out this form you can help us provide the most useful, thorough, and accurate manuals available. Please take a few minutes to tell us what you think. Then mail this form, FAX it, or send comments via E-Mail.

FAX: to your local Allen-Bradley Sales Office or 414/512-8579

E-Mail: via Internet to "SEPATTERSON@ra.rockwell.com"

PUBLICATION NAME \_\_\_\_\_

PUBLICATION NUMBER, DATE AND PART NUMBER (IF PRESENT) \_\_\_\_\_

✓ **CHECK THE FUNCTION THAT MOST CLEARLY DESCRIBES YOUR JOB.**

- SUGGEST / RESPONSIBLE FOR THE PURCHASE OF EQUIPMENT
- MAINTAIN / OPERATE PROGRAMMABLE MACHINERY
- DESIGN / IMPLEMENT ELECTRICAL SYSTEMS
- TRAIN/EDUCATE MACHINE USERS
- SUPERVISE FLOOR OPERATIONS

✓ **WHAT LEVEL OF EXPERIENCE DO YOU HAVE WITH EACH OF THE FOLLOWING PRODUCTS?**

	NONE	LITTLE	MODERATE	EXTENSIVE
PROGRAMMABLE CONTROL	<input type="checkbox"/>	<input type="checkbox"/>	<input type="checkbox"/>	<input type="checkbox"/>
AC / DC DRIVES	<input type="checkbox"/>	<input type="checkbox"/>	<input type="checkbox"/>	<input type="checkbox"/>
PERSONAL COMPUTERS	<input type="checkbox"/>	<input type="checkbox"/>	<input type="checkbox"/>	<input type="checkbox"/>
NC / CNC CONTROLS	<input type="checkbox"/>	<input type="checkbox"/>	<input type="checkbox"/>	<input type="checkbox"/>
DATA COMMUNICATIONS / LAN	<input type="checkbox"/>	<input type="checkbox"/>	<input type="checkbox"/>	<input type="checkbox"/>

✓ **RATE THE OVERALL QUALITY OF THIS MANUAL BY CIRCLING YOUR RESPONSE BELOW. (1) = POOR (5) = EXCELLENT**

HELPFULNESS OF INDEX / TABLE OF CONTENTS		1	2	3	4	5
CLARITY		1	2	3	4	5
EASE OF USE		1	2	3	4	5
ACCURACY AND COMPLETENESS		1	2	3	4	5
QUALITY COMPARED TO OTHER COMPANIES' MANUALS		1	2	3	4	5
QUALITY COMPARED TO OTHER ALLEN-BRADLEY MANUALS		1	2	3	4	5

✓ **WHAT DID YOU LIKE MOST ABOUT THIS MANUAL?**

✓ **WHAT DID YOU LIKE LEAST ABOUT THIS MANUAL?**

✓ **PLEASE LIST ANY ERRORS YOU FOUND IN THIS MANUAL (REFERENCE PAGE, TABLE, OR FIGURE NUMBERS).**

✓ **DO YOU HAVE ANY ADDITIONAL COMMENTS?**

✓ **COMPLETE THE FOLLOWING.**

NAME \_\_\_\_\_ COMPANY \_\_\_\_\_

TITLE \_\_\_\_\_ DEPARTMENT \_\_\_\_\_

STREET \_\_\_\_\_ CITY \_\_\_\_\_ STATE \_\_\_\_\_ ZIP \_\_\_\_\_

TELEPHONE \_\_\_\_\_ DATE \_\_\_\_\_

CUT ALONG DOTTED LINE 

Spare Allen-Bradley Parts

FOLD HERE

FOLD HERE



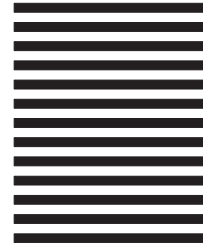
**BUSINESS REPLY MAIL**

FIRST CLASS PERMIT NO. 413 MEQUON, WI

POSTAGE WILL BE PAID BY ADDRESSEE

**ALLEN-BRADLEY**  
**Attn: Marketing Communications**  
**P.O. Box 760**  
Mequon, WI 53092-9907

NO POSTAGE  
NECESSARY  
IF MAILED  
IN THE  
UNITED STATES





# Index

## C

- Cable Connections, 3-13
- Cable Requirements, 3-16
- Communications Module
  - Basic Operation, 5-1
  - Compatibility, 7-1
  - Configuration Examples, 5-8
  - Configuration Switches, 2-5
  - Configurations, 2-1
  - Data Table Structure, 5-1
    - Definitions, 5-6
    - PLC-2 Style Addressing, 5-4
    - PLC-5 Style Addressing, 5-3
    - SLC-500 Style Addressing, 5-5
  - Device Compatibility, 2-2
  - Enclosed Style, 2-3
  - Enclosed Style Dimensions, 3-12
  - Mounting Configurations, 3-10
  - Open Style, 2-2
  - Product Description, 2-1
  - Product Specifications, 7-1
  - Setting Configuration Switches, 3-1
  - Supported PCCC Command List, 5-1
- Compatibility, 7-1
- Configuration Examples, 5-8
- Connection Examples
  - RS232, 3-13
  - RS422, 3-13
  - RS485, 3-13
- Connections
  - Cable, 3-13
  - Power Supply, 3-18
  - SCANport Link, 3-16

## D

- Datalink, Definition, 4-1
- DIP Switches, Description, 2-5

## F

- Factory Switch Settings, 3-2
- Firmware
  - Support, 1-1
  - Versions, 1-1

## L

- LED Locations, 6-1
- LED Troubleshooting Table, 6-2

## M

- Manual
  - Audience, 1-1
  - Objectives, 1-1
  - Organization, 1-2
- Module Configurations, Factory Switch Settings, 3-2
- Mounting Configurations, 3-10
  - Enclosed Style, 3-11
  - Open-Style, 3-10

## O

- Operation, Communications Module, 5-1

## P

- PLC-2 Style Addressing, Data Table Structure, 5-4
- PLC-5 Style Addressing, Data Table Structure, 5-3
- Power Supply Connections, 3-18

## S

- Safety Precautions, 1-2
- SCANport Datalinks, 4-1
- SCANport Link Connection, 3-16

Serial Device

- Compatibility, 1-3
- Configurations, 2-1

Setting Configuration Switches, 3-1

SLC-500 Style Addressing, Data Table Structure, 5-5

Special Terms, 1-1

Specifications, 7-1

Switch SW1 Settings

- Communications Mode, 3-3
- Functions, 3-3
- Serial Device Addressing, 3-4

Switch SW2 Settings

- Baud Rate, 3-7
- BCC Selection, 3-6
- CRC Selection, 3-6
- Functions, 3-6
- Multi-Drop Selection, 3-6
- Number of Stop Bits, 3-6

Parity Selection, 3-7

Point-to-Point Selection, 3-6

Switch SW3 Settings

Application Timeout Default Value, 3-9

Datalink A, 3-8

Datalink B, 3-8

Datalink C, 3-8

Datalink D, 3-9

Duplicate Message Detection, 3-9

Feedback, 3-8

Functions, 3-8

Logic Command, 3-8

Status and Reference, 3-8

## T

Troubleshooting

LED Locations, 6-1

LED Table, 6-2

SCANport is a trademark of Allen-Bradley Company, Inc.

# Spare Allen-Bradley Parts



Allen-Bradley, a Rockwell Automation Business, has been helping its customers improve productivity and quality for more than 90 years. We design, manufacture and support a broad range of automation products worldwide. They include logic processors, power and motion control devices, operator interfaces, sensors and a variety of software. Rockwell is one of the world's leading technology companies.



## Worldwide representation.

Argentina • Australia • Austria • Bahrain • Belgium • Brazil • Bulgaria • Canada • Chile • China, PRC • Colombia • Costa Rica • Croatia • Cyprus • Czech Republic • Denmark • Ecuador • Egypt • El Salvador • Finland • France • Germany • Greece • Guatemala • Honduras • Hong Kong • Hungary • Iceland • India • Indonesia • Ireland • Israel • Italy • Jamaica • Japan • Jordan • Korea • Kuwait • Lebanon • Malaysia • Mexico • Netherlands • New Zealand • Norway • Pakistan • Peru • Philippines • Poland • Portugal • Puerto Rico • Qatar • Romania • Russia-CIS • Saudi Arabia • Singapore • Slovakia • Slovenia • South Africa, Republic • Spain • Sweden • Switzerland • Taiwan • Thailand • Turkey • United Arab Emirates • United Kingdom • United States • Uruguay • Venezuela • Yugoslavia

Allen-Bradley Headquarters, 1201 South Second Street, Milwaukee, WI 53204 USA, Tel: (1) 414 382-2000 Fax: (1) 414 382-4444