

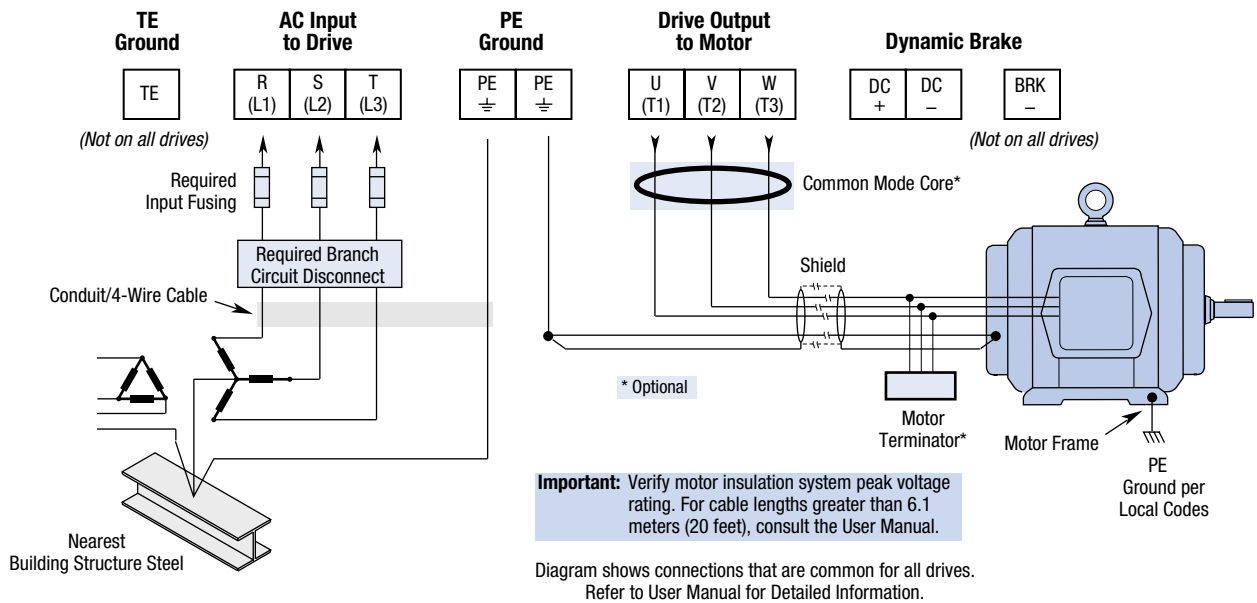

# 1336 PLUS II Quick Start Guide

This Quick Start Guide summarizes the basic steps needed to install, start-up and program the 1336 PLUS II Adjustable Frequency AC Drive. The information provided **Does Not** replace the User Manual and is intended for qualified drive service personnel only. Refer to the 1336 PLUS II User Manual (publication 1336 PLUS-5.3) for details on other application considerations and related precautions.

## Power Wiring – TB1



## Digital Outputs – TB2

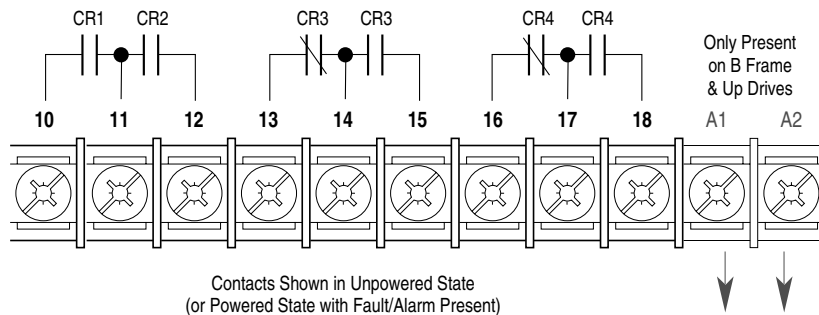

Terminal	Signal
TE	True Earth - Shield Termination
10, 11	CR1 Programmable Contact
11, 12	CR2 Programmable Contact
13, 14	CR3 Programmable Contact
14, 15	
16, 17	CR4 Programmable Contact
17, 18	
A1, A2	Reserved for Future Use

Resistive Rating = 115V AC/30V DC, 5.0A  
Inductive Rating = 115V AC/30V DC, 2.0A

**Important:** On A Frame Drives, the power supply used for relay contact outputs requires a field installation of transient voltage surge suppression with maximum clamping voltage of 2.5 kV on all control boards.

## Digital Inputs – TB3



A hazard of personal injury from automatic restart exists with 2-wire control. 2-wire control uses maintained Run contacts that act as both Run (closed) and Stop (open) devices. Opening the Stop contact (terminal 20) will stop the drive. If this contact is reclosed, any fault will be reset. If a valid Start command is still present, the drive will restart. Only use 2-wire control for applications outlined in NFPA79, "Under Voltage Protection."

If a 3-wire device (i.e. HIM) is also used, pressing the HIM Stop key will also stop the drive. Releasing the Stop key will clear any faults that are present, but the drive will not restart without cycling the Start contact.

### Speed Select Input State vs. Frequency Source

Speed Select 3	Speed Select 2	Speed Select 1	Frequency Source
Open	Open	Open	[Freq Select 1]
Open	Open	Closed	[Freq Select 2]
Accessed through [Freq Select 2] parameter			[Preset Freq 1]
Open	Closed	Open	[Preset Freq 2]
Open	Closed	Closed	[Preset Freq 3]
Closed	Open	Open	[Preset Freq 4]
Closed	Open	Closed	[Preset Freq 5]
Closed	Closed	Open	[Preset Freq 6]
Closed	Closed	Closed	[Preset Freq 7]

**Important:** The final speed command may be affected by the type of modulation selected with [Speed Control], parameter 77. Refer to [Speed Control] in Chapter 6 of the User Manual for further information.

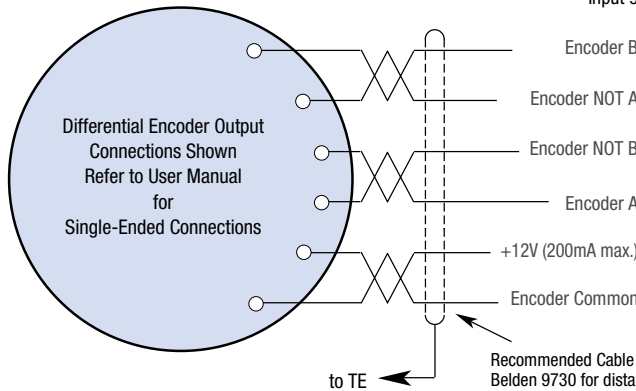

Recommended Cable (or equivalent):  
 Belden 9730 for distances less than 30 meters (98 feet)  
 Belden 9773 for distances greater than 30 meters (98 feet)

### Input Mode (Start/Stop Functions Only)

Status <sup>2</sup> (Factory Default)	2-Wire Control Single-Source Control	3-Wire Control Single-Source Reversing
--	---	---

Status	Run Forward	Start
Stop/Fault Reset <sup>3</sup>	Stop/Fault Reset <sup>3</sup>	Stop/Fault Reset <sup>3</sup>

### Factory Default Inputs

Terminal	Function	Programmable
Common	Common	
Input 3	Rev/For <sup>4</sup>	(Programmable)
Input 4	Jog	(Programmable)
Input 5	Auxiliary <sup>3</sup>	(Programmable)
Common	Common	
Input 6	Speed Select 3 <sup>1</sup>	(Programmable)
Input 7	Speed Select 2 <sup>1</sup>	(Programmable)
Input 8	Speed Select 1 <sup>1</sup>	(Programmable)
Common	Common	
Input 9	Enable <sup>3</sup>	(Not Programmable)

Status Only  
 Default Mode shown at right is not active when [Input Mode] is set to "Status"

Included on L4E through L9E Only

- See Speed Select Table.
- If this mode is selected, the status of all inputs can be read at the [Input Status] parameter. However, only "Stop/Fault Reset" and "Enable" will have control function.
- These inputs must be present (reprogram if necessary) before drive will start.
- Bit 0 of [Direction Mask] must = 1 to allow TB3 direction change/bipolar operation.

## Jumper Locations

### Connector J9

TB2-4	Common
TB2-3	Input 1
TB2-2	Input 0
TB2-1	Pot Ref. (5V)

Text Does Not Appear on Board (for explanation purposes only)  
 Remaining Pins Not Shown

### Connector J10

TB2-9	Common
TB2-8	Output 1
TB2-7	Output 0
TB2-6	Input 2

Text Does Not Appear on Board (for explanation purposes only)  
 Remaining Pins Not Shown

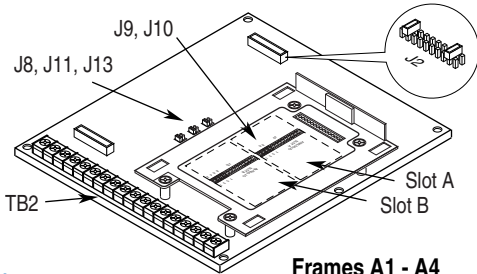

Frames A1 - A4

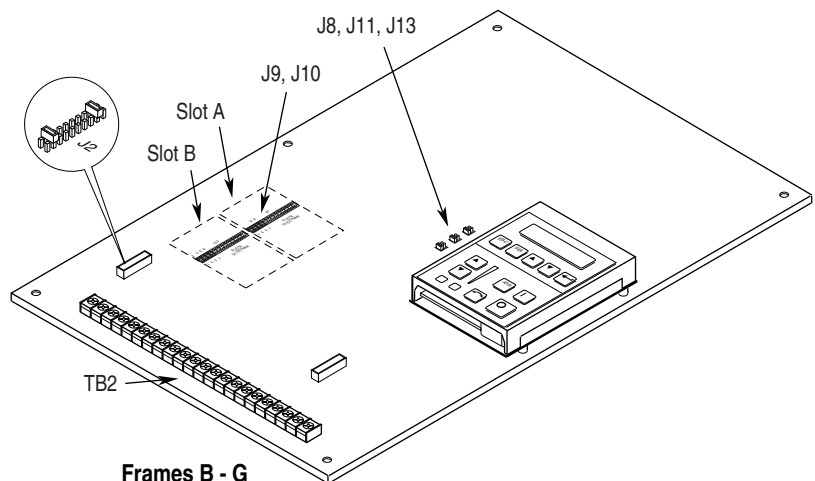

Frames B - G

## Analog I/O – TB2

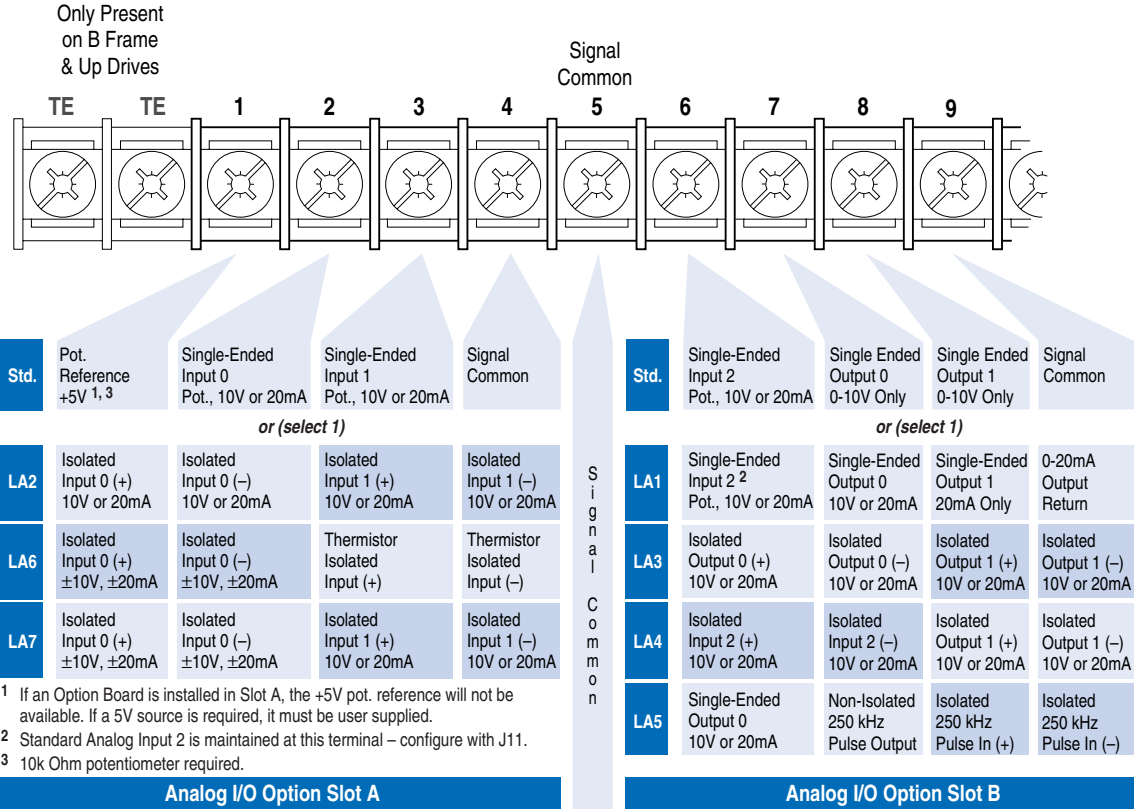

## Start-Up

This start-up procedure covers only the most commonly adjusted values using the 1336 PLUS II “Startup” mode. Refer to the User Manual for detailed information.

The following procedure is written for users who have a Human Interface Module (HIM) installed. For users without a HIM, respective external commands and signals must be supplied. It is also assumed that all parameters are at factory default settings. Pay particular attention to steps marked with a “✓”.



**ATTENTION:** Power must be applied to the drive to perform the following. Some of the voltages present are at incoming line potential. To avoid electric shock hazard or damage to equipment, only qualified drive service personnel should perform the following procedure. Thoroughly read and understand the procedure before beginning. If an event does not occur while performing this procedure, Do Not Proceed. Remove Power by opening the branch circuit disconnect device and correct the malfunction before continuing.



**ATTENTION:** To avoid a hazard of electric shock when wiring or servicing the drive, verify that the voltage on the bus capacitors has discharged. Measure the DC bus voltage at the + & – terminals of TB1. The voltage must be zero.



**ATTENTION:** To guard against possible machine damage and/or personal injury caused by unintended motor rotation, Do Not press the Start key (HIM) or issue a Start command (TB3) during this Start-Up procedure until instructed to do so. Pressing the Start key or issuing a Start command will cause the drive to start.

1. Verify that AC line power and control power match the drive rating.
- ✓  2. Disconnect the load from the motor.
- ✓  3. If a Control Interface option is installed, verify that the Stop and Enable interlock inputs are present. If this option is not installed, verify that jumpers are installed at pins 3 & 4 and 17 & 18 of J2. In addition, [Input Mode] must be set to “Status.” See page 2 for jumper locations.
4. If standard I/O is being used, verify that jumpers J8, J11 & J13 are properly set. Refer to figure at right.

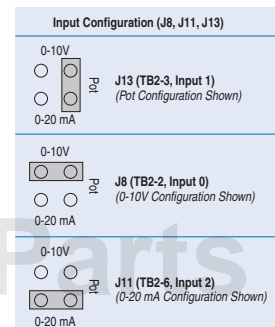

- 5. If Analog Option is installed, verify that DIP switch(es) are properly set (refer to Option Instruction Sheet).



**ATTENTION:** In all of the following steps, rotation of the motor may occur. To guard against injury, incorrect rotation and possible equipment damage, read each step carefully and perform with caution.

- 6. Apply AC power and control voltages to the drive, the LCD display should light and display a drive status of “Stopped” and an output frequency of “+0.00 Hz.” If the drive detects a fault, a statement relating to the fault will be shown on the display – Record this information, remove power and correct the fault source before proceeding.
- 7. From the Status Display, press the Enter key (or any key). “Choose Mode” will be displayed. Press the Increment (or Decrement) key until “Startup” is displayed. Press Enter.

**Important:** All questions can be answered Yes or No. Pressing Enter will select the default (“Y” or “N”). Pressing the Increment (or Decrement) key will change the selection - press Enter to select. Choosing “Y” allows you to proceed through the step, “No” will advance you to the next step. The figure below shows the steps involved.

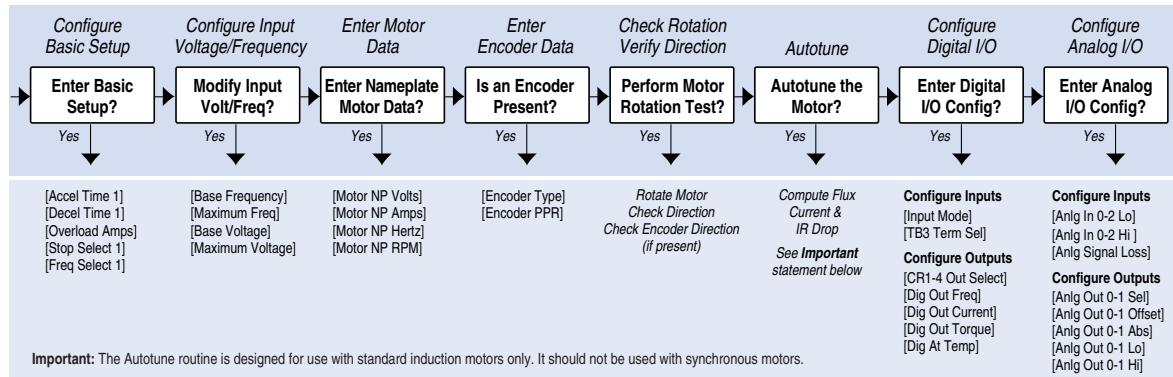

**Important:** Please note the following:

- The “Startup” mode can be exited at any time by pressing ESCape until the Status Display is shown. If you wish to re-enter the “Startup” mode, simply select “Reset Sequence” to start from the beginning. Selecting “Continue” allows you to resume from the point where you left off.
  - Completing the last action in any step will automatically take you to the next step.
  - Pressing SElect will activate line 2 of the display – this must be done for all values.
  - Press the Increment (or Decrement) key to adjust a value (skip if value is correct). Press Enter to store the value or retain existing value. Pressing Enter again will cause you to move to the next step (parameter).
- 8. Remove all power, then reconnect load to motor. This completes the “Assisted Startup” procedure. Depending on your application, further parameter programming and/or “Advanced Startup” may be required – refer to the User Manual for details.

## HIM Operation

Parameter programming (or viewing) is accomplished through the Program or Display modes as shown below.

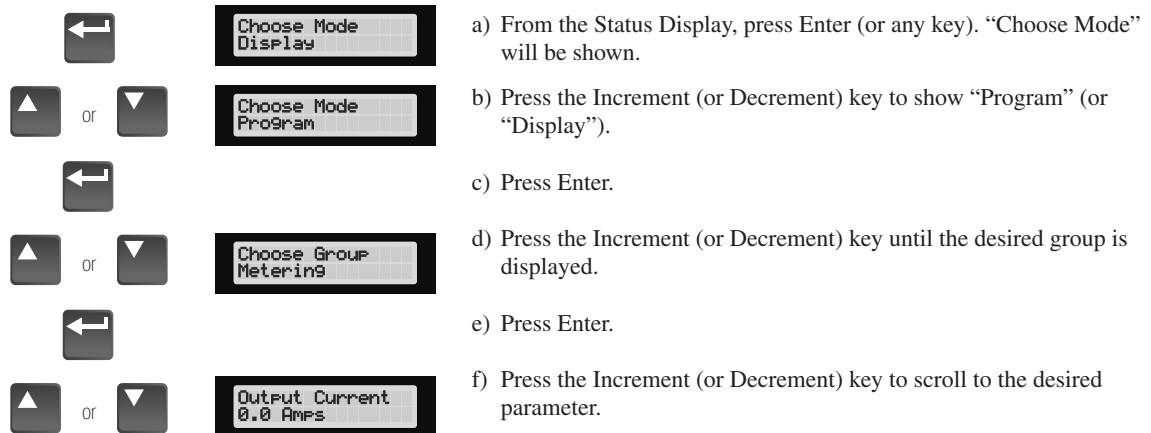

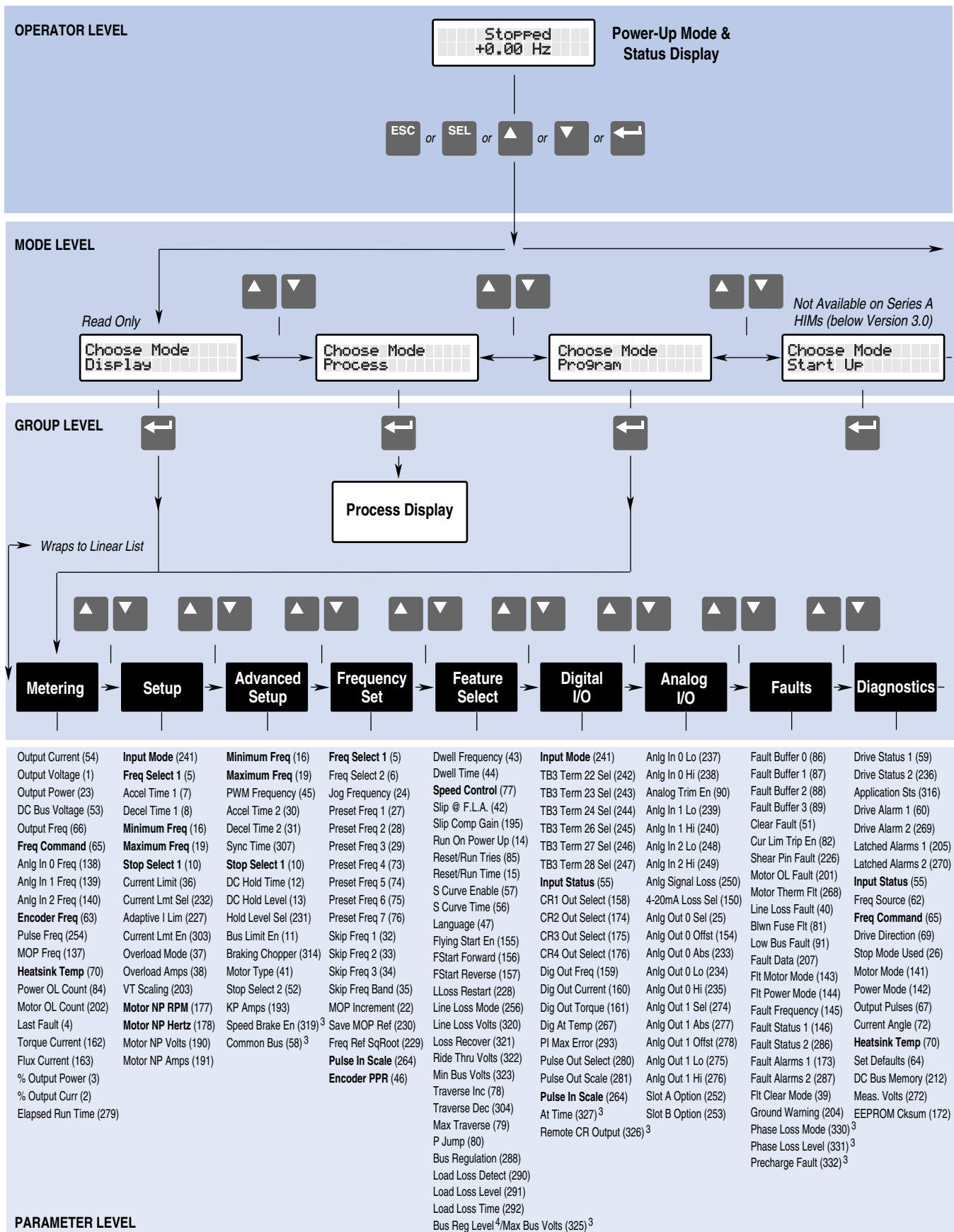

Spare Allen-Bradley Parts

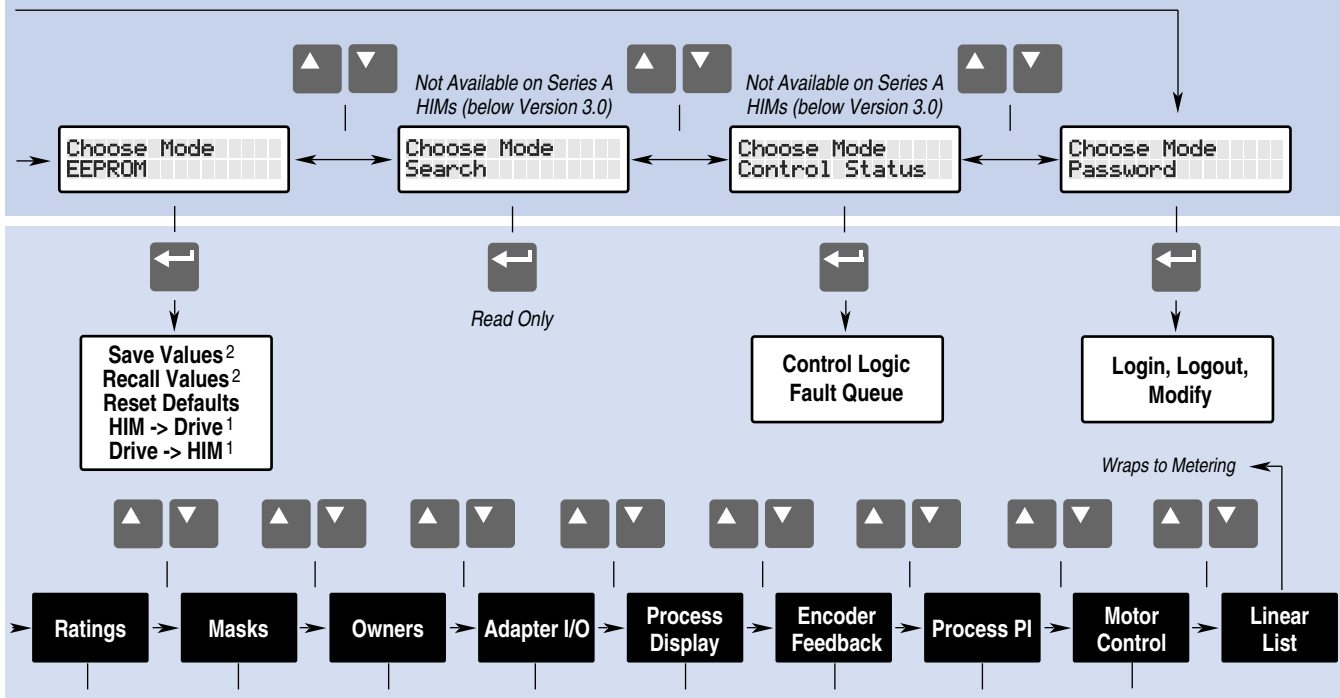

Rated Volts (147)	Direction Mask (94)	Stop Owner (102)	Data In A1 (111)	Process 1 Par (127)	<b>Speed Control</b> (77)	<b>Speed Control</b> (77)	Control Select (9)
Rated Amps (170)	Start Mask (95)	Direction Owner (103)	Data In A2 (112)	Process 1 Scale (128)	Encoder Type (152)	PI Config (213)	Flux Amps Ref (192)
Rated kW (171)	Jog Mask (96)	Start Owner (104)	Data In B1 (113)	Process 1 Txt 1 (129)	<b>Encoder PPR</b> (46)	PI Status (214)	IR Drop Volts (194)
Firmware Ver. (71)	Reference Mask (97)	Jog Owner (105)	Data In B2 (114)	Process 1 Txt 2 (130)	Maximum Speed (151)	PI Ref Select (215)	Flux Up Time (200)
Cntrl Board Rev (251)	Accel Mask (98)	Reference Owner (106)	Data In C1 (115)	Process 1 Txt 3 (131)	Motor Poles (153)	PI Fdbk Select (216)	Start Boost (48)
Rated CT Amps (148)	Decel Mask (99)	Accel Owner (107)	Data In C2 (116)	Process 1 Txt 4 (132)	Speed KI (165)	PI Reference (217)	Run Boost (83)
Rated CT kW (149)	Fault Mask (100)	Decel Owner (108)	Data In D1 (117)	Process 1 Txt 5 (133)	Speed KP* (164)	PI Feedback (218)	Boost Slope (169)
Rated VT Amps (198)	MOP Mask (101)	Fault Owner (109)	Data In D2 (118)	Process 1 Txt 6 (134)	Speed Error (166)	PI Error (219)	Break Voltage (50)
Rated VT kW (199)	Traverse Mask (305)	MOP Owner (110)	Data Out A1 (119)	Process 1 Txt 7 (135)	Speed Integral (167)	PI Output (220)	Break Frequency (49)
Drive Type (61)	Sync Mask (308)	Traverse Owner (306)	Data Out A2 (120)	Process 1 Txt 8 (136)	Speed Adder (168)	KI Process (221)	Base Voltage (18)
	Logic Mask (92)	Sync Owner (309)	Data Out B1 (121)	Process 2 Par (180)	Slip Adder (255)	KP Process (222)	Base Frequency (17)
	Local Mask (93)	Local Owner (179)	Data Out B2 (122)	Process 2 Scale (181)	<b>Motor NP RPM</b> (177)	PI Neg Limit (223)	Maximum Voltage (20)
	Alarm Mask 1 (206)		Data Out C1 (123)	Process 2 Txt 1 (182)	<b>Motor NP Hertz</b> (178)	PI Pos Limit (224)	Run/Accel Volts (317)
	Alarm Mask 2 (271)		Data Out C2 (124)	Process 2 Txt 2 (183)	Encoder Counts (283)	PI Preload (225)	Sync Loss Sel (310)
			Data Out D1 (125)	Process 2 Txt 3 (184)	Enc Count Scale (282)		Sync Loss Gain (311)
			Data Out D2 (126)	Process 2 Txt 4 (185)	Encoder Loss Sel (284)		Sync Loss Comp (313)
			Alt Type 2 Cmd (315)	Process 2 Txt 5 (186)	<b>Encoder Freq</b> (63)		Sync Loss Time (312)
				Process 2 Txt 6 (187)	Max Enc Counts (328) <sup>3</sup>		PWM Comp Time (333) <sup>4</sup>
				Process 2 Txt 7 (188)			Break Freq (334) <sup>4</sup>
				Process 2 Txt 8 (189)			

<sup>1</sup> Series B & Up Handheld HIM Only

<sup>2</sup> Reserved for Future Use

<sup>3</sup> Firmware Version 3.001 & later

<sup>4</sup> Firmware Version 4.001 & later

**Note:** Parameters that appear in more than one group are shown in **Bold** – Parameter Numbers are shown in (parenthesis). An asterisk (\*) indicates that the parameter was not functional at time of printing.