



1336 PLUS Adjustable Frequency AC Drive DC Bus Fuse Replacement D Frame Drives

This publication will guide you through replacement of the DC bus fuse assembly on D Frame 1336 PLUS AC Drives.

Use the table below to verify that the correct Fuse Kit was received.

Drive Catalog Number	Fuse Kit Catalog Number	Fuse Rating (Amperes)
1336S-A040	1336-CONV-SP15A	250
1336S-A050	1336-CONV-SP16A	300
1336S-A060	1336-CONV-SP17A	350
1336S-B060	1336-CONV-SP14A	200
1336S-B075	1336-CONV-SP15A	250
1336S-B100	1336-CONV-SP16A	300
1336S-B125	1336-CONV-SP17A	350
1336S-BX150	1336-CONV-SP17A	350
1336S-C075	1336-CONV-SP14A	200
1336S-C100	1336-CONV-SP15A	250
1336S-C125	1336-CONV-SP16A	300

Each kit consists of the following components:

Component Description	Quantity
Bus Bar, Upper & Lower	1 each
Diode with Lead, Lug & Screw	1 each
Fuse	1
Screw Assembly with Washer & Lockwasher	2
Nut/Washer	2
Flat Washer	2
Label	1
Insulating Paper	1



ATTENTION: This drive contains ESD (Electrostatic Discharge) sensitive parts and assemblies. Static control precautions are required when installing, testing, servicing or repairing this assembly. Component damage may result if ESD control procedures are not followed. If you are not familiar with static control procedures, reference publication 8000-4.5.2, “Guarding Against Electrostatic Damage” or any other applicable ESD protection handbook.



ATTENTION: To avoid a shock hazard, assure that all power to the drive has been removed before proceeding. In addition, verify that the DC bus has discharged by measuring across the “+DC” and “-DC” terminals of TB1 with a voltmeter. The voltage should be 0.0VDC.

1. Remove and lock-out all incoming power to the drive.
2. Remove the drive front cover and clear protective guard to gain access to the DC bus fuse.
3. Remove the existing fuse. Discard the fuse and bolts.
4. Install, but do not tighten the new fuse to the supplied bus bars (see figure below). Secure the diode to the upper bus bar.
5. Mount, but do not tighten the bus bars (with fuse and diode) using the hardware shown. Pay particular attention to the screw, lug, washer combination on the lower bus bar. When bus bars are correctly positioned, tighten hardware to 11.0-12.5 N-m (97-111 lb.-in.). When tightening, hold lug to guard against movement.
6. Remove the adhesive strip from the insulating paper and position on the underside of the protective guard to shield the new fuse. Replace the guard. Install the new fuse label over the existing label on the guard. Replace the front cover.



ATTENTION: Replace any guards previously removed before applying power to the drive. Failure to replace guards may result in death or serious injury.

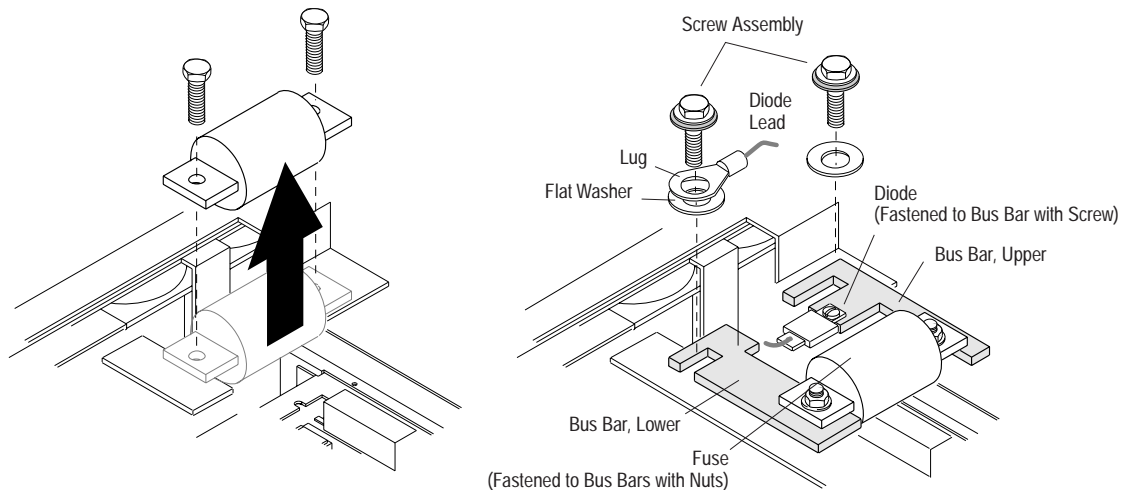

 **Rockwell Automation**
Allen-Bradley

Rockwell Automation helps its customers receive a superior return on their investment by bringing together leading brands in industrial automation, creating a broad spectrum of easy-to-integrate products. These are supported by local technical resources available worldwide, a global network of system solutions providers, and the advanced technology resources of Rockwell.

Worldwide representation.



Argentina • Australia • Austria • Bahrain • Belgium • Bolivia • Brazil • Bulgaria • Canada • Chile • China, People's Republic of • Colombia • Costa Rica • Croatia • Cyprus • Czech Republic • Denmark • Dominican Republic • Ecuador • Egypt • El Salvador • Finland • France • Germany • Ghana • Greece • Guatemala • Honduras • Hong Kong • Hungary • Iceland • India • Indonesia • Iran • Ireland • Israel • Italy • Jamaica • Japan • Jordan • Korea • Kuwait • Lebanon • Macau • Malaysia • Malta • Mexico • Morocco • The Netherlands • New Zealand • Nigeria • Norway • Oman • Pakistan • Panama • Peru • Philippines • Poland • Portugal • Puerto Rico • Qatar • Romania • Russia • Saudi Arabia • Singapore • Slovakia • Slovenia • South Africa, Republic of • Spain • Sweden • Switzerland • Taiwan • Thailand • Trinidad • Tunisia • Turkey • United Arab Emirates • United Kingdom • United States • Uruguay • Venezuela

Rockwell Automation Headquarters, 1201 South Second Street, Milwaukee, WI 53204-2496 USA, Tel: (1) 414 382-2000, Fax: (1) 414 382-4444