



Allen-Bradley

***Bulletin 1365
DC Drive***

**User
Manual**

Allen-Bradley S

Important User Information

Because of the variety of uses for the products described in this publication, those responsible for the application and use of this control equipment must satisfy themselves that all necessary steps have been taken to assure that each application and use meets all performance and safety requirements, including any applicable laws, regulations, codes and standards.

The illustrations, charts, sample programs and layout examples shown in this guide are intended solely for purposes of example. Since there are many variables and requirements associated with any particular installation, Allen-Bradley does not assume responsibility or liability (to include intellectual property liability) for actual use based upon the examples shown in this publication.

Allen-Bradley publication SGI-1.1, *Safety Guidelines for the Application, Installation, and Maintenance of Solid-State Control* (available from your local Allen-Bradley office), describes some important differences between solid-state equipment and electromechanical devices that should be taken into consideration when applying products such as those described in this publication.

Reproduction of the contents of this copyrighted publication, in whole or in part, without written permission of Rockwell Automation, is prohibited.

Throughout this manual we use notes to make you aware of safety considerations:



ATTENTION: Identifies information about practices or circumstances that can lead to personal injury or death, property damage or economic loss.

Attention statements help you to:

- identify a hazard
- avoid the hazard
- recognize the consequences

Important: Identifies information that is critical for successful application and understanding of the product.

Chapter 1: Receiving, Inspection & Storage

Receiving 1-1
 Inspection 1-1
 Storage 1-1

Chapter 2: Specification

Catalog Number Explanation 2-1
 Functional Description 2-2
 Controller Specification 2-5
 Ratings 2-5
 Controller Performance 2-6
 Speed Control Adjustment Ranges 2-7
 Torque Control Adjustment Ranges 2-8

Chapter 3: Installation

Installing the Drive 3-1
 Terminal Board Locations 3-3
 Chassis Dimensions 3-5
 Installing the Motor 3-7
 Install a Disconnect 3-7
 Wiring the Drive 3-9
 Ground the Controller and Enclosure 3-9
 Wiring AC power to the Controller 3-10
 Wiring DC power to the Controller 3-11
 Wiring the Start/Stop Circuit 3-13
 Wiring the Run/Jog Circuit 3-15
 Wiring the Signal Potentiometer 3-15
 Wiring the Process Control and/or Automatic/Manual
 Devices (if required) 3-16
 Wiring the DC Tach Speed Feedback Signal 3-17
 Installing Fuse Kits 3-19

Chapter 4: Startup and Adjust the Drive

Position the Controller Jumpers 4-1
Startup and Adjust the Controller 4-7
Setup for Process Interface 4-13
Adjust Rate Potentiometer(s) 4-14

Chapter 5: Troubleshooting

General 5-1
Troubleshooting Table 5-1
Spare Parts 5-5
Wiring Diagrams 5-6
Switch Configurations 5-8
Operator Device Interconnections 5-9

Receiving, Inspection and Storage

Receiving

It is the responsibility of the user to thoroughly inspect the equipment before accepting the shipment from the freight company. Check the item(s) received against the purchase order. If any items are obviously damaged, it is the responsibility of the user not to accept delivery until the freight agent has noted the damage on the freight bill. Should any concealed damage be found during unpacking, it is again the responsibility of the user to notify the freight agent. The shipping container must be left intact and the freight agent should be requested to make a visual inspection of the equipment.

Remove all packing material, wedges, or braces from within and around the drive. Remove all packing material from the cooling fans (when equipped) and the heat sink.

Inspection

After unpacking, check the item(s) nameplate catalog number against the purchase order. An explanation of the catalog numbering system for the 1365 Drive is included as an aid for nameplate interpretation. Refer to the following pages for complete nomenclature.

Storage

The drive should remain in its shipping container prior to installation. If the equipment is not to be used for a period of time, it must be stored according to the following instructions in order to maintain warranty coverage:

- Store in a clean, dry location.
- Store within an ambient temperature range of 0°C (32°F) to 65°C (149°F).
- Store within a relative humidity range of 5% to 95% non-condensing.
- Do not store equipment where it could be exposed to a corrosive atmosphere.
- Do not store equipment in a construction area.

This Page Intentionally Blank

2: Specification

Catalog Number Explanation

The Bulletin 1365 controller converts single-phase AC line power to adjustable DC power for either speed or torque control of DC motors rated 1/4 through 2 HP. This includes permanent magnet or wound field D-C motors with compatible armature and field voltages.

The controller is available in a wide array of application-specific configuration, open chassis or NEMA Type 4/12 enclosure designs.

Note: When the RE020 DC Tachometer is used, a controller isolation transformer must be used. See Installing a Disconnect in Chapter 3 of this instruction manual for instructions.

Table 2.A Open Chassis Controllers

Enclosure Type	A-B Catalog #	Description
Chassis	1365-SAN	1/4 - 2HP Basic Start/Stop Speed Input
Chassis	1365-PAN	1/4 - 2HP Basic Process Control
Chassis	1365-TAN	1/4 - 2HP Torque Regulation

Table 2.B NEMA 12 Enclosed Controller Listed by Features and Configuration

Enclosure Type	A-B Catalog #	Description
NEMA 4/12	1365-SAF	1/4 - 2HP Basic Start/Stop Speed Input
NEMA 4/12	1365-DAF	1/4 - 2HP Basic DB/Reversing
NEMA 4/12	1365-PAF	1/4 - 2HP Basic Process Control
NEMA 4/12	1365-TAF	1/4 - 2HP Torque Regulation

Table 2.C

Fuse Type	A-B Catalog #	Description
Fuses	1365-FU1	Fuses for open type 1365-SAN, PAN, TAN
Fuses	1365-FU2	For enclosed type 1365-SAF, PAF, TAF

Functional Description

Standard controllers available are listed in Tables 2.A, 2.B and 2.C.

Basic Controller Features (All Models)

- A-C line power reconnectable for single-phase 115 or 230 volts:
 - 115 volts AC: 90 volt DC armature/50 volt DC field supply
 - 230 volts AC: 180 volt DC armature/100 volt DC field supply
- 50 or 60 Hertz power without modification
- Full-wave, half-controlled armature voltage rectifier with back diode for improved armature form factor
- Half-wave field supply for shunt wound DC motors
- Optional short circuit protection by incoming line fuse
- Line transient protection by metal oxide varistor and RC circuit
- Armature current scaling by reconnectable jumper for horsepower rating
- Unidirectional operation with coast-to-rest Stop
- Motor overload protection by internal motor thermostat
- Provisions for remote Start, remote Stop and/or remote Run/Jog

Speed Control Features Catalog

1365-SAN, 1365-PAN, 1365-SAF, 1365-DAF, 1365-PAF

- All features listed in “Basic Controller Features (All Models)”
- Speed control by armature voltage regulation or motor mounted DC tachometer (except 1365-DAF)
- Potentiometer motor speed adjustment
- Separately adjustable maximum and minimum speeds
- Independently adjustable rates
- Adjustable current limit
- Jumper selectable Armature voltage feedback scaling (90 or 180 volts)
- Adjustable IR drop compensation

Speed Control with Reversing and Dynamic Braking 1365-DAF

- All features listed in “Basic Controller Features (All Models)” and “Speed Control Features”
- Reversing direction of rotation by a Forward/Off/Reverse switch. The “Off” position (or center position of the switch) applies dynamic braking (braking capabilities listed in Table 2.E).
- Selector switch has detent feature which requires release of pressure on the switch when passing from forward to reverse. When combined with the dynamic braking action, this feature minimizes the possibility of plug reversing the motor.



ATTENTION: The drive must be at zero speed before changing the direction of rotation. Failure to observe this precaution could result in damage to the motor or any equipment.

Speed Control with Isolated Process Control Interface 1365-PAN, 1365-PAF

- All features listed in “Basic Controller Features (All Models)” and “Speed Control Features”
- Motor speed adjustment by potentiometer (Manual mode) or process control output signal (Automatic mode)
- Manual/Automatic mode switching by selector switch
- Process control signal input selection by jumper: 1 to 5 mA, 4 to 20 mA, 10 to 50 mA, or 0 to 10 volts reference signal, grounded or ungrounded
- Isolated input 300K ohm differential
- Process interface (PI) gain adjustment
- Process interface (PI) bias adjustment
- Ramp generator
- Auxiliary form C contact for run indication

Basic Torque Control Features (1365-TAN, 1365-TAF)

- All features listed in “Basic Controller Features (All Models)”
- Motor torque adjustment by potentiometer
- Independently adjustable maximum and minimum torque
- Independently adjustable rate reference timing
- Adjustable speed limit by voltage limit or motor mounted DC tachometer feedback
- Jumper selectable armature voltage feedback scaling (90 or 180 volts)
- Ramp generator
- Auxiliary form C contact for run indication

Jog Function

Cat 1365-SAN

- All features listed in “Basic Controller Features (All Models)”
- Controller offers Run/Jog capability for local or remote requirements.
- Only available in chassis construction

Controller Specifications

Ratings

- Service factor 1.0
 - Continuous duty
 - Load capacity: 150% for 1 minute
 - Line voltage variation: $\pm 10\%$ of rated
 - A-C line frequency: 48 to 62 Hertz
 - Maximum allowable symmetrical AC line fault current: 10,000 amperes
 - Maximum A-C line distribution system KVA capacity^{①②}
Maximum KVA:
 - 115-volt A-C input: 65.0 KVA
 - 230-volt A-C input: 32.5 KVA
 - Controller ratings by motor horsepower: Refer to Table 2.D
 - Ambient temperature:
 - Open chassis
0° to 55°C (32° to 131°F)
 - NEMA/UL Type 4/12 enclosed:
0° to 40°C (32° to 104°F)
 - NEMA Type 4/12 enclosure is intended for use indoors primarily to provide a degree of protection against splashing water, and hose-directed water, seepage of water, and severe external condensation. Conduit hubs for water-resistant connection are provided at the conduit entrance and a means to mount these hubs external to the equipment cavity. The controller has passed the UL hosedown test to verify the washdown integrity of the controller.
- ① When applying 1365 drives to power distribution systems with a KVA capacity in excess of the maximum recommended KVA capacity, an isolation transformer or line reactor of similar impedance is required.
- ② Assumes a transformer impedance of 5%

Controller Performance

- Efficiency (at rated speed and load):
 - Controller - 97%
 - Controller and motor - 78%
- Displacement power factor (at rated speed and load): 70%

Table 2.D Controller Ratings by Motor Horsepower

Motor HP	115-Volt A-C Input					
	230-Volt A-C Input					
	Rated AC Line Amperes ^①	Input KVA	DC Armature Voltage	Rated Armature Current (amperes)	Available DC Field Voltage	Available Field Current (amperes)
1/4	3.1	0.36	90.0	2.5	50.0	2.0
	–	–	–	–	–	–
1/3	4.2	0.48	90.0	3.7	50.0	2.0
	–	–	–	–	–	–
1/2	6.2	0.71	90.0	5.0	50.0	2.0
	3.1	0.71	180.0	2.5	100.0	2.0
3/4	9.4	1.0	90.0	7.5	50.0	2.0
	4.7	1.0	180.0	3.7	100.0	2.0
1	12.5	1.4	90.0	10.0	50.0	2.0
	6.2	1.4	180.0	5.0	100.0	2.0
1-1/2	–	–	–	–	–	–
	9.4	2.2	180.0	7.5	100.0	2.0
2	–	–	–	–	–	–
	12.5	2.9	180.0	10.0	100.0	2.0

① Includes motor field current.

Table 2.E Controller Isolation Transformer Ratings

HP	Transformer KVA
1/4	0.75
1/3	0.75
1/2	1.50
3/4	1.50
1	2.00
1-1/2	3.00
2	5.00

Speed Control Adjustment Ranges

Note: Full rotation of potentiometers may exceed the range specified.

- Maximum speed: 50 to 100% of motor base speed with speed setting pot at its maximum setting
- Minimum speed: 10 to 50% of maximum speed with speed setting pot at its minimum setting. With zero speed jumper, minimum speed range is 0 to 50% of maximum speed.
- Current limit: adjustable to 150% of selected current range
- IR drop compensation: 5% to 10% at rated armature voltage
- Speed regulation characteristics: refer to Table 2.F.
- Ramp time to maximum speed: 0.5 to 30 seconds
- Enhanced acceleration/deceleration ramp time to maximum speed for Catalog No. 1365-PAN, 1365-TAN, 1365-PAF, 1365-TAF:
 - J-401, “slow” adjustable from 3.5 seconds to 40 seconds
 - J-401, “fast” adjustable from 0.3 seconds to 3.5 seconds
- Dynamic braking provided in catalog 1365-DAF only. This capability is designed for applications requiring stopping of loads in which the inertia reflected to the motor is approximately equivalent to or less than the motor armature inertia. Refer to Table 2.G.



ATTENTION: Do not use dynamic braking on application with reflected inertias higher than motor armature inertia or when stops are necessary. Failure to observe this precaution could result in damage to the equipment. Refer to Table 2.G for duty cycle.

- Isolated process follower input:
 - P.I. Gain 0.5 to 2.5
 - P.I. Offset $\pm 25\%$ of full reference

Torque Control Adjustment Ranges

- Maximum torque: 75 to 150% of rated motor torque with torque potentiometer at its maximum setting
- Minimum torque: 5 to 50% of maximum motor torque with torque potentiometer at its minimum setting
- Speed/Voltage limit: 20 to 110% base speed

Table 2.F Speed Regulation Characteristics.^①

Type of Regulation	Line Voltage $\pm 10\%$	Load Change 95%	Regulated Speed Range	Temperature $\pm 10^\circ\text{C}$	Field Heating Cold Normal ^②
Armature Feedback (Voltage)	0.1%	2-5% ^③	20:1	1.0%	5-12%
Tachometer Feedback (Speed) ^④	0.1%	1%	30:1	1.5%	0.5%

^① All percentages expressed relative to maximum speed.

^② Applies to wound field DC motors only.

^③ Dependent upon specific motor characteristics and IR drop compensation adjustment.

^④ Applicable to non-reversing models only.

Table 2.G Dynamic Braking Capabilities (with Reversing Switch, Catalog 1365-DAF only)

Description	Input Voltage	1/4	1/3	1/2	3/4	1	1-1/2	2
Braking Torque (% Full Load Torque)	115	129	103	66	44	34	-	-
	230	-	-	200	190	130	88	62
Allowable Stops Per Minute	115	12	11	8	6	2	-	-
	230	-	-	8	6	1	1	1

This Page Intentionally Blank

3: Installation



ATTENTION: Only qualified electrical personnel familiar with the construction and operation of this equipment and the hazards involved should install, adjust, operate and/or service this equipment. Read and understand this manual in its entirety before proceeding. Failure to observe this precaution could result in severe bodily injury or loss of life.



ATTENTION: The user is responsible for conforming to the National Electrical Code and all other applicable local codes. The Allen-Bradley Company cannot assume responsibility for the compliance or the noncompliance to any code, national, local or otherwise for the proper installation of this drive or associated equipment. A hazard of personal injury and/or equipment damage exists if codes are ignored during installation.



ATTENTION: This equipment is at line voltage when A-C power is connected. Disconnect and lockout all ungrounded conductors of the AC power line. Failure to observe these precautions could result in severe bodily injury or loss of life.

Installing the Drive

Review all installation and wiring instructions thoroughly before proceeding. Throughout the installation and wiring procedures, use Figure 3-1 or Figure 3-1A to locate adjustment potentiometers, terminal boards, special selector jumpers and pins. Wiring diagrams are given in Figures 5-1, 5-1A, 5-2 and 5-3.

1. Remove the controller cover and inspect for any physical damage. Report any shipping damage to the carrier.
2. Locate the controller where it will have the unrestricted ventilation area as indicated in Figure 3-2A and Figure 3-2B.
3. Make sure that ambient temperatures in the controller area are within 0°C and 40°C (32°F and 104°F) for enclosed controllers or 0°C and 55°C (32°F and 131°F) for chassis design controllers.
4. Route power and control/signal wiring through separate conduit openings provided in the bottom of the enclosed controller. The area above the controller must be kept clear of live electrical circuits to avoid accidental contact. (See Figure 3-2A and Figure 3-2B.)
5. Mount the controller in a vertical, upright position. See Figures 3-2A and 3-2B.
6. For NEMA Type 4/12 controllers use the water resistant conduit hubs supplied as standard to maintain the NEMA Type 4/12 enclosure rating.

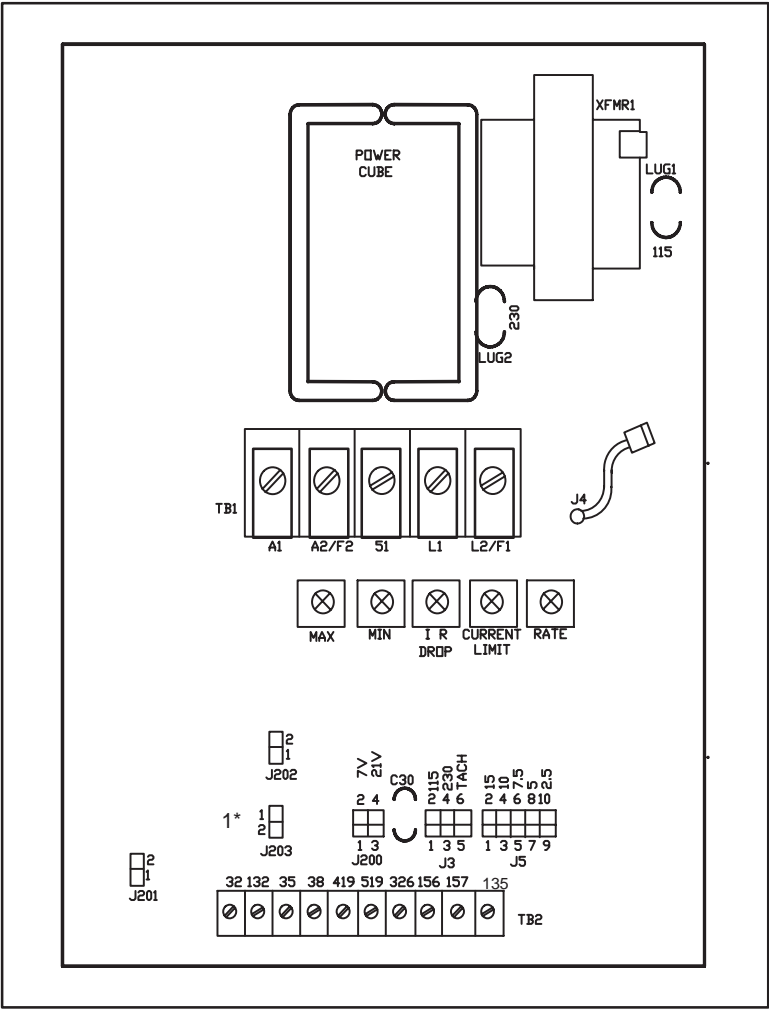

NOTES: 1* – Do Not Use

Figure 3-1. Controller Terminal Board Locations (Catalog 1365-SAN, 1365-SAF and 1365-DAF).

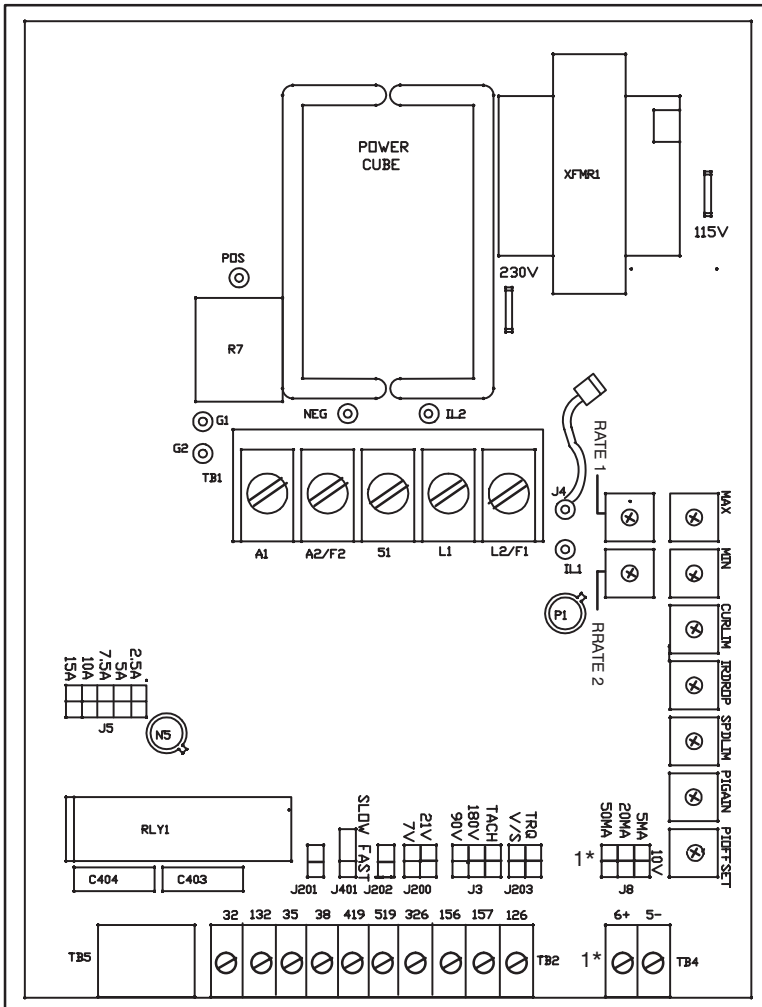

NOTE: 1* Functional on 1336-TAN and 1365-TAF ONLY.

Figure 3-1A. Controller Terminal Board Locations for Catalog 1365-PAN, 1365-TAN, 1365-PAF and 1365-TAF.

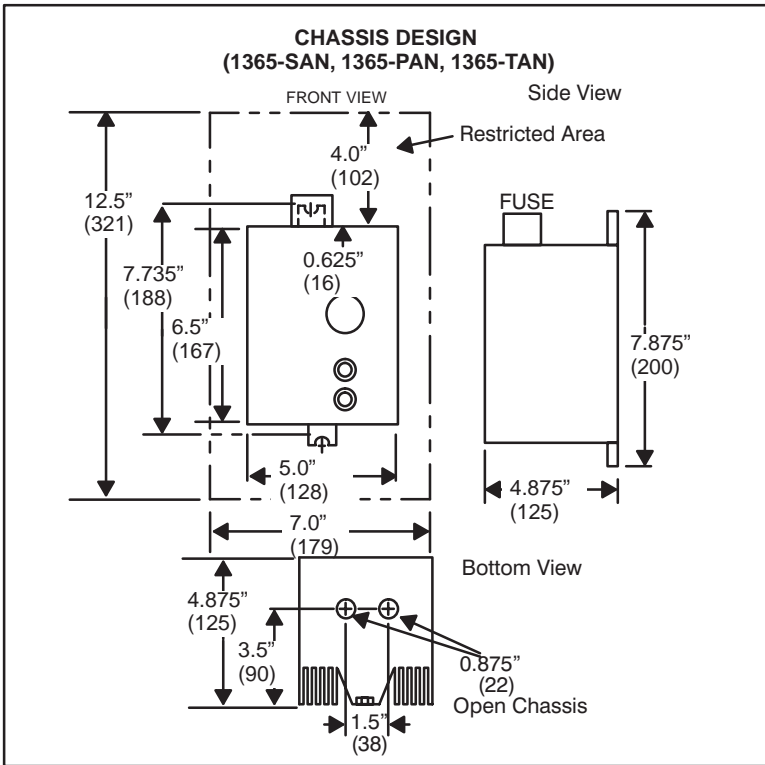

Figure 3-2A. Dimension and Mounting Data.

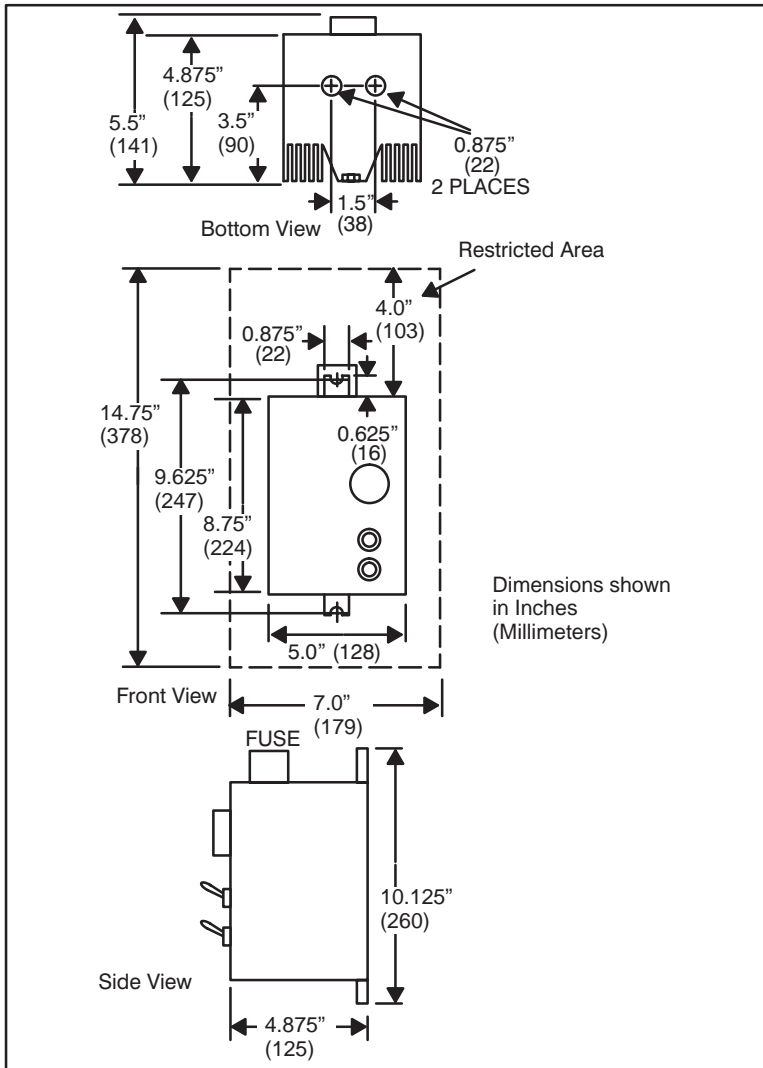

Figure 3-2B. Dimension and Mounting Data for 1365-SAF, 1365-DAF, 1365-PAF, 1365-TAF.

Installing the Motor

1. Verify that the motor is the appropriate rating to use with the controller.
2. Install the DC motor in accordance with its own installation instructions.
3. Make sure that coupled applications have proper shaft alignment with the driven machine or that belted applications have proper sheave/belt alignment to minimize unnecessary motor loading.

Install a Disconnect



ATTENTION: This equipment is at line voltage when AC power is connected. Disconnect and lockout all ungrounded conductors of the AC power line. Failure to observe these precautions could result in severe bodily injury or loss of life.



ATTENTION: All drives, with the exception of 1365-DAF, are not equipped with a fuse as standard. The customer must supply a Class J UL Listed and/or CSA Certified 20 amp, 600V time-delay fuse. Failure to observe this precaution could result in severe bodily injury or loss of life.

1. Any fused disconnect or circuit breaker in the incoming AC line must accommodate a maximum symmetrical AC fault current of 10,000 amperes. See Figure 3-3.
2. All drives are shipped without a fuse on the panel (Exception - Catalog 1365-DAF) therefore the customer must provide an external fuse (Class J UL Listed and CSA Certified 20 amp, 600V time-delay fuse).

- When the RE-020 DC tachometer option is used, a controller isolation transformer must be used between the AC power source and the controller to isolate the controller from the AC power source ground. Each such controller must have its own isolation transformer. The controller chassis must still be tied to the building ground system at the grounding point provided. The transformer is sized per Table 2-D. To eliminate the need for a transformer, use the insulated RE-007 tachometer option and the 1365 controller. An auto transformer cannot be used since it will not provide isolation from ground.



ATTENTION: A start/stop switch that does not include an AC power disconnect function in the Stop position is not recommended for use with the 1365 drive. The 1365 drive does not have an armature loop contactor and a single fault like a thyristor short could cause motor rotation when in the stop mode, if used with a switch that did not disconnect AC power. If a Start/Stop switch without a power disconnect function is used, an AC power disconnect switch **MUST** be mounted next to the operator controls. Failure to observe this precaution could result in bodily injury.

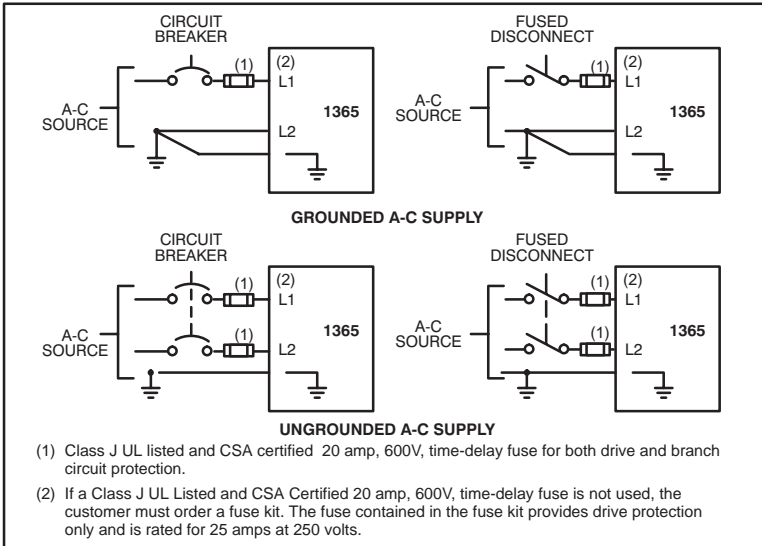

Figure 3-3. Fused Disconnect or Circuit Breaker Connections.

Wiring the Drive



ATTENTION: The user is responsible for conforming to the National Electrical Code and all other applicable local codes. Failure to comply with codes could result in severe bodily injury or loss of life.



ATTENTION: This equipment is at line voltage when AC power is connected. Disconnect and lockout all ungrounded conductors of the AC power line. Failure to observe these precautions could result in severe bodily injury or loss of life.

Note: All remote operation wiring must not exceed 250 feet.

Ground the Controller and Enclosure, the Motor and the Operator's Control Station.



ATTENTION: Connect the ground wire brought in with the incoming AC power line to the controller ground point. Connect an appropriate equipment grounding conductor unbroken from the controller ground point, the motor frame, the transformer enclosure if used, the controller electrical enclosure, the wiring conduits, and the operator's control station to an appropriate grounding electrode. Failure to observe this precaution could result in severe bodily injury or loss of life.

1. Locate the ground point provided at the bottom edge of the heat sink.
2. Run a suitable equipment grounding conductor **unbroken** from this controller ground point to the plant ground (grounding electrode). A ring lug is required at the ground point.
3. Connect a suitable grounding conductor from each conduit to this controller ground point (Figure 5.1 & 5.1A).

4. Connect a suitable equipment grounding conductor to the motor frame, the transformer enclosure if used, and the controller enclosure. Run this conductor **unbroken** to the grounding electrode (Figures 5-1 & 5-1A).
5. Connect the ground wire brought in with the incoming AC power line to the controller ground point.

Wiring AC Power to the Controller



ATTENTION: Do not operate the controller with available short-circuit currents in excess of 10,000 amperes. Failure to observe this precaution could result in severe bodily injury or loss of life.

1. Size the AC line supply conductors for the specific controller rating and according to all applicable codes.
2. Run the AC line supply through a conduit entry in the bottom of the controller to terminals TB1-L1 and TB1-L2/F1.

Wiring the DC Motor to the Controller

1. Size the motor armature circuit conductors A1 and A2 according to all applicable codes.
2. Run the DC motor armature leads and the shunt field supply leads (if a permanent magnet field motor is not used) through the same conduit entry used for the AC line supply.
3. Use the appropriate tightening torque as listed in Table 3.A for wire connections to input and output terminals.

Table 3.A. Terminal Strip TB1/TB2 Tightening Torques (lbs-in).

TB	Terminals	Torque
TB1	Input Terminals 51, L1, L2/F2	All: 9 minimum - 12 maximum in-lbs
TB1	Output Terminals A1, A2/F2	
TB2	Thermostat 32, 132	4 in-lbs



ATTENTION: If motors other than a straight shunt are used with the 1365 controller and an S1 and S2 winding is present on the motor, additional motor connections other than those detailed in this instruction manual are applicable. Refer to the motor manufacturer instructions when wiring other types of motors. Failure to observe this precaution could result in damage to the equipment.

- For ALL Catalogs (except 1365-DAF): If CCW motor rotation is desired (looking from the back of the motor or the shaft end), connect motor armature leads A1 and A2 to controller terminals TB1-A1 and TB1-A2/F2, respectively, as shown in Figure 3-4. If CW motor rotation is desired (looking from the back of the motor or the shaft end), reverse the motor armature connections at the motor.

For 1365-DAF ONLY, if CCW motor rotation is desired when the Forward/Off/Reverse switch is in the FORWARD position (looking from the back of the motor or the shaft end), connect motor armature leads A1 and A2 to controller terminals TB3-A1 and TB3-A2, respectively. If CW motor rotation is desired (looking from the back of the motor or the shaft end), reverse the motor armature connections at the motor.

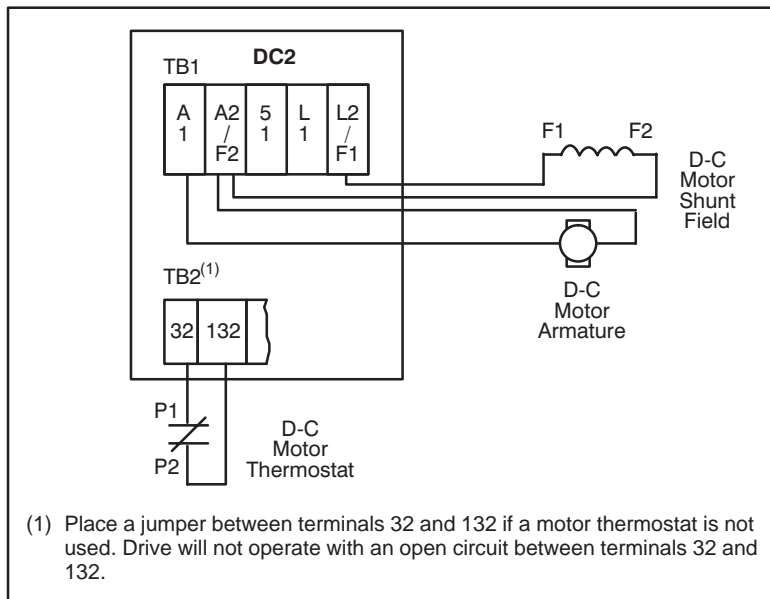

Figure 3-4. Armature, Field and Thermostat (CCW Rotation) Connections.

- Connect the motor shunt field supply (when available) leads F1 and F2 to controller terminals TB1-L2/F1 and A2/F2, respectively. See Figure 3-4.

6. Verify that the field is connected as shown on the motor nameplate or the connection diagram in the terminal box on the motor.
7. Connect the motor thermostat leads P1 and P2 to controller terminal TB2-32 and TB2-132, respectively. See Figure 3-4.

If a motor thermostat is not used, another means of motor overload thermal protection must be used and a jumper must be placed between terminals 132 and 32 on TB2.

Wiring the Start/Stop Circuit

For drives without operator devices on the controller (Catalog 1365-SAN, 1365-PAN, 1365-TAN):

1. Run the Start/Stop pushbutton or normally open contact wiring in the remaining conduit entry separate from the AC and DC power wiring.



ATTENTION: The factory installed jumper must be removed from between controller terminals 51 and L1 if the stop switch is to be wired to these terminals. Failure to observe this precaution could result in bodily injury.



ATTENTION: A maintained closed contact can cause the controller to automatically restart if line input power is removed and then re-applied. Do not use a maintained contact unless the machine is suitably protected. Failure to observe these precautions could result in bodily injury.

2. Use the appropriate tightening torque as listed in Table 3.B for wire connections to input and output terminals.

Table 3.B. Terminal Strip TB2/TB4 Tightening Torques (lbs-in).

TB	Terminals	Torque
TB2	32, 132, 35, 38, 419, 519, 326, 156, 157, 126	4 in-lbs
TB4	6+, 5-	4 in-lbs

3. Connect the Start/Stop pushbutton or normally open contact as shown in Figure 3-5.
4. If Start/Stop control is remote, remove the factory-installed jumper between terminals TB2-35 and TB2-132. See Figure 3-5. With the operator's Start/Stop controls mounted remotely from the controller, the AC fused disconnect or circuit breaker must be mounted in close proximity to the operator controls.



ATTENTION: A start/stop switch that does not include an AC power disconnect function in the Stop position is not recommended for use with the 1365 drive. The 1365 drive does not have an armature loop contactor and a single fault like a thyristor short could cause motor rotation when in the stop mode, if used with a switch that did not disconnect AC power. If a Start/Stop switch without a power disconnect function is used, an AC power disconnect switch **MUST** be mounted next to the operator controls. Failure to observe this precaution could result in bodily injury.

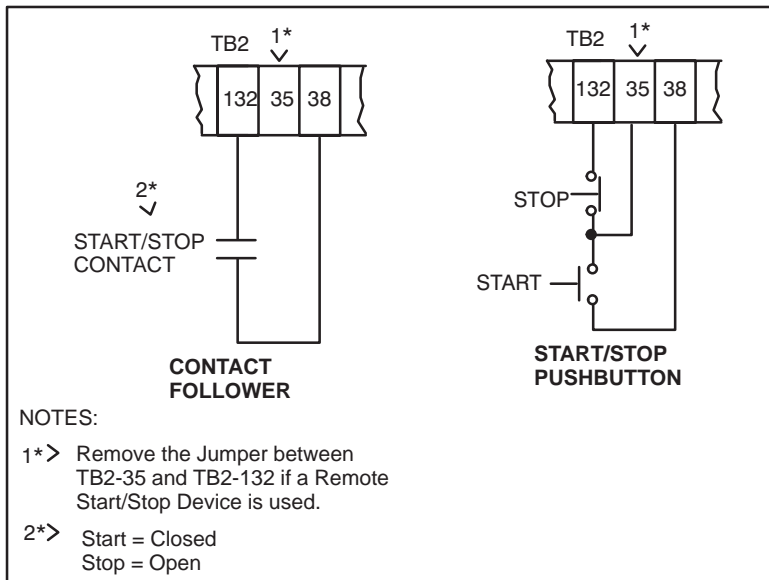

Figure 3-5. Start/Stop Circuit Connection.

Wiring the Run/Jog Circuit

For drives without operator devices on the controller:

1. Run the Run/Jog wiring in conduit separate from the AC and DC power wiring.
2. Use the appropriate tightening torque as listed in Table 3-2 for wire connections to input and output terminals.
3. Wire the Run/Jog switch as indicated in Figure 3-6.

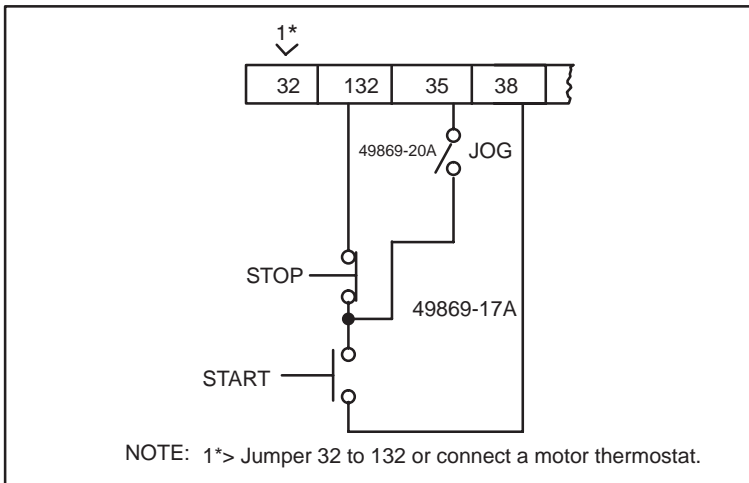

Figure 3-6. Basic Run/Jog Circuit Connections.

Wiring the Reference Signal Potentiometer (1365–SAN, 1365–PAN, 1365–TAN)

For drives without operator devices on the controller:

1. Run all reference wiring in the same conduit as the Start/Stop control wiring separate from the AC and DC power wiring.
2. Use the appropriate tightening torque as listed in Table 3-2 for wire connections to input and output terminals.

3. Use minimum #16 AWG cable that is twisted triple conductor with at least two twists per inch.
4. Connect a 5K ohm, 0.25 watt pot having an insulated operator shaft and knob, such as Available in Catalog 1365–OP or equivalent, as shown in Figure 3-7.



ATTENTION: Because the Reference Potentiometer is connected through the regulator to the Armature Power Circuit, its terminals are at line potential. Use a potentiometer that has plastic shaft to insulate the operator knob from the power circuit. Potentiometer must be rated to withstand Hi–Pot tests at 2000 volts D–C for one minute. Failure to observe this precaution could result in severe bodily injury or loss of life.

Wiring the Process Control and/or Automatic/Manual Devices (if required)

Controller catalog 1365–PAN and 1365–PAF have a high impedance input to interface with process signals. If both manual control (controller responds to a reference potentiometer) and process control (controller responds to an automatic signal) are desired, an Automatic/Manual switch is included in selected controller models (cat 1365–PAF).

1. Use minimum #16 AWG unshielded cable that is twisted double conductor with at least two twists per inch.
2. Use the appropriate tightening torque as listed in Table 3-2 for wire connections to input and output terminals.
3. Wire the process control signal to terminals TB4(6+) and TB4(5–). See Figure 3-7.
4. Wire the process control buffered output TB2-126 to TB2-326. See Figure 3-7.
5. Wire the Automatic/Manual switch, if required, as shown in Figure 3-7.

Wiring the DC Tachometer Speed Feedback Signal



ATTENTION: Because the Tachometer is connected through the regulator to the Armature Power Circuit, its terminals are at line potential. Disconnect all input power to the drive before servicing. Failure to observe this precaution could result in severe bodily injury or loss of life.

All of the controllers, except catalog 1365-DAF or one the user has configured for motor reversing, can utilize a DC tachometer as speed feedback. The tachometer must have a voltage range of 18.5 to 21.0 volts per 1000 RPM or 6.5 to 7.0 volts per 1000 RPM, maximum of 37 volts at maximum speed.

1. Run the two tachometer signal leads in a separate conduit from the motor to the controller.
2. Use minimum #16 AWG unshielded two wire cable that is twisted at least two twists per inch.
3. Use the appropriate tightening torque as listed in Table 3-2 for wire connections to input and output terminals.
4. Connect the DC tachometer so that the tach lead connected to terminal 519 is more positive than the tach lead connected to terminal 419 for the desired direction of rotation. Refer to Figure 3-8.



ATTENTION: Reverse connection will cause the motor to run at maximum uncontrolled speed. The DC tachometer must be connected so that the tach lead connected to terminal 519 is more positive than the negative tach lead connected to terminal 419 for the desired direction of rotation. Failure to observe this precaution could result in bodily injury.

- An isolation transformer must be used between the AC power source and the controller to isolate the controller from the AC power source ground. Each such controller must have its own isolation transformer.

IMPORTANT: Any 1365 controller used in a motor reversing application cannot employ a DC tachometer speed feedback.

NOTE: A DC tachometer used as a speed feedback signal for one controller cannot be used as the speed reference signal for another controller.

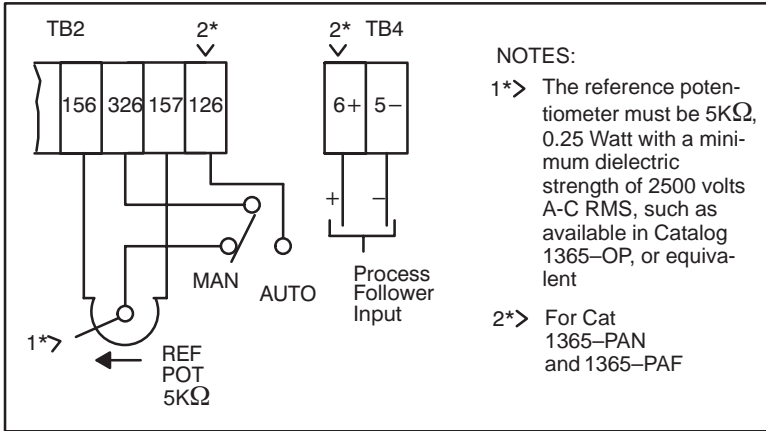

Figure 3-7. Reference Signal Connection.

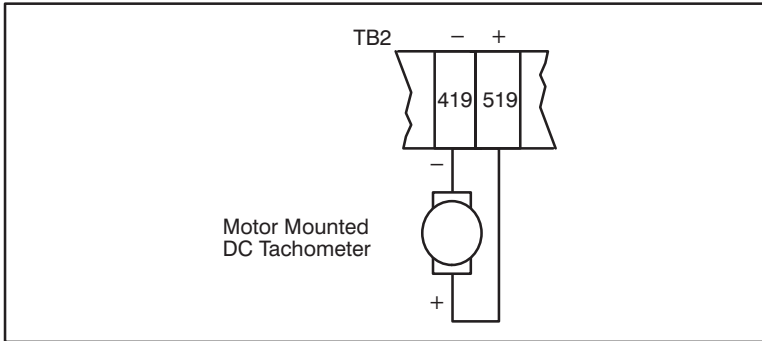

Figure 3-8. DC Tachometer Connection.

Installing Fuse Kits



ATTENTION: Do Not Install modification kits with power applied to the unit. Disconnect and lock out incoming power before attempting a fuse kit installation. Failure to observe this precaution could result in severe bodily injury or loss of life

Each kit is supplied as an assembly with fuse, fuse holder, jumper wire and mounting hardware. The appropriate fuse kit should be selected on the basis of the Drive catalog number as detailed in Table 3.C.

Table 3.C. Fuse Kit Selection

Drive Model Number	Kit Model Number	Fuse Current Rating (Amps)
1365 – SAF 1365 – PAF 1365 – TAF	1365 –Fu2	25
1365 – SAN 1365 – PAN 1365 – TAN	1365 –Fu1	25

For Catalog 1365–SAN/PAN/TAN install the fuse kit as follows:

1. Disconnect and lockout all incoming power to the Bulletin 1365.
2. Use a Phillips head screwdriver to remove the four (4) screws from the faceplate of the Controller.
3. Place the faceplate to the side of the Drive.
4. Use a Phillips screwdriver to remove the two (2) screws from the back panel located at the top of the Drive.
5. Place the fuse kit assembly in place of the blank panel removed in step 4 and then install the fuse kit assembly using the two (2) screws removed in the previous step.

6. Remove the jumper wire between L1 and 51.
7. Using a flathead screwdriver, connect the wire labeled “51” to terminal 51 of the 1365 Drive (Figure 3–9).

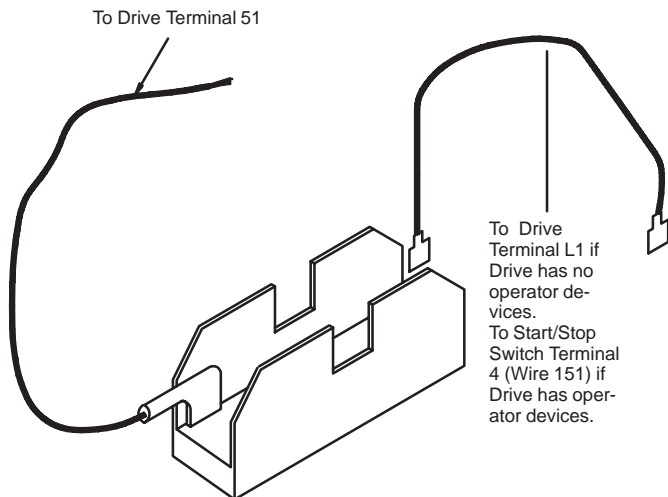

Figure 3-9. Fuse Kit Connections.

8. Using a flathead screwdriver, connect the wire labeled “L1” to terminal L1 of the 1365 Drive.
9. Install the fuse into the holder.
10. Place the faceplate on the Drive and then install the four (4) screws removed in step 2 of this procedure.

For Catalog 1365–SAF/PAF/TAF install the fuse kit as follows:

1. Disconnect and lockout all incoming power to the Bulletin 1365.
2. Use a Phillips head screwdriver to remove the four (4) screws from the faceplate of the Drive.
3. Place the faceplate on the side of the Drive to gain access to the pre-drilled holes located above the grounding bar.

4. Install the fuse holder assembly on the chassis using the two taptite screws provided in the plastic bag with this kit.
5. Remove the existing wire labeled “151” from terminal 51 of the Drive and terminal 4 of the Start/Stop switch.
6. Using a flathead screwdriver, connect the wire labeled “51” to terminal 51 of the Drive.
7. Connect the wire labeled “151” to the bare terminal (terminal 4) of the Start/Stop switch.
8. Install the fuse into the holder.
8. Place the faceplate on the Drive and then install the four (4) screws removed in step 2 of this procedure.

This Page Intentionally Blank

4: Startup and Adjustment of the Drive



ATTENTION: Only qualified electrical personnel familiar with the construction and operation of this equipment and the hazards involved should install, adjust and/or service this equipment. Read and understand this manual in its entirety before proceeding. Failure to observe this precaution could result in severe bodily injury or loss of life.



ATTENTION: This equipment is at line voltage when AC power is connected. Disconnect and lockout all ungrounded conductors of the AC power line. Failure to observe these precautions could result in severe bodily injury or loss of life.

Review all startup and adjustment instructions thoroughly before making any adjustments or applying power to the controller. For your convenience throughout the setup and adjustment procedures, use Figure 4-1 or Figure 4-1A to locate adjustment pots, terminal boards, special selector jumpers and pins. Wiring diagrams are given in Figures 5-1, 5-1A, 5-2 and 5-3.

Position the Controller Jumpers to Fit Application

The controller can operate on either 115V or 230V at multiple horsepower ratings and in various modes. Make sure the circuit jumpers are properly set for the application as described on the following pages. See Figure 4-1, which locates these special selector jumpers and pins.

J4: AC Input Voltage Jumper

Note: This jumper is on all controller models and is factory set for 230 VAC.

1. Verify that J4 is positioned to match AC input line power.
2. If operation is on 115V, relocate J4 to the 115-volt jumper position.

J3: Voltage/Tach Feedback Selection Jumper

Note: This jumper is on all controller models and is factory set for a voltage feedback of 180V.

1. If operation is to be on 115V with voltage feedback, relocate J3 to the 90V jumper position.
2. If a tachometer feedback is to be used, relocate J3 to ‘TACH’ position irrespective of input voltage.

J200: Tachometer Scaling Jumper

Note: This jumper is on all controller models and is factory set for 7 VDC/1000 tachometer scaling (pins 1 and 2).

1. If 20.8 VDC/1000 tachometer scaling is desired, relocate jumper to the 21V position (pins 3 and 4).
2. If the controller is to be used as a voltage regulator, or torque regulator, leave this jumper set for the factory setting of 7 VDC/1000 (pins 1 and 2).

J5: Controller Output Current Jumper

Note: This jumper is on all controller models and is factory set for 2.5 amperes.

1. Select the appropriate controller output current rating from the Table 4.A.
2. Position J5 for the current rating selected in Step 1.

Table 4.A. Controller DC Output Current Rating^①.

Motor HP	Controller Output Current Rating by Input Voltage Rating	
	115 VAC	230 VAC
1/4	2.5	–
1/3	5.0	–
1/2	5.0	2.5
3/4	7.5	5.0
1	10.0	5.0
1-1/2	–	7.5
2	–	10.0

^① Measured with average reading DC ammeter.

J8: Process Control Interface Jumper (Catalog Number 1365-PAN, 1365-PAF)

Note: This jumper is on process control interface controllers (Catalog 1365-PAN, 1365-PAF) and is factory set for a 10V input signal.

1. Select the J8 jumper position based on the process control signal to be used:

Process Control Signal	Jumper Position	Input Impedance
1 - 5 mA	5 mA (Pins 5 and 6)	2K Ω
4 - 20 mA	20 mA (Pins 3 and 4)	450 Ω
10-50 mA	50 mA (Pins 1 and 2)	200 Ω
0 -10 VDC	10V (Pins 4 and 6)	666 Ω

Note: Rotate jumper 90° to select 5, 20, or 50 mA input signals.

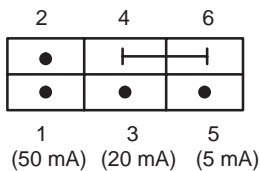
**J201: Minimum Speed Disable**

ATTENTION: The drive is intended to operate at a predetermined minimum speed unless disconnected from the power source. If the application requires zero speed operation with power applied, the user is responsible for assuring safe conditions for operating personnel by providing suitable guards, audible or visual alarms, or other devices. Failure to observe this precaution could result in bodily injury.

Note: A jumper is provided in a plastic bag shipped with the drive.

1. Place the jumper on position J201.
2. Turn MIN SPEED potentiometer fully counter-clockwise to obtain zero minimum speed.

J202: S-Curve Acceleration

Note: A 4.7 μ FD capacitor is provided in a plastic bag shipped with the drive.

1. Attach the capacitor to J202 (pins 1 and 2) if S-Curve acceleration characteristics are desired.

J203: Regulation Mode Jumper(Catalog 1365-SAN, 1365-SAF, 1365-DAF)

Do not move jumper J203.

J401: Rate Range Jumper (Catalog 1365-PAN, 1365-PAF, 1365-TAN, 1365-TAF)

Note: This jumper is factory set for the slow rate range (upper and middle pins). The slow rate range is 3.5 to 40 seconds.

1. Select the fast rate range for better resolution. To select the fast rate range (0.3 to 3.5 seconds), move this jumper to the lower and middle pins.

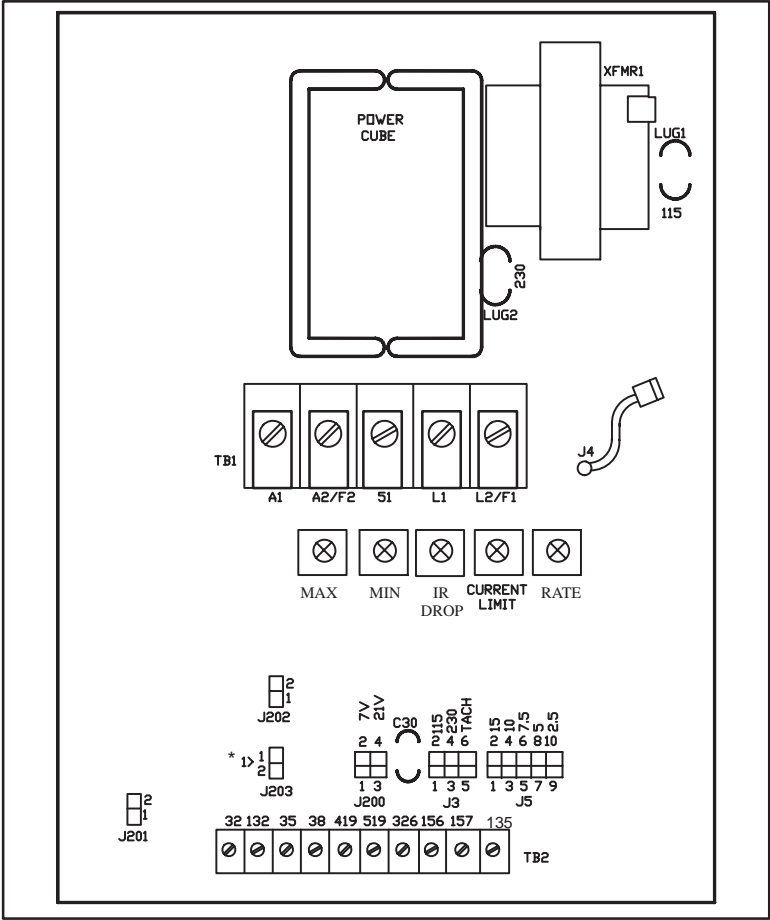

NOTE: *1> DO NOT USE

Figure 4-1. Controller Circuit Board Jumper, Pin and Potentiometer Locations 1365-SAN, 1365-SAF, 1365-DAF.

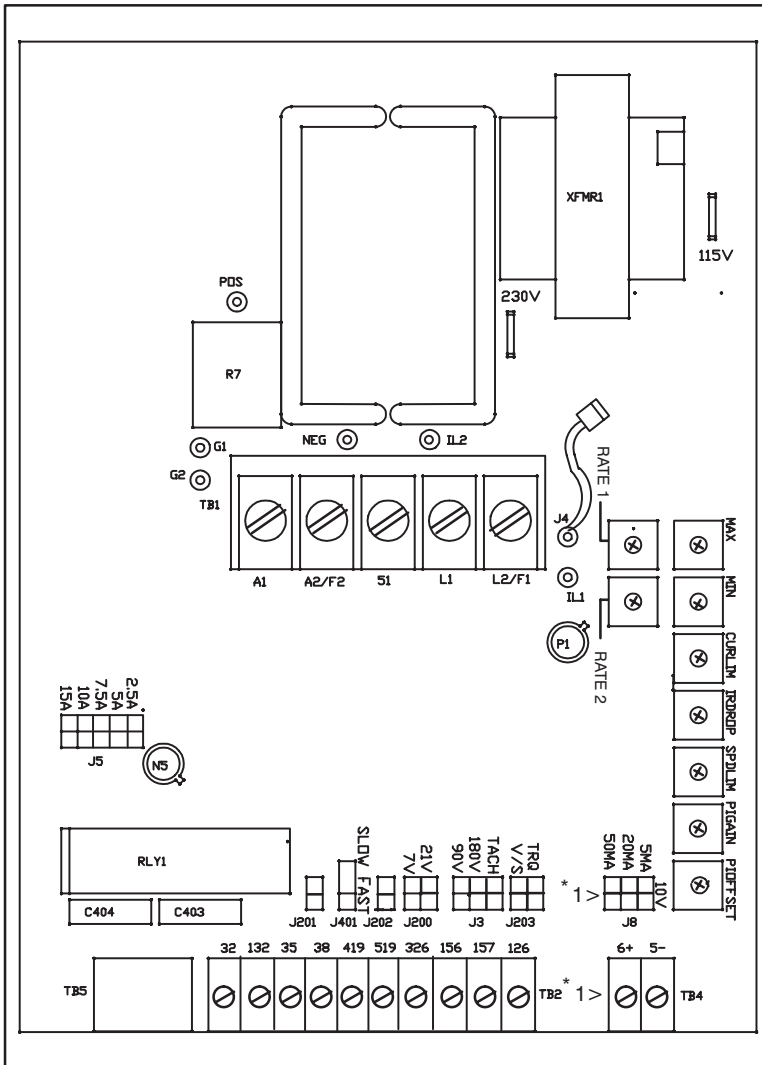

NOTE: *1>Functional on 0-57210-32 Regulator Boards only.

Figure 4-1A. Controller Circuit Board Jumper, Pin and Potentiometers Locations 1365-PAN, 1365-PAF, 1365-TAN, 1365-TAF.

Startup and Adjust the Controller

Note: This procedure covers Speed Control, Process Control, and Torque Control controllers. Therefore, you will find references to “speed, process or torque” when the type of control is important.

1. Verify that the circuit board pots (Figure 4-1) are set as indicated below:

With Speed Control models:

- MAX – fully CCW
- MIN – fully CCW
- IR DROP – fully CCW
- CURRENT LIMIT – 50% of full scale
- RATE – 75% of full scale (A clockwise rotation decreases acceleration time and increases rate).
- PI GAIN (on Process Control models only)
 - fully CCW
- PI BIAS (on Process Control Models only)
 - fully CCW

With Torque Control models:

- MAX – fully CCW
- MIN – fully CCW
- IR DROP – fully CCW
- CURRENT LIMIT – 50% of full scale
- RATE 1 and RATE 2 – 75% of full scale
- PI GAIN (on Process Control models only)
 - fully CCW
- PI BIAS (on Process Control models only)
 - fully CCW
- SPD LIM – fully CCW

2. Set the operator’s speed or torque potentiometer fully CCW.

3. If your controller includes process control, push the Automatic/Manual switch to Manual; otherwise proceed to Step 4.
4. If your controller includes a Forward/Off/Reverse switch, set the switch to the Forward position and proceed to Step 5.



ATTENTION: The remaining steps are made with power on. Exercise extreme caution as hazardous voltage exists. Failure to observe this precaution could result in severe bodily injury or loss of life.

5. Apply A-C input power.
6. Check the direction of motor rotation:
 - Press Start and quickly press Stop to verify correct motor rotation. If the motor shaft doesn't rotate because all potentiometers are set to minimum levels, turn the Speed or Torque potentiometer slightly CW and repeat this start/stop operation.
 - If motor shaft rotation is incorrect, press the Stop switch and wait for the motor to completely stop. Remove AC input power, and reverse the motor armature power leads A1 and A2 at the motor. Reapply AC input power and repeat the direction of rotation check.
 - On applications utilizing DC tachometer speed feedback, when the direction of rotation of the motor is changed, the polarity of the tachometer also changes. The connection of the tachometer must remain 419 negative with respect to 519 for a given direction or rotation.



ATTENTION: The DC tachometer must be connected with the negative lead to terminal 419 and the positive lead to terminal 519 for the desired direction of rotation. Reverse connection will cause the motor to run at maximum uncontrolled speed. Failure to observe this precaution could result in severe bodily injury or loss of life.

7. On controllers employing DC tachometer speed feedback, the following steps may be used to determine the correct direction of rotation and the correct polarity of the DC tachometer speed feedback signal.

- Turn off power.
 - Reconnect unit as a voltage regulator. Make sure J3 jumper is at the appropriate voltage level.
 - Remove the DC tachometer leads from terminals 419 and 519, clearly marking the leads to distinguish one from the other, and connect a DC voltmeter (0 to 60 volt scale) to the DC tachometer leads.
 - Turn on power.
 - With the desired direction of motor rotation established, using the voltmeter that is connected to the DC tachometer signal leads, determine the polarity of the DC tachometer leads. Mark the negative polarity lead 419 and the positive lead 519.
 - Stop the controller, remove AC power, replace the J3 jumper to the tachometer position and connect the DC tachometer leads to the controller as noted above, (-) 419 and (+) 519.
8. Adjust the speed or torque range:



ATTENTION: Do not depend on the minimum position of the speed or torque setting pot to stop the motor. In the minimum position, the controller and motor are still energized. The drive may restart unexpectedly. Turn off and lock out power when performing Startup operations that do not require power to the drive. Failure to observe this precaution could result in bodily injury.

With Speed Control models:

- Use a hand-held tachometer to monitor motor speed; or use a multimeter to measure armature voltage, which is approximately proportional to speed (115-volt control: 90 VDC = 100% speed; 230-volt control: 180 VDC = 100% speed).
- Press the Start button and slowly turn the Speed potentiometer to maximum (fully CW). The motor should run at about 50% of maximum.
- Slowly turn MAX CW until about 80% speed is reached.
- Turn the Speed potentiometer fully CCW.

- Turn MIN CW until the desired minimum speed is reached.
- Since the MIN and MAX potentiometers interact, repeat the Speed Control procedure until the desired maximum and minimum speeds are reached.

With Torque Control models:

Torque control models must only be used when synchronizing this driven machine section with other process machine sections on which there is a drive that consistently and reliably establishes line speed.

- Load the motor with a reasonably constant load over the speed range. Such a system may be a preloaded dancer loop preceding a center driven winder. See Figure 4-2.
- Provide a means of measuring torque, such as measuring armature current. For example, for a 1 HP motor at 180 VDC rated at a armature current of 5 amps and with a base speed of 1750 RPM:

$$\frac{1 \text{ HP} \times 5250}{1750 \text{ RPM}} = 3 \text{ ft-lbs}$$

Therefore, 5 amps equals 3 ft-lbs.

- Re-establish the torque load on the motor and load the motor to maximum torque.
- Press the Start button and slowly turn the Torque potentiometer to maximum (fully CW).
- Slowly turn SPD LIM potentiometer CW until measured torque no longer increases.
- Slowly turn MAX (CW) until the maximum desired torque is reached.
- Turn the torque potentiometer fully CCW.
- Slowly turn MIN CW until the minimum desired torque is reached.
- Since the MIN and MAX potentiometers interact, repeat this Torque Control procedure until the maximum and minimum torques are reached.

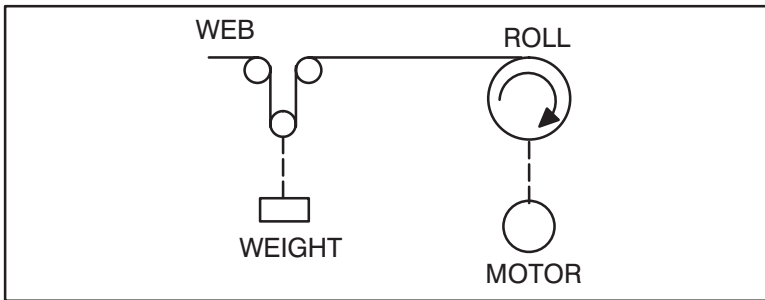

Figure 4-2. Pre-loaded Dancer Loop Preceding Winder.

9. Adjust the current or speed limit:

With Speed Control models:

The maximum DC current output from the controller with CURRENT LIMIT potentiometer set full CW is greater than 150%, possibly 200% maximum, of the J5 armature current setting. If 150% of the J5 armature current is excessive for the application or if stress on the driven equipment must be reduced, turn CURRENT LIMIT in the CCW direction until adequate setting is obtained.

With Torque Control models:

- With minimum load torque (motor disconnected or an empty winder roll without web), turn the Torque potentiometer fully CW and SPD LIM fully CCW.
- Adjust speed limit with SPD LIM for maximum desired motor application speed or 90/180 VDC on the armature.
- Return the Torque potentiometer fully CCW.

10. Adjust the IR Comp:

With Speed Control models only: If the torque demand on the drive motor is relatively uniform, IR drop compensation is not required. Turn IR DROP to zero (CCW).

On models employing D-C tachometer speed feedback, the IR Drop Compensation potentiometer should be set at zero, fully CCW.

If the load torque is changing (i.e., a conveyor that can be empty and then some time later loaded with material), the increased load will cause a speed change. This speed change may be compensated with IR DROP (Figure 4-3). Turn IR DROP slightly CW until this droop is minimized. After adjusting IR drop compensation to minimize speed change with load the maximum and minimum speed settings should be rechecked for proper settings. Note that excessive IR drop compensation can cause motor instability and hunting. A tachometer should be used for better speed regulation.

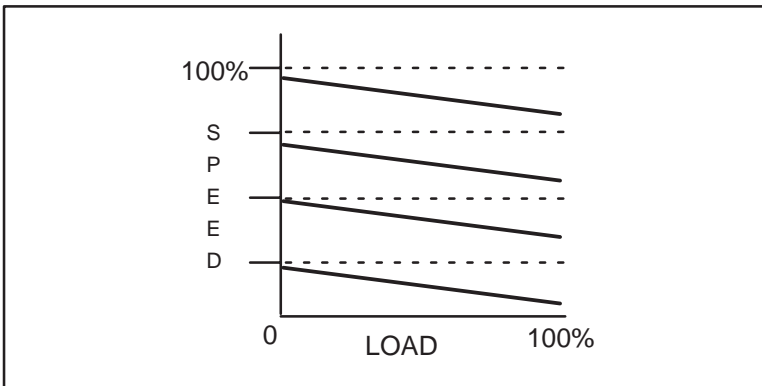

Figure 4-3. Fixed Speed Droop With Load Change.

With Torque Control models:

- IR drop compensation is used to reduce the speed rise above the speed limit threshold due to a loss of load torque.
 - Turn IR DROP to minimize speed rise due to loss of load.
 - Note that excessive IR drop compensation can cause motor instability and hunting. Motors that have a speed drop that varies excessively with operating speed cannot use IR drop compensation. A tachometer should be used for better speed regulation.
11. Press the Stop switch and wait for the motor to completely stop. Remove AC input power.
 12. If you have a Process Control model, proceed to “Setup the Process Interface.”

Setup for Process Interface (For Catalog Number 1365-PAN, 1365-PAF)

Note: The process control input (plus and minus) is buffered from the armature circuit by 300K ohms of resistance. The buffered reference signal output on TB4-126 is positive with input TB4(6+) and TB4(5-). Inputs at TB4(6+) or TB4(5-) may be grounded or left ungrounded as required by the signal source equipment.

1. Disconnect power.
2. Push the Automatic/Manual switch to Auto.



ATTENTION: The process interface signal input terminals TB4(6+) and TB4(5-) are resistively isolated from line potential when AC power is connected. Disconnect and lockout all ungrounded conductors of the AC power line. Failure to observe these precautions could result in severe bodily injury or loss of life.

3. Verify that jumper J8 is properly positioned for your reference signal.
4. Apply AC input power and then press the Start button.



ATTENTION: Adjustment of the process interface bias potentiometer could result in zero speed operation of the controller. The drive is intended to operate at a predetermined minimum speed unless disconnected from the power source. If the application requires zero speed operation without such disconnection, the user is responsible for assuring safe conditions for operating personnel by providing suitable guards, audible or visual alarms, or other devices. Failure to observe this precaution could result in bodily injury.

5. Command minimum reference from your process control unit and adjust PI BIAS to the desired minimum operating speed or torque.

6. Increase the process control reference signal to maximum and adjust PI GAIN to the desired maximum operating speed or torque. It may be necessary to repeat Steps 5 and 6 until proper maximum and minimum speed or torque are attained because these adjustments interact.
7. Press the Stop switch and wait for the motor to completely stop.

Adjust Rate Potentiometer(s)

For Catalog 1365-SAN, 1365-SAF, 1365-DAF

Adjust pot RATE for desired acceleration and deceleration

For Catalog 1365-PAN, 1365-PAF

Adjust RATE 1 and RATE 2 for desired acceleration and deceleration rates.

For Catalog 1365-TAN, 1365-TAF:

1. Set J401 for Fast or Slow rate range:

Note: F (Fast) setting is used for finer resolution at faster rates.

S(Slow) – 3.5 to 40 seconds

F(Fast) – 0.3 to 3.5 seconds

2. Adjust RATE 1 for the desired acceleration rate.
3. Adjust RATE 2 for the desired deceleration rate.

5: Troubleshooting



ATTENTION: Only qualified electrical personnel familiar with the construction and operation of this equipment and the hazards involved should install, adjust, and/or service this equipment. Read and understand this manual in its entirety before proceeding. Failure to observe this precaution could result in severe bodily injury or loss of life.

Should you encounter any difficulty with the operation of your Bulletin 1365 controller, review Table 5.A before performing any troubleshooting on the drive.

The 1365 controller contains all regulator circuitry on one printed circuit board and all power conversion components (thyristors and diodes) in one power cube. If you determine that there has been a malfunction in either of these, replace the drive.



ATTENTION: Servicing energized industrial control equipment can be hazardous. Electrical shock, burns, or unintentional actuation of controlled industrial equipment may cause death or serious injury. Follow the safety related practices of NFPA 70E, Electrical Safety for Employee Workplaces, when working on or near energized equipment. Do not work alone on energized equipment.

Table 5.A. Troubleshooting.

Indication	Possible Cause	Corrective Action
Controller incoming line fuse blows when power is applied to the controller.	Improper incoming AC line wiring or an inadvertent ground in the branch circuit or within the controller enclosure.	Check all incoming AC wires and terminations to and within the controller. Correct any wiring problems and remove any grounds. Replace blown fuse.
	Shorted SCR or malfunction in regulator.	Replace entire controller.

Table 5.A. Troubleshooting. (Continued)

Indication	Possible Cause	Corrective Action
Controller incoming line fuse blows when Start command is given.	Motor armature shorted or grounded.	Repair or replace motor. Replace blown fuse.
	Shorted SCR or malfunction in regulator	Replace entire controller.
	Loose or corroded connection or , incorrect or grounded wiring.	Check that all connections and wiring between the line, controller and motor are correct. Replace blown fuse.
	Sudden, severe application of overload to the motor.	Investigate driven equipment for possible cause and correct. Replace blown fuse.
	Circuit board malfunction.	Replace entire controller.
Motor does not rotate.	Faulty, incorrect or grounded wiring.	Check all external wires and terminations at the controller. Check all wiring within the motor conduit box. Correct wiring.
	Incoming line fuse blown and/or upstream protection devices open.	Investigate upstream equipment for possible cause and correct. Replace blown fuse.
	Open or malfunctioning manual speed or torque potentiometer.	Check all speed or torque pot wiring and the operation of speed or torque potentiometer. Correct.
	With Process Control models; faulty, misconnected or miscalibrated reference signal.	Check automatic reference signal for presence and value. Check for proper polarity. Check jumper for proper calibration. Correct as necessary.
	Start/Stop or Forward/Off/Reverse switch malfunctioning or in the incorrect position.	Investigate and/or replace switch as necessary.
	Motor thermostat open. Open on 32 and 132.	Check for continuity with ohmmeter. Let motor cool if found to be open.

Table 5.A. Troubleshooting. (Continued)

Indication	Possible Cause	Corrective Action
Motor does not rotate. (Continued)	Open circuit between terminals 132 and 35. Either a jumper or normally closed remote stop device must be connected between these two terminals in order for the drive to operate.	Repair switch or insert jumper as required.
	Current feedback jumper set lower than applied motor horsepower.	Recheck and reset as necessary.
Drive will not go to zero speed or torque.	 ATTENTION Do not depend on the minimum position of the speed or torque setting pot to stop the motor. In the minimum position, the controller and motor are still energized. Noise, improper wiring, power line disturbances, malfunctioning components, or mechanical binding may cause the drive to restart unexpectedly. Failure to observe this precaution could result in bodily injury.	Follow the instructions provided in this manual to configure the drive for zero speed (J201: Minimum Speed Disable).
	Controller faulty.	Replace entire controller.
Motor does not reach top speed or deliver rated torque.	Low line voltage.	Check for rated line voltage and correct if not within 10% of the input voltage rating.
	With Process Control models, improperly set maximum speed pots.	Reset maximum speed pots.
	With Process Control models, reference signal producing less than expected maximum value.	Adjust source of automatic reference signal or proper output signal range.
	Overload.	Check for cause of overload and correct.

Table 5.A. Troubleshooting. (Continued)

Indication	Possible Cause	Corrective Action
Motor does not reach top speed or deliver rated torque. (Continued)	Improper position jumper.	Check and reconnect jumper(s) as necessary: <ul style="list-style-type: none"> ● J200: Tach Scaling Jumper ● J3: Controller Output Current Jumper
	Faulty circuit board.	Replace entire controller.
Unstable speed or poor regulation when applied as an armature voltage regulator.	Incorrectly set IR drop compensation pot.	Readjust IR drop compensation pot. Check tachometer.
	Faulty circuit board.	Replace entire controller.
Incorrect speed with tachometer feedback.	Improper feedback selection at J3.	Check J3 for proper feedback selection and reposition as required.
Motor runs at maximum uncontrolled speed with tachometer feedback.	DC tachometer polarity not correct for given direction of motor rotation, 419 negative with respect to 519.	Verify DC tachometer polarity and lead connection.
	Open field for voltage Regulators only.	Measure motor field resistance from drive and connect the voltage field as required.
	No DC tachometer output signal.	Verify tachometer voltage. Verify tachometer coupling.
Motor speed unstable with changing load. (Tach Feedback only)	IR drop compensation pot not set at zero (CCW).	Set IR drop compensation pot to zero (CCW).

Spare Parts

Spare parts are currently not available.

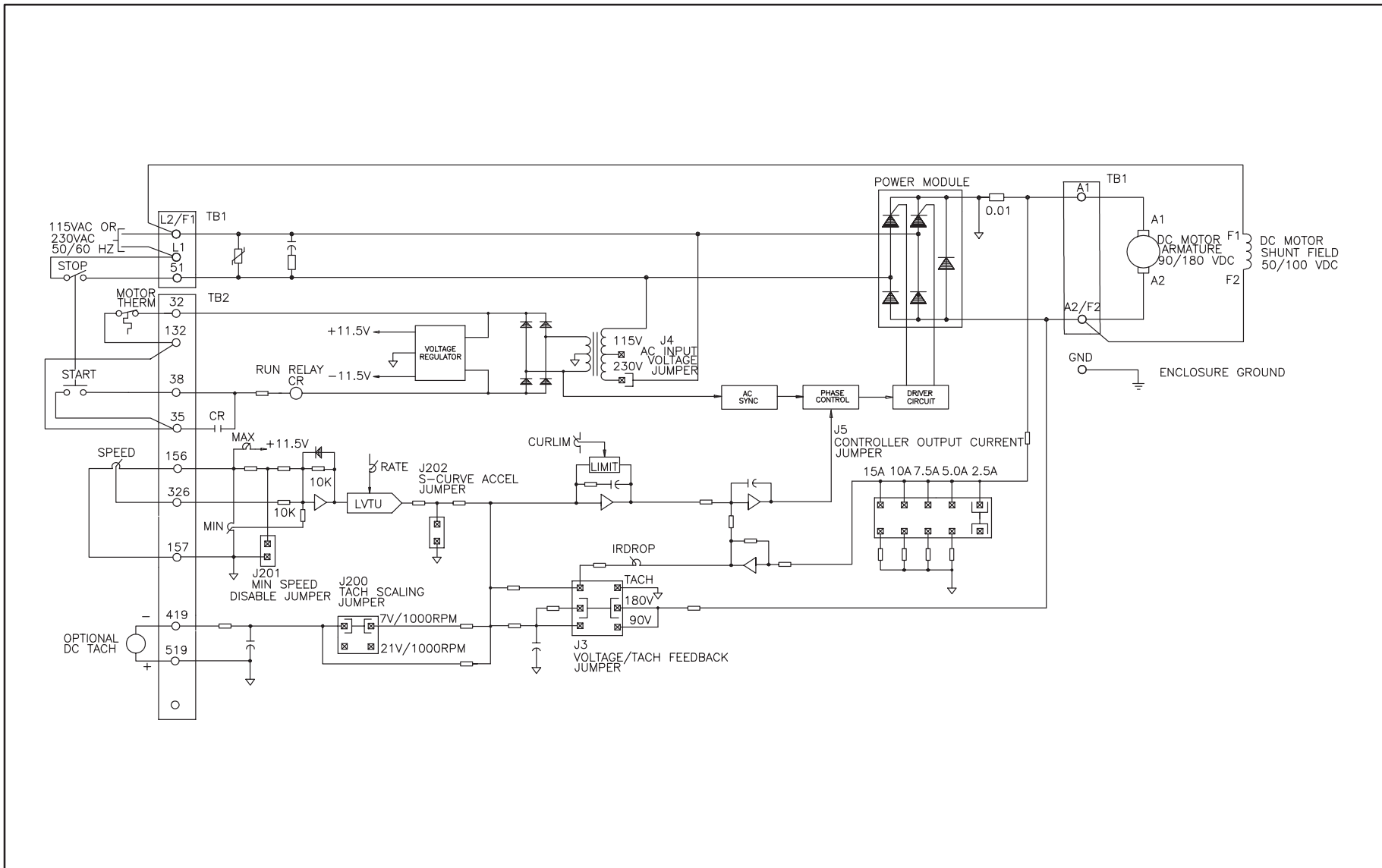

Figure 5-1. Wiring Diagram of Speed Controller (Catalog Number 1365-SAN, 1365-SAF, 1365-DAF).

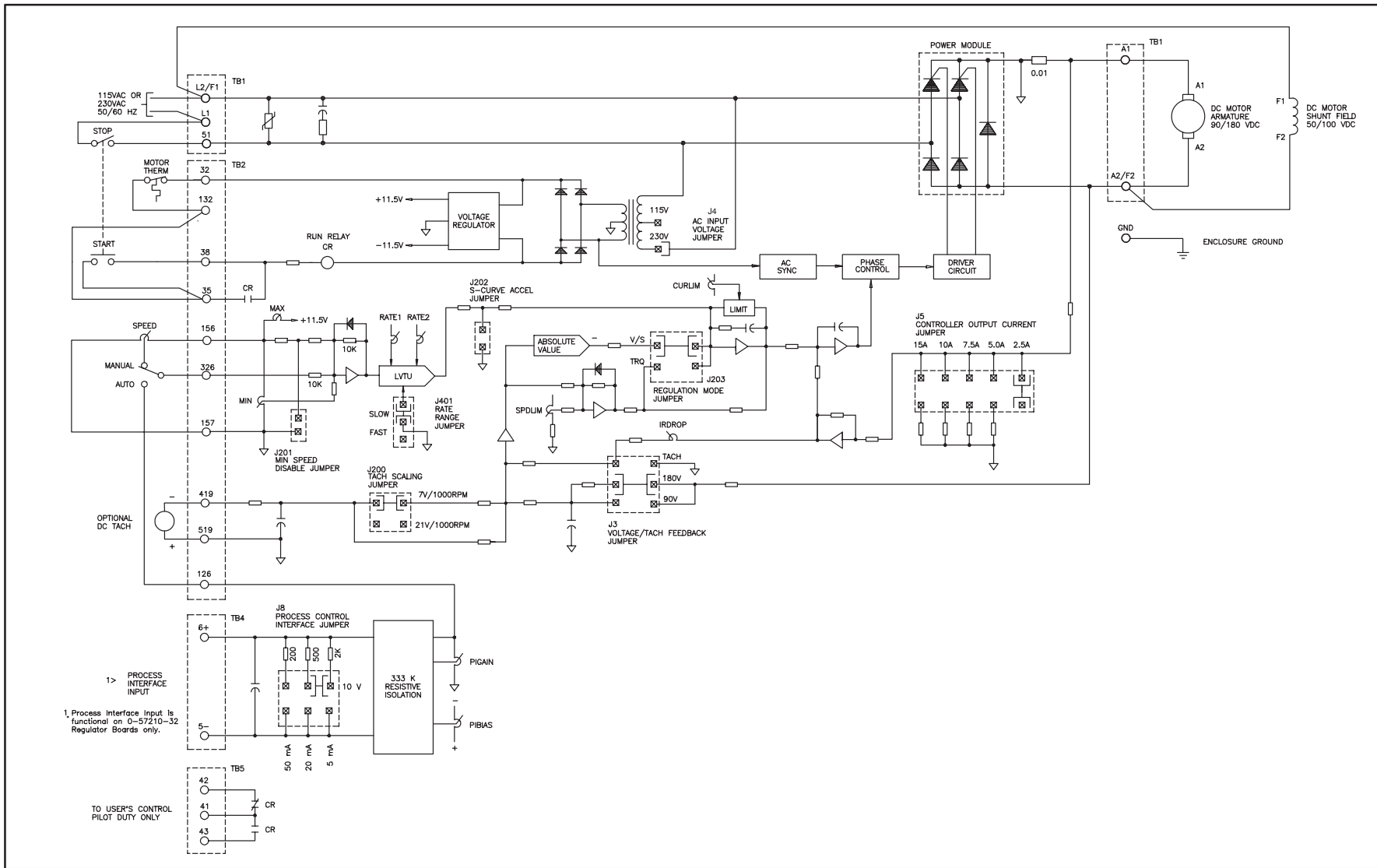

Figure 5-1A. Wiring Diagram of Torque and Process Interface Controller (Catalog 1365-TAN, 1365-TAF, 1365-PAN, 1365-PAF).

Allen-Bradley Spares

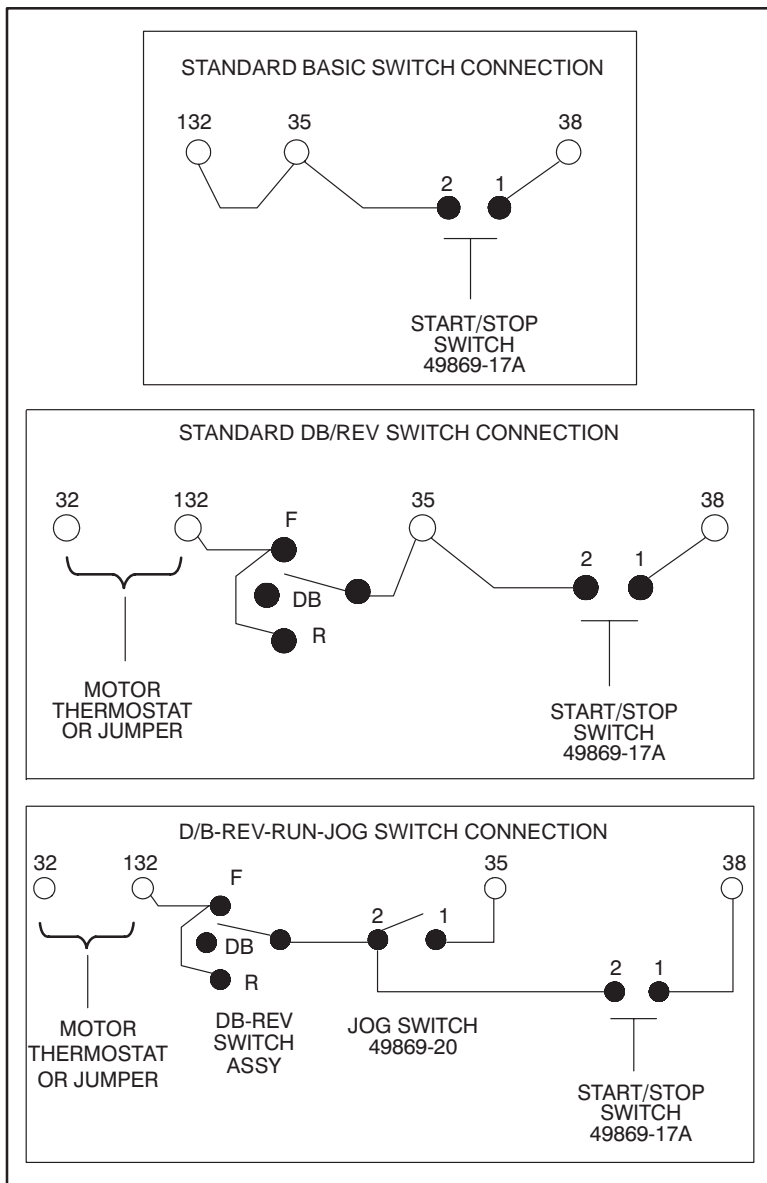

Figure 5-2. Switch Configurations.

DEVICE INTERCONNECTIONS

REVERSING SWITCH
CONTACT POSITION

CONTACT	1 (*)	2 (Z)	3 (&)
A	ON	OFF	ON
B	ON	OFF	ON
C	ON	OFF	ON
D	OFF	ON	OFF

(*) FORWARD POSITION
(Z) DYNAMIC BRAKING (DB) POSITION
(&) REVERSING POSITION

BACK OF REVERSING SWITCH

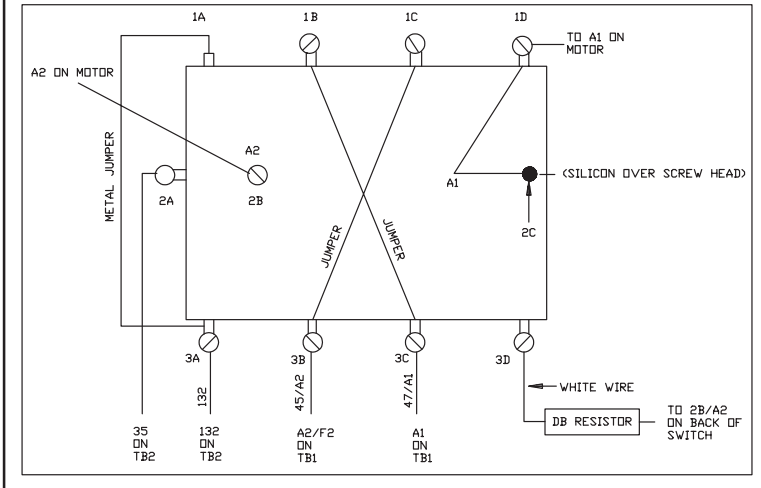

Figure 5-3. Operator Device Interconnections.

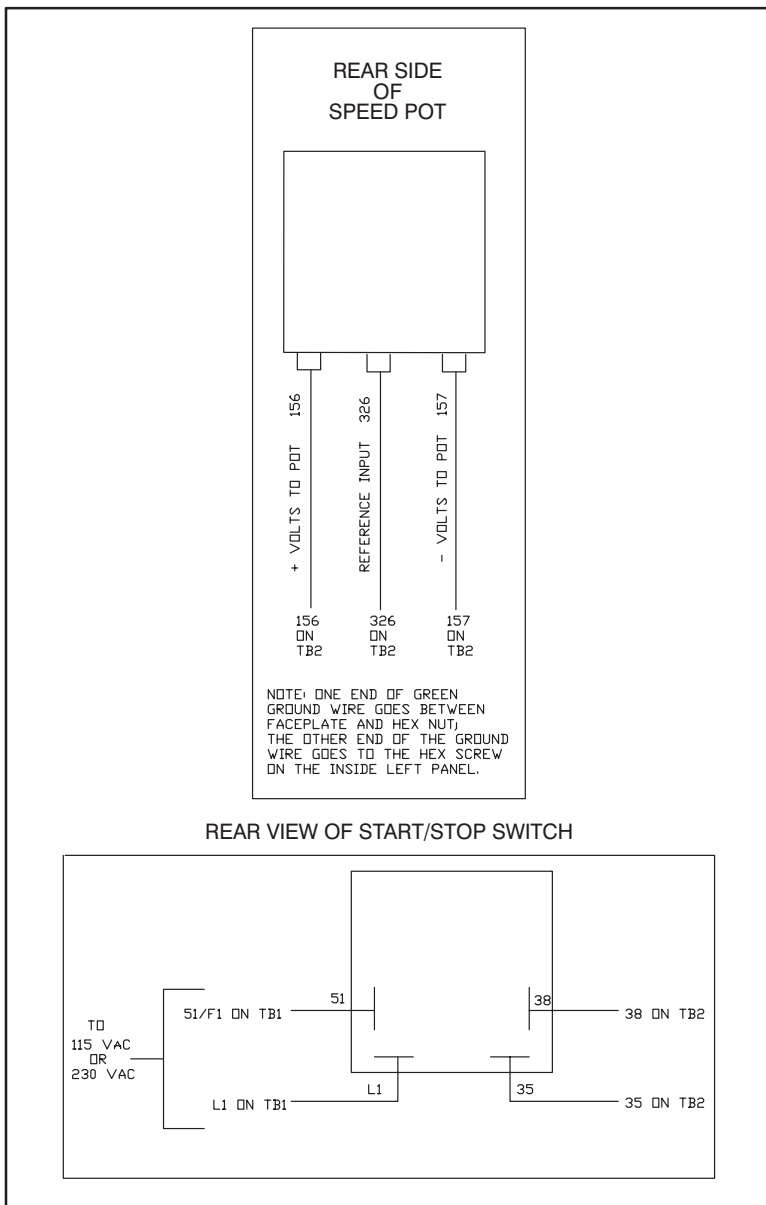

Figure 5-4 Operator Device interconnections. (Continued)



www.rockwellautomation.com

Corporate Headquarters

Rockwell Automation, 777 East Wisconsin Avenue, Suite 1400, Milwaukee, WI, 53202-5302 USA, Tel: (1) 414.212.5200, Fax: (1) 414.212.5201

Headquarters for Allen-Bradley Products, Rockwell Software Products and Global Manufacturing Solutions

Americas: Rockwell Automation, 1201 South Second Street, Milwaukee, WI 53204-2496 USA, Tel: (1) 414.382.2000, Fax: (1) 414.382.4444

Europe: Rockwell Automation SA/NV, Vorstlaan/Boulevard du Souverain 36-BP 3A/B, 1170 Brussels, Belgium, Tel: (32) 2 663 0600, Fax: (32) 2 663 0640

Asia Pacific: Rockwell Automation, 27/F Citicorp Centre, 18 Whitfield Road, Causeway Bay, Hong Kong, Tel: (852) 2887 4788, Fax: (852) 2508 1846

Headquarters for Dodge and Reliance Electric Products

Americas: Rockwell Automation, 6040 Ponders Court, Greenville, SC 29615-4617 USA, Tel: (1) 864.297.4800, Fax: (1) 864.281.2433

Europe: Rockwell Automation, Brühlstraße 22, D-74834 Elztal-Dallau, Germany, Tel: (49) 6261 9410, Fax: (49) 6261 17741

Asia Pacific: Rockwell Automation, 55 Newton Road, #11-01/02 Revenue House, Singapore 307987, Tel: (65) 351 6723, Fax: (65) 355 1733

U.S. Allen-Bradley Drives Technical Support

Tel: (1) 262.512.8176, Fax: (1) 262.512.2222, Email: support@drives.ra.rockwell.com, Online: www.ab.com/support/abdrives

Publication 1365-5.0 – August, 1994

P/N 74101-457-01 (A)

Copyright © 2001 Rockwell Automation. All rights reserved. Printed in USA.