



1391B-ES AC Servo Controller A Quad B Board

Instructions

Introduction

This publication provides the information needed to properly install (if required), wire and use the A Quad B function with the 1391B-ES AC Servo Controller. The material presented supplements the Bulletin 1391B-ES Instruction Manual.

Description

The A Quad B Board (see Figure 1) changes the resolver signal from a 1326AB or AD motor into an encoder signal for use by a position controller.

Figure 1
A Quad B Board Location

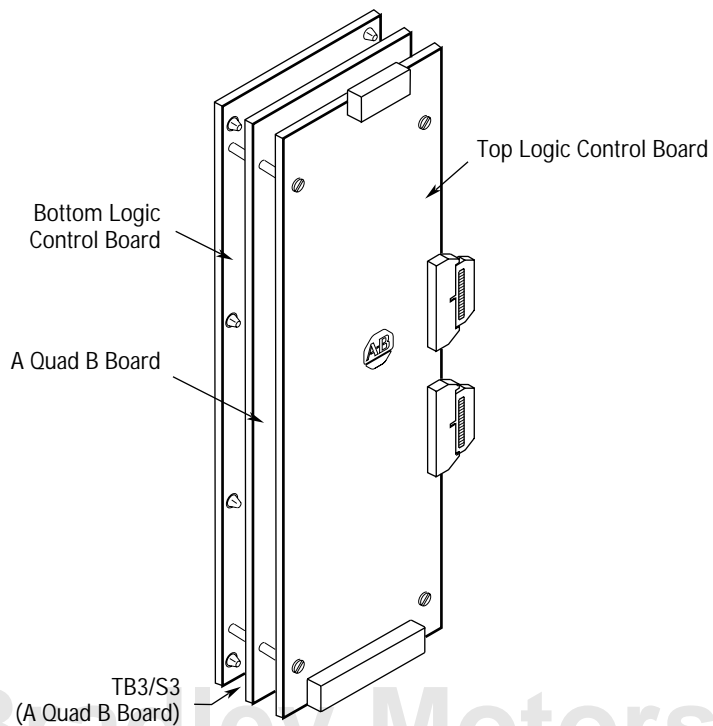

Installation



ATTENTION: To avoid an electrical shock hazard assure that all power to the controller has been removed prior to performing the following procedure.



ATTENTION: The controller contains ESD (Electrostatic Discharge) sensitive parts and assemblies. Static control precautions are required when installing, testing, servicing or repairing this assembly. Component damage may result if ESD control procedures are not followed. If you are not familiar with static control procedures, reference A-B publication 8000-4.5.2, *Guarding Against Electrostatic Damage* or any other applicable ESD protection handbook.

Perform the following installation procedure only if the A Quad B Option Kit was received.

Components supplied:

(1) A Quad B Circuit Board and (1) plastic insulator

1. Ensure that all power has been removed to the controller.
2. Remove the front cover of the controller. Disconnect the ribbon cable leading from the chassis to the top Logic Control Board of the controller.
3. Remove the Logic Control Boards (2) by carefully squeezing the standoffs between the bottom board and chassis.
4. Remove the ribbon cable connecting the top and bottom Logic Control Boards.
5. Separate the two boards by unscrewing the standoffs. The standoffs should remain in the bottom board.
6. Position the A Quad B Board with the foil side up. Lay the supplied insulator on the foil side of the A Quad B Board.
7. Carefully snap the top Logic Control Board to the A Quad B Board. The foil sides of the boards must face one another. Assure that the insulator is still in place.
8. Align the pins on the A Quad B Board with the socket on the bottom Logic Control Board. Snap the boards together. Reconnect the ribbon cable previously removed in step 4.
9. Mount the completed board assembly back on the chassis.
10. Reconnect the ribbon cable previously removed in step 2.

Wiring

Figure 2 provides interconnect information between the position controller and TB3 on the A Quad B Board. Refer to Figure 1 for board location.



ATTENTION: To guard against possible damage to the A Quad B Board, assure that wiring between TB3 and the position controller is correct. Refer to Figure 2.

Figure 2
A Quad B Board Wiring

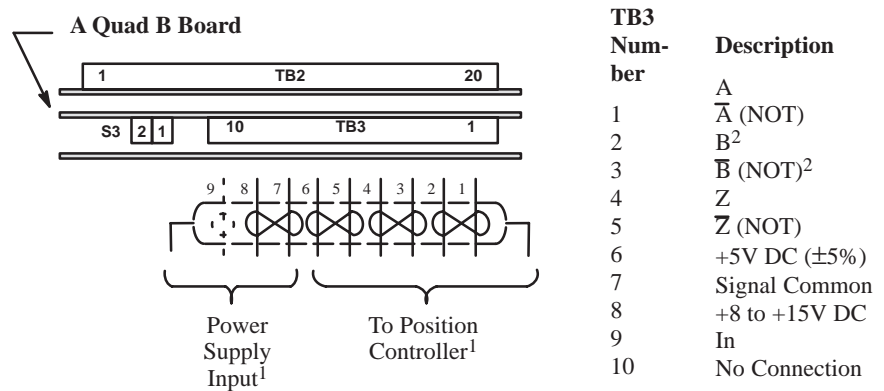

Important: Note terminal orientation prior to wiring.

- ¹ Recommended Wire – Belden #9728 or equivalent. Maximum distance between the A Quad B Board and the position controller is 40 feet (12.2 meters) using a 5 volt signal. For distances up to 300 feet (91 meters), 18 gauge wire and an 8 to 15V DC power supply must be used.
- ² For proper operation when interconnecting to IMC products, the B and \bar{B} (NOT) signals must be reversed.
When interfacing to IMC 121 or 123 controllers, use the 1391-CAQB cable.

Setup and Operation

The A Quad B option operates in the same manner as the Allen-Bradley 845H Line Driver Encoder (26LS31 line driver output). The option requires either a regulated +5V DC at terminal 7 or an unregulated +8 to +15V DC input at terminal 9 (board draws 125mA maximum). The pulse train output is selectable to 256, 512, 1024 or 2048 lines per revolution via the Encoder Output switch, S3 (see Figure 3). S3 selects the line count that will be output from the A Quad B Board.



ATTENTION: Incorrect setting of S3 can cause erratic and/or improper machine motion which may result in personal injury or equipment damage. Assure that switch S3 has been properly set as shown in Figure 3.

Figure 3
A Quad B Board Switch (S3) Settings

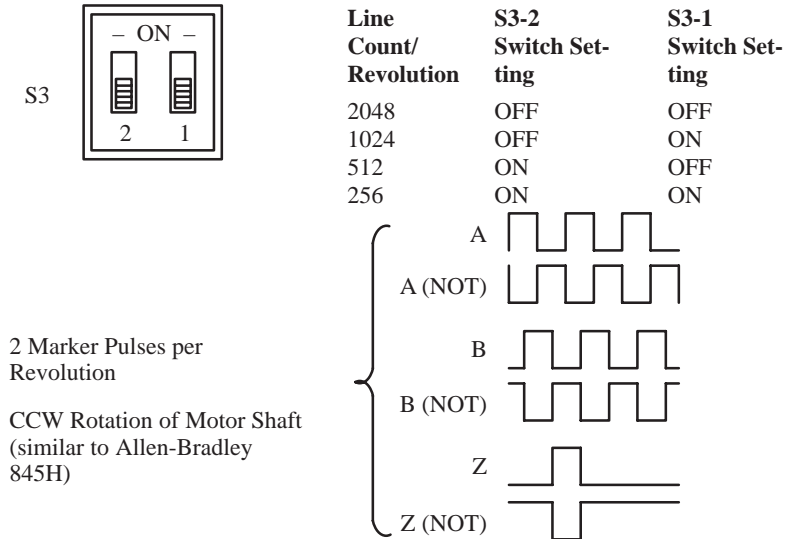

When using the A Quad B option with Allen-Bradley IMC motion controllers, the AMP parameters will be set according to the line count selected. In general, one parameter must be justified when using this device. The normal line counts per cycle of the encoder must be divided by two since the controller will see two markers per cycle.

Example (using an IMC 120 Controller)

With switch S3 set to 1024 lines per revolution (S3-2 OFF, S3-1 ON), the lines per cycle of the position feedback device (located in the Feedback Parameters File) must be 2048.

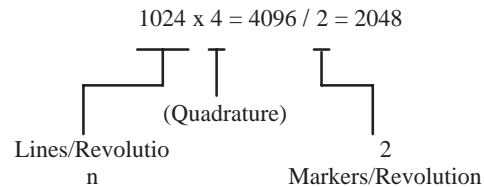

A subsidiary of Rockwell International, one of the world's largest technology companies, Allen-Bradley meets today's automation challenges with over 85 years of practical plant floor experience. More than 12,000 employees throughout the world design, manufacture and apply a wide range of control and automation products and supporting services to help our customers continuously improve quality, productivity and time to market. These products and services not only control individual machines, but also integrate the manufacturing process while providing access to vital plant floor data that can be used to support decision-making throughout the enterprise.

With offices in major cities worldwide.

WORLD HEADQUARTERS
Allen-Bradley
1201 South Second Street
Milwaukee, WI 53204
USA
Tel: (1) 414 382-2000
Telex: 43 11 016
Fax: (1) 414 382-4444

EUROPE/MIDDLE EAST/AFRICA HEADQUARTERS
Allen-Bradley Europe B.V.
Amsterdamseweg 15
1422 AC Uithoorn
The Netherlands
Tel: (31) 2975/43500
Telex: (844) 18042
Fax: (31) 2975/60222

ASIA/PACIFIC HEADQUARTERS
Allen-Bradley (Hong Kong) Limited
Room 1006, Block B, Sea View Estate
2-8 Watson Road
Hong Kong
Tel: (852) 887-4788
Telex: (780) 64347
Fax: (852) 510-9436

CANADA HEADQUARTERS
Allen-Bradley Canada Limited
135 Dundas Street
Cambridge, Ontario N1R 5X1
Canada
Tel: (1) 519 623-1810
Fax: (1) 519 623-8930

LATIN AMERICA HEADQUARTERS
Allen-Bradley
1201 South Second Street
Milwaukee, WI 53204
USA
Tel: (1) 414 382-2000
Telex: 43 11 016
Fax: (1) 414 382-2400