

Introduction

Chapter 1

Manual Objectives 1-1
 1391 Series D 1-1
 General Precautions 1-2
 Controller Description 1-2
 Standard Features 1-3
 Options/Modifications 1-4
 Controller Layout 1-4

Specifications

Chapter 2

Chapter Objectives 2-1
 Controller Specifications 2-1
 Environmental Specifications 2-2
 Controller Power Dissipation 2-2
 Transformer Power Dissipation 2-2

Receiving, Unpacking and Inspection

Chapter 3

Chapter Objectives 3-1
 Receiving 3-1
 Unpacking 3-1
 Inspection 3-1
 Storing 3-1

Description of Operation

Chapter 4

Chapter Objectives 4-1
 General 4-1
 300V DC Power Bus Supply 4-1
 PWM Operation 4-1
 Shunt Regulator Operation 4-2
 Logic Power Supply 4-3
 Logic Control Boards 4-3
 Fault Monitoring and Detection 4-4
 Isolated Current Sensing 4-5
 Integral Circuit Breaker 4-5
 Line/DB Contactor 4-5
 Power Driver Board 4-5
 A Quad B Board 4-5
 Starting and Stopping 4-5
 Power-Up/Down Sequence 4-7

Inputs, Outputs and Adjustments	Chapter 5	
	Chapter Objectives	5-1
	Inputs/Outputs	5-1
	Potentiometer Adjustments	5-6
	Switch Settings	5-7
Installation	Chapter 6	
	Chapter Objectives	6-1
	Mounting	6-1
	Wiring Recommendations	6-2
	Wiring	6-4
Start-Up	Chapter 7	
	Chapter Objectives	7-1
	Start-Up Procedure	7-1
The 1326AB AC Servomotor	Chapter 8	
	Chapter Objectives	8-1
	Introduction	8-1
	Motor Options/Accessories	8-3
Transformers and Shunt Regulators	Chapter 9	
	Chapter Objectives	9-1
	1391 Transformers	9-1
	Shunt Regulator Operation	9-4
	Shunt Regulator Installation	9-6
Troubleshooting	Chapter 10	
	Chapter Objectives	10-1
	System Troubleshooting	10-1
	Test Point Descriptions	10-5
Dimensions	Appendix A	
Interconnect Drawings	Appendix B	
Cable Information	Appendix C	
Controller Options	Appendix D	

Introduction

Manual Objectives

This manual is meant to guide the interface, installation, setup and troubleshooting of a 1391B-ES AC Servo Controller. The contents are arranged in order from a general description of the controller to troubleshooting and maintenance. To ensure successful installation and operation, the material presented must be thoroughly read and understood before proceeding. Particular attention must be directed to the Attention and Important statements contained within.

Important Information about this Manual

This manual has been prepared primarily to support this product in a single controller application. It is a standard document that is intended to help the user understand the individual operating characteristics and limitations of this equipment including hazards associated with installation, setup and maintenance procedures. Note the following points:

- n This equipment has been designed to meet the requirements of a component controller in an integrated controller system.
- n While the potential hazards associated with the controller remain the same when used in a system environment, it must be noted that special considerations are to be given to characteristics of other peripheral solid-state control equipment and the cumulative impact on safety.
- n Manufacturers and engineering groups responsible for specification or design of electrical control equipment must refer to applicable industry standards and codes for specific safety guidelines and interface requirements.
- n In the actual factory environment, the user is responsible to ensure compliance with applicable machine and operator safety codes or regulations which are beyond the scope and purpose of this document.

1391 Series D

Allen-Bradley's commitment to continuing product improvement has led to the introduction of the **1391 Series D Servo Controller**. The catalog number string for the Series D will be unchanged, however, the controller nameplate will appear as follows:

CAT 1391B-xxx

SER D

This new series incorporates a re-designed Power Driver Board that increases manufacturing quality and provides a platform for new versions of the 1391 that are now in development.

This enhancement is totally transparent to the user of this product. The Control Board and all other components of the controller remain the same.

General Precautions

In addition to the precautions listed throughout this manual, the following statements which are general to the controller must be read and understood.



ATTENTION: Only personnel familiar with the 1391B-ES Servo Controller and associated machinery should plan or implement the installation, start-up and subsequent maintenance of the controller. Failure to comply may result in personal injury and/or equipment damage.



ATTENTION: An incorrectly applied or installed controller can result in component damage or a reduction in product life. Wiring or application errors, such as, undersizing the motor, incorrect or inadequate AC supply, or excessive ambient temperatures may result in malfunction of the controller.



ATTENTION: This controller contains ESD (Electrostatic Discharge) sensitive parts and assemblies. Static control precautions are required when installing, testing, servicing or repairing this assembly. Component damage may result if ESD control procedures are not followed. If you are not familiar with static control procedures, reference Allen-Bradley publication 8000-4.5.2, Guarding Against Electrostatic Damage or any other applicable ESD Protection Handbook.

Important: In order to maintain UL listing on Allen-Bradley 1391B-ES Servo Controllers, the user must provide power from a 1391 Isolation Transformer. Use of any other transformer voids the UL listing.

The user is responsible for providing motor overload protection in accordance with the National Electrical Code (NEC), and any other local codes that may apply.

Controller Description

The 1391B-ES Pulse Width Modulated Servo Controller is a dedicated, single axis, AC servo controller. It has been packaged to require a minimum amount of panel space while containing, as standard, a number of features required by the machine tool and automated equipment industries.

The 1391B-ES allows the user to achieve higher operating speeds with purchased motors or from motors already in use. Depending on the motor, the 1391B-ES can produce up to 30% more speed without loss of torque. This can help achieve greater precision, a finer finished product and increased production from existing machinery.

The 1391B-ES is generally used with a computer aided, closed loop positioning system to control the position and linear or rotary motion of various machine members on an automated machine.

All components are mounted in an open framed package with a slide-on front cover. The controller is intended to be panel mounted in an enclosure and ventilated with filtered and/or cooled air. An internal fan is included to circulate air over the power heat sink.

The 1391B-ES converts a three-phase, 50/60 Hz input, to a variable AC voltage with controlled phase, amplitude and frequency. The output which is proportional to a user supplied analog command, regulates the speed and/or current (torque) of a 1326 permanent magnet AC servomotor. The controller is available in ratings of 15, 22.5 and 45A RMS with all package sizes being identical. A 1391 Transformer, 1326 AC Servomotor and 1326 Cables complete the servo system.

Standard Features

The 1391B-ES contains a number of standard features required in a typical automated machine servo system.

- Input protected against transient voltage.
- A power line/DB contactor which opens the AC line to the controller and inserts a shunt regulator resistor across the DC bus whenever the contactor is de-energized.
- An integral circuit breaker which will open all three AC line leads in the event of a short circuit condition in the power circuitry.
- A standard 300V DC power bus supply that includes an integral shunt regulator.
- A shunt regulator resistor to dissipate the energy generated by the motor during regenerative braking.
- Velocity loop components to compensate for a system inertia range between 0.03 to 1.0 lb.-in.-s².
- User selectable mechanical resonance filtering.
- Patented current control implementation.
- Acceleration or torque feedforward differential input.
- DIP switch configurable.
- Logic Boards that can be quickly removed and easily interchanged for troubleshooting and diagnostics.
- Three controller ratings that are in the same physical package and have identical mounting dimensions.
- True vector control.
- Up to 300 feet (91.4 meters) between controller and motor.

Options/Modifications

The 1391B-ES contains most functions needed in a servo system.

The following are selectable at the user's option:

- Contactor Auxiliary Switch
Two N.O. contacts are mounted on the main power contactor and wired to the power terminal block. These contacts can be used in a motor brake control circuit or as an indicator that the contactor has closed.
- Current or Torque Amplifier Operation
When the velocity loop is being closed as part of the position control system, the controller can be configured to operate as a current or torque amplifier by use of the S2 switch settings.
- External Shunt Regulator Resistor
On 15 and 22.5A controllers an internal power resistor that is part of the DC bus voltage shunt regulator can dissipate 162 watts continuous power. Some applications such as an overhauling load have excessive regenerative energy to dissipate. For these applications, an external shunt regulator resistor rated at 386 watts continuous can be supplied for user mounting on 22.5A controllers. This is selectable by removing the jumper on TB5 and using an external resistor. The shunt has integral fusing accessible from the outside of 15 and 22.5A controllers. The 45A controller has an externally mounted resistor and fuse.
Important: An external shunt regulator resistor is included as standard equipment on 45A units. An additional unit is not required.
- Tach Output
A voltage equal to 2.0V DC/1000 RPM is available at TB2. 1.2V DC/1000 RPM on units set for 6000 RPM operation.
- Torque or Current Monitor
A voltage equal to 3.0V DC=100% scaled current is available at TB2.
- Anti-Backlash
Provisions to use the 1388 Anti-Backlash module are provided.

Controller Layout

Figure 1.1 provides an exterior view of the 1391B-ES AC Servo Controller, showing accessibility of various components.

Figure 1.1
1391B-ES AC Servo Controller

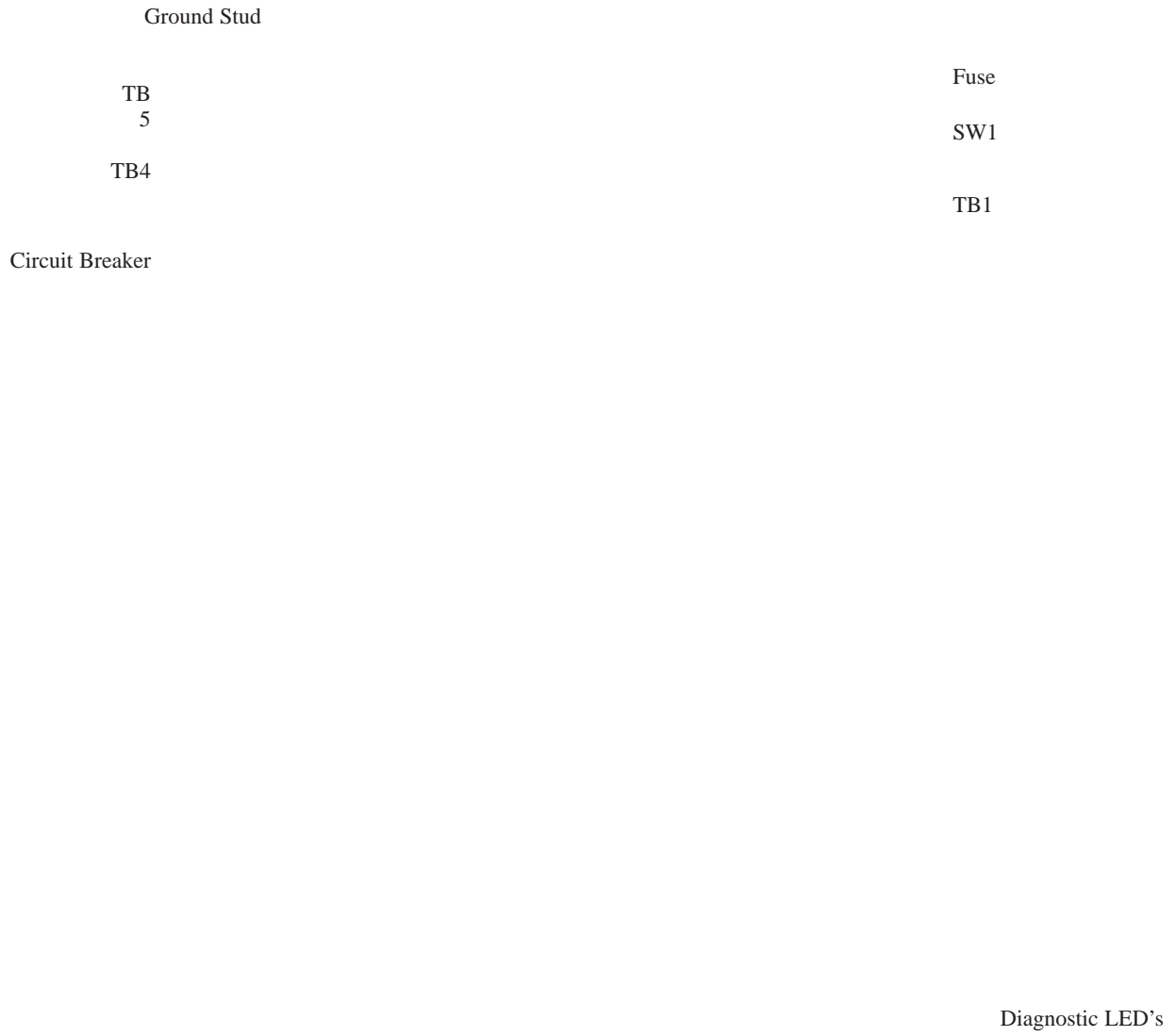

End of Chapter

Specifications

Chapter Objectives

Chapter two contains the electrical and environmental specifications for the 1391B-ES. Dimensions are provided in Appendix A.

Controller Specifications

The general specifications of the 1391B-ES are provided in the listing below. The specifications are divided when necessary for the various controller ratings.

<u>Specific Controller Ratings</u>	<u>1391B-ESAA15</u>	<u>1391B-ESAA22</u>	<u>1391B-ESAA45</u>
Nominal Bus Output Voltage	300V DC	300V DC	300V DC
Continuous Current (RMS)	15A	22.5A	45A
Peak Current (RMS)	30A	45A	90A
Continuous Power Output	5.0 kW	7.5 kW	15.0 kW
Peak Power Output	10.0 kW	15.0 kW	30.0 kW
Input Circuit Breaker Rating	17A RMS	26A RMS	38A RMS
Circuit Breaker Interrupt Rating (Symmetrical Amperes)	1300A	1300A	1300A
Unit Weight in lbs. (kg)	22 (9.97)	28 (12.69)	34 (15.40)

All Controller Ratings

Static Gain (A/RMS)	1.5 x Rated Motor Current / rpm
Form Factor	1.03 or less
Peak Current Limit Adjust rating of	20 to 300% of Rated Motor Current (to 2 times continuous drive, maximum)
Controller Efficiency (Minimum at Rated Load)	85%
Modulation Frequency	2500 Hz \pm 10%
Drift (Referred to Tach)	0.07 rpm /Degrees C. Maximum
Ambient Temperature	0 to 60° C (32 to 140° F)
Storage Temperature	0 to 65° C (32 to 149° F)
Input Voltage (from Transformer) Hz \pm 3 Hz	Power: 230V AC, Three-Phase, 50/60 Control: 36V AC CT, Single-Phase
Relative Humidity	5 to 95% Non-Condensing
Deadband	Zero
Altitude	1000 meters (3300 feet)
Integral Fan Output	50 CFM (Unloaded)
Max. RMS Short Circuit Current (Symmetrical Amperes)	1300A
Transformer Input Tolerance	+10%, -15%

Specifications are for reference only and are subject to change without notice.

Environmental Specifications

The 1391B-ES must be mounted in an enclosure that is clean, dry and ventilated by filtered or cooled air. Enclosures vented with ambient air must have appropriate filtering to protect against contamination caused by oils, coolants, dust, condensation etc. The ambient air temperature must be kept between 0 to 60° C (32 to 140° F) and the humidity between 5 and 95%, non-condensing.

The 1391B-ES is equipped with an integral cooling fan. The general flow of air through the unit must be maintained by following the recommended spacing guidelines found in Chapter 6. The 1391B-ES can operate at elevations to 3300 feet (1000 meters) without derating, however, the current rating must be derated by 3% for each additional 1000 feet (305 meters) up to 10,000 feet (3050 meters). Consult with your local Allen-Bradley Sales Representative prior to operation over 10,000 feet (3050 meters).

Controller Power Dissipation

The 1391B-ES dissipation characteristics are approximated in Table 2.A.

Table 2.A
Controller Power Dissipation

Rated Power Output (%)	1391B-ESAA (watts)	1391B-ESAA (watts)	1391B-ESAA (watts)
20	38	55	104
40	76	110	208
60	114	165	312
80	152	220	416
100	190	275	520

Transformer Power Dissipation

The power dissipation characteristics of the 1391 Isolation Transformer are shown in Table 2.B.

Table 2.B
1391 Isolation Transformer Power Dissipation

Rated Power Output (%)	1.5kV A (watts)	3.5kV A (watts)	5.0kV A (watts)	10.0kV A (watts)	12.5kV A (watts)	15.0kV A (watts)
20	13	35	50	100	125	150
40	25	70	100	200	250	300
60	38	105	150	300	375	450
80	50	140	200	400	500	600
100	60	175	250	500	625	750

Important: Power Dissipation figures shown are for use in calculating cumulative system heat dissipation to ensure ambient temperature inside enclosure does not exceed 60° C (140° F).

AB Spares

Receiving, Unpacking and Inspection

Chapter Objectives

Chapter 3 provides the information needed to unpack, properly inspect and if necessary, store the 1391B-ES and related equipment. The section entitled *Inspection* provides a complete explanation of the 1391B-ES catalog numbering system.

Receiving

It is the responsibility of the user to thoroughly inspect the equipment before accepting the shipment from the freight company. Check the item(s) received against the purchase order. If any items are obviously damaged, it is the responsibility of the user not to accept delivery until the freight agent has noted the damage on the freight bill. Should any concealed damage be found during unpacking, it is again the responsibility of the user to notify the freight agent. The shipping container must be left intact and the freight agent should be requested to make a visual inspection of the equipment.

Unpacking

Remove all packing material, wedges, or braces from within and around the controller. Remove all packing material from the cooling fans, heat sink etc.

Important: Before the installation and start-up of the controller, a general inspection of mechanical integrity (i.e. loose parts, wires, connections, packing materials, etc.) must be made.

Inspection

After unpacking, check the item(s) nameplate catalog number against the purchase order. An explanation of the catalog numbering system is included on the following pages as an aid for nameplate interpretation.

Storing

The controller should remain in its shipping container prior to installation. If the equipment is not to be used for a period of time, it must be stored according to the following instructions:

- Store in a clean, dry location.
- Store within an ambient temperature range of 0 to 65° C (32 to 149° F).
- Store within a relative humidity range of 5% to 95%, non-condensing.
- Do not store equipment where it could be exposed to a corrosive atmosphere.
- Do not store equipment in a construction area.

Isolation Transformer

1391 – T 015 D T

First Position Bulletin Number	Second Position Type	Third Position kVA Rating		Fourth Position Primary Voltage & Frequency		Fifth Position Secondary Voltage		
	Let- ter	Description	Num- ber	kVA	Letter	Description	Letter	Description
	T	Trans- former Open Core and Coil	015 035 050 100 125 150	1.5 3.5 5.0 10.0 12.5 15.0	D	240/480V AC, Three- Phase, 60 Hz	T	230V AC, three- phase and four 36V AC, single- phase C.T.wind- ings
					E	240/380/415/480V AC, Three-Phase, 50/60 Hz		
					N	208/230/460/575V AC, Three-Phase, 60 Hz		

NEMA Type 1 Transformer Enclosure
Kit

1391 – TA2

First Position Bulletin Number	Second Position Accessory Module	
	Let- ter	Description
	TA	Fits all kVA ratings on 1388, 1389 and 1391 Isolation Transformers.
	2	

Bulletin 1391B-ES Controller

1391B – ES A A 45 – XXX

First Position Bulletin Number	Second Position Speed Capability	Third Position Type and Construction	Fourth Position Nominal Output Voltage	Fifth Position Current Rating	Sixth Position Options (if required)
Code Description	Letter Description	Letter Description	Letter Description	Number Description	Description
B Standard	Blank 1391B ES Extended Speed Range	A Open Frame, Internal Heat Sink	A 230V AC, Three- Phase	15 15A RMS Cont./ 30A Peak 22 22.5A RMS Cont./ 45A Peak 45 45A RMS Cont./ 90A Peak	Three character field assigned to special modifications. Contact your local Allen-Bradley Sales Representative for further information. Code Description A12 Must be or- dered when using rare- earth motors

Accessory Modules

1388 – X B

First Position Bulletin Number	Second Position Accessory Module	Third Position Accessory
Code	Description	Description
A	Anti-Backlash Module w/mounting assembly	
B	Accel/Decel Board w/mounting rack	
C	Velocity Reference Board w/mounting rack	

External Shunt Regulator Resistor

1326 – MOD – SR22A

First Position Bulletin Number	Second Position Type	Third Position Description
Code	Description	Code Description
MO D	Modifica- tion Kit	SR22 Shunt Regulator Resistor for 22.5A Controller SR45 Shunt Regulator Resistor for 45A Controller

1326AB Servomotor

1326 A B – A 3 E – 11 – A4

First Position Bulletin Number	Second Position		Third Position	Fourth Position	Fifth Position	Sixth Position	Seventh Position		Eighth Position Standard Options
	Type	Description	Design	Series	Motor Length	Max. Op. Speed	Mounting & Shaft Description		
	Let- ter	Description	Descrip- tion	Description	Description	Let- ter	RPM	Cod e	Description
	A	AC Servomo- tor PM Type	Factory use only	Sequentially lettered to designate frame diame- ters.	Sequential- ly num- bered to indicate stack length with- in a given frame size.				
				Code Description					
				A 4.25"					
				B (108 mm)					
				C 5.88"					
				(149 mm)					
				7.63"					
				(194 mm) Oil Seal Kit					
						Code Description			
						A4 72 lb.-in. (8.1 N-m) Holding Brake w/90V DC Coil.			
						A5			
						A7 120 lb.-in. (13.6 N-m) Holding Brake w/90V DC Coil.			
						360 lb.-in. (40.7 N-m) Holding Brake w/90V DC Coil.			

1326A – MO – SS V – A 1
B D

First Position Bulletin Number	Second Position		Third Position	Fourth Position	Fifth Position	Sixth Position	
Type	Description	Shaft Seal	Material	Motor Series	Motor Mounting ¹		
	Code	Description	Letter	Description	Letter for . . .	Num- ber	Description
	MO	Modifica- tion Kit	V	Viton	A -A Series	1	Std. Inch
	D				B -B Series	2	Metric
					C -C Series		

¹ "A" Series motors with brake must use 1326AB-MOD-SSV-A2.

Brake Power Supply Rectifier

1326 – MO – BP
D S

First Position Bulletin Number	Second Position	Third Position
Type	Description	Description
	Code	Description
	MO	Modifica- tion Kit
	D	
	BP	Single-phase, full-wave, screw mount rectifier. 115V AC input, for use with 90V DC brakes. ²
	S	

² Up to 4 brakes per rectifier can be used.

Motor Junction Box Kit³

1326A B	– MO D	– RJA B										
First Position Bulletin Number	Second Posi- tion Type <table style="width: 100%; border-collapse: collapse;"> <thead> <tr> <th style="border-bottom: 1px solid black;">Code</th> <th style="border-bottom: 1px solid black;">Description</th> </tr> </thead> <tbody> <tr> <td>MO D</td> <td>Modifica- tion Kit</td> </tr> </tbody> </table>	Code	Description	MO D	Modifica- tion Kit	Third Posi- tion Description <table style="width: 100%; border-collapse: collapse;"> <thead> <tr> <th style="border-bottom: 1px solid black;">Code</th> <th style="border-bottom: 1px solid black;">Description</th> </tr> </thead> <tbody> <tr> <td>RJA B</td> <td>For all AB-A and AB-B Series Motors</td> </tr> <tr> <td>RJB C</td> <td>For all AB-B4 and AB-Cx Series Motors</td> </tr> </tbody> </table>	Code	Description	RJA B	For all AB-A and AB-B Series Motors	RJB C	For all AB-B4 and AB-Cx Series Motors
Code	Description											
MO D	Modifica- tion Kit											
Code	Description											
RJA B	For all AB-A and AB-B Series Motors											
RJB C	For all AB-B4 and AB-Cx Series Motors											

³ The motor comes standard with IP65 plug style connectors mounted radially to the motor. This kit allows the connectors to be brought out axially to the motor without further wiring. Kit includes Motor Junction Box and Mounting Hardware.

Feedback Mounting Adapter Kit⁴

1326A B	– MO D	– M4 –	C 1										
First Position Bulletin Number	Second Posi- tion Type <table style="width: 100%; border-collapse: collapse;"> <thead> <tr> <th style="border-bottom: 1px solid black;">Code</th> <th style="border-bottom: 1px solid black;">Description</th> </tr> </thead> <tbody> <tr> <td>MO D</td> <td>Modifica- tion Kit</td> </tr> </tbody> </table>	Code	Description	MO D	Modifica- tion Kit	Third Posi- tion Mounting Adapter Kit for . . .	Fourth Position Coupling Size for . . . <table style="width: 100%; border-collapse: collapse;"> <thead> <tr> <th style="border-bottom: 1px solid black;">Code</th> <th style="border-bottom: 1px solid black;">Motor Series</th> </tr> </thead> <tbody> <tr> <td>C1</td> <td>A, B, C</td> </tr> <tr> <td>Blan k</td> <td>For M22, M23, M24, M25, M26</td> </tr> </tbody> </table>	Code	Motor Series	C1	A, B, C	Blan k	For M22, M23, M24, M25, M26
Code	Description												
MO D	Modifica- tion Kit												
Code	Motor Series												
C1	A, B, C												
Blan k	For M22, M23, M24, M25, M26												

Code	Description
M4	A-B 845H/T Encoder for AB-A series motor
M5	A-B 845H/T Encoder for AB-B series motor
M6	A-B 845H/T Encoder for AB-C series motor
M22	Type VC/VD 4.25" (108 mm) Resolver for AB-B series motor
M23	Type VC/VD 4.25" (108 mm) Resolver for AB-C series motor
M25	0.375" (9.5 mm) diameter heavy duty shaft extension adapter
M26	0.625" (15.9 mm) diameter heavy duty shaft extension for type VC/VD 4.25" (108 mm) resolver
	Foot mounting kit for M25

⁴ All kits contain a feedback device mounting adapter and mounting hardware. M4, M5 and M6 include a motor to encoder coupling. M22 and M23 do not include a coupling since it is included with the resolver feedback device.

Feedback Coupling

1326 – MO – C1
D

First Position Bulletin Number	Second Position Type		Third Position Coupling Size	
	Code	Description	Code	Size - Motor Shaft to Encoder Shaft
	MO	Modifica- tion Kit	C1	3/8" to 3/8" (9.5 mm to 9.5 mm)
	D		C2	3/8" to 1/4" (9.5 mm to 6.3 mm)

Resolver Feedback Package

1326A – MO – VC 1:1
B D

First Position Bulletin Number	Second Position Type		Third Position Resolver Feedback Package	Fourth Position Gear Ratio Input:Resolver
	Code	Description		
	MO	Modifica- tion Kit ⁵		

Code	Description
VC	4.25" (108 mm) feedback package with cast housing and single or vernier (dual) format with receiver (Harowe 11BRW-300-F-58A or equivalent) type resolver(s) for use with 8200, IMC 120, IMC 123, Creonics SAM and MAX.
VD	4.25" (108 mm) feedback package with cast housing and single or vernier (dual) format with transmitter (Harowe 11BRCX-300-C10/6 or equivalent) type resolver(s) for use with A-B series 8600 and Creonics.

Code	Description
1:1	Single device format – 1 turn of the motor shaft to 1 turn of the resolver.
1:2	Single device format – 1 turn of the motor shaft to 2 turns of the resolver.
1:2.5	Single device format – 1 turn of the motor shaft to 2.5 turns of the resolver.
1:5	Single device format – 1 turn of the motor shaft to 5 turns of the resolver.
255	Absolute master/vernier format – 1:1 input/master, 255:256 master/vernier for IMC 120, 123 only.
256	Absolute master/vernier format – 1:1 input/master, 256:255 master/vernier for 8600 series controls and Creonics only.

⁵ Kit includes Resolver Feedback Package, mounting hardware and 3/8" to 3/8" (9.5 mm to 9.5 mm) resolver to motor mounting coupling.

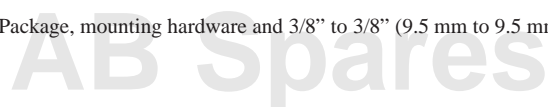

Power and Feedback Cables

1326 – C P T A B 15

First Position Bulletin Number	Second Position Type	Third Position Function	Fourth Position Power Track Cable	Fifth Position Motor Size Used On	Sixth Position Cable Length
	Letter Description	Letter Description	Letter Description	Code Type	Code Description
	C Connector & Cable Assembly	P Power Connection	T All Series	AB Series A & B (except 1326AB-B4)	K Connector Kit (No Cable)
	CC Connector on both ends (for use with 1391C-HB)	F Commutation & Feedback Connection	Blank Standard Cable	C Series C & 1326AB-B4	15 15' (4.6m)
		E 845H Encoder		U All Series	30 30' (9.1m)
		V All 4.25" (108 mm) Resolver Packages			50 50' (15.2m)
					100 100' (30.4m)

Blower Mod Kit

1326A – MO – G3
B D

First Position Bulletin Number	Second Position Type	Third Position Description
	Code Description	Code Motor Series
	MO Modification Kit	G3 Rear mounted blower for C series motors
		G4 "Saddle" type blower for C series motors with encoders

End of Chapter

Description of Operation

Chapter Objectives

Chapter 4 is intended to familiarize the reader with the circuitry of the 1391B-ES in terms of function and operation.

General

The 1391B-ES PWM Servo Controller is made up of the following: 300V DC power supply, power transistor output modules, shunt regulator circuit, logic power supply, Logic Control Boards, isolated current sensing, circuit breaker and line contactor.

The intended use of the 1391 ES is to control the speed and torque of an AC servomotor in a closed loop position system. A complete servo system can be configured with a 1391B-ES Servo Controller, 1326 AC Servomotor and 1391 Isolation Transformer. Refer to the 1391B-ES Block Diagram presented in Figure 4.3.

300V DC Power Bus Supply

The controller contains an integral, unregulated, 300V DC nominal, full load power supply. It consists of the power transformer input (230V AC, three-phase, 50 or 60 Hz), a three-phase input bridge rectifier and one power supply filter capacitor (C1).

PWM Operation

The 1391B-ES incorporates a fixed timing wave (V_T) of 2500 Hz. The controller also generates a three-phase sine wave whose frequency corresponds to the velocity command. An output voltage signal (V_O) is generated by the intersection of these two curves as shown in Figure 4.1.

Figure 4.1
PWM Waveform

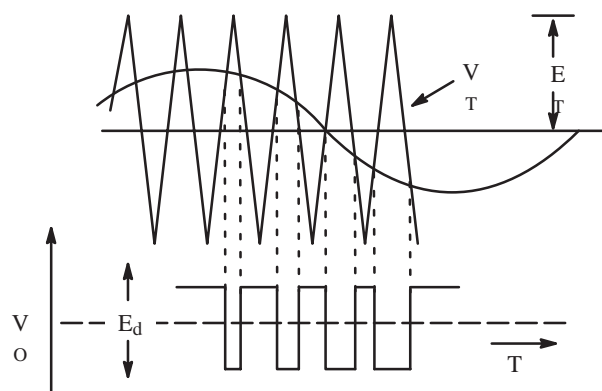

The three-phase relationship between the reference signal and the timing wave provide a PWM wave to the power transistor base drive. This base drive switches the power transistors across the 300V DC bus, providing current to the motor windings, thus causing the motor to turn. A resolver attached to the motor provides a signal corresponding to the actual rotor position of the motor. This signal is decoded to a signal representing rotor position and is fed to the commutation logic along with the torque command. In this way, the controller combines the desired position signal and current reference with the decoded resolver signal to produce a reference signal commanding the controller to speed up or slow down. See Figure 4.2.

Figure 4.2
Operation

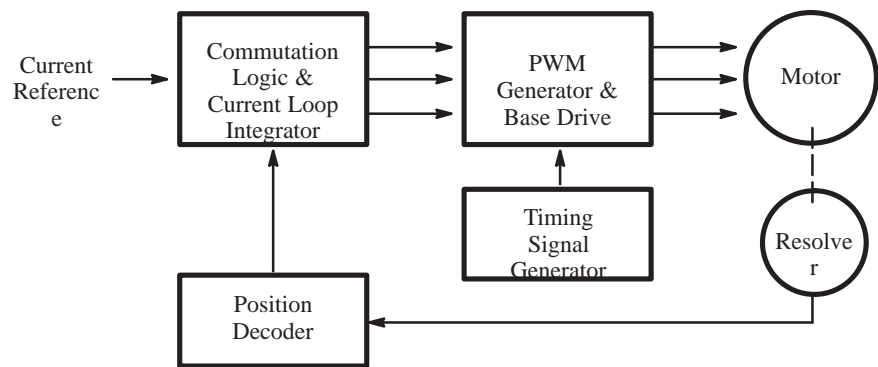

Shunt Regulator Operation

The 1391B-ES shunt regulator provides power dissipation for regenerative conditions when the energy returned to the controller by the motor exceeds that which can be stored in the bus capacitors. The shunt regulator monitors the bus voltage and at a predetermined “ON” point activates the shunt regulator transistor, allowing current to flow through the shunt resistor and dissipating power in the form of heat. A fuse is placed in series with the resistor to protect it against short circuit conditions. When the shunt transistor is activated and power is being dissipated at the resistor, the bus voltage will quickly decrease, turning the transistor off when the voltage reaches the “OFF” point. This cycle repeats, provided the bus voltage continues to increase to the “ON” point. If too much regenerative energy is present, the bus voltage will continue to increase even with the shunt regulator on. At a predetermined bus voltage level, the 1391B-ES will determine that an overvoltage condition exists, and trip out on an Overvoltage Fault.

The shunt regulator behavior is further modified by an adjustable duty cycle timer. The timer is used to model the shunt resistor temperature. SW1, a selector switch located on the top of the controller (see Figure 1.1) determines the temperature level and therefore the average power level at which the controller will trip out. When this level is reached, the controller will be forced to trip out on an Overvoltage Fault. This action would be equivalent to turning the shunt regulator off. Refer to Chapter 9 for further shunt regulator information.

Logic Power Supply

The 1391B-ES control logic voltage is $\pm 12\text{V DC}$ and $+5\text{V DC}$. The voltages are generated on the Power Driver Board, which receives its 36V AC center-tapped input from a tertiary winding on the isolation transformer.

Logic Control Boards

The Logic Control Boards are the printed circuit boards that are readily accessible behind the front cover of the controller. They contain all circuits necessary to control the 1391B-ES. These circuits include: the velocity and current loop, fault detection and annunciation circuits, power-up/power-down logic, PWM generation and forward/reverse controlling circuits.

Figure 4.3
1391B-ES Block Diagram

Fault Monitoring and Detection

A number of Fault Monitor and Detection functions exist on the 1391B-ES that guard the controller and help to minimize motor and system faults. The occurrence of a fault will cause the controller to trip out. In this condition, the Drive OK (DROK) contact will open and remain open until the fault is cleared. If the DROK contact is wired into the user's stop circuit, the line/DB contactor (M) will also de-energize. This will place the shunt resistor across the bus causing the motor to dynamic brake to a stop.

These fault conditions are annunciated through the front panel LED indicators. The conditions displayed include:

Overtemperature

The controller contains a thermal switch on the heat sink which indirectly senses transistor module temperature. If the temperature rating of the switch is exceeded, the LED illuminates, the DROK contact opens and the controller is disabled.

Power Fault

A fault related to the power bridge section of the controller will cause the controller to be disabled, illuminate the LED and open the DROK contact.

Control (Power) Fault

If the control voltage varies more than $\pm 10\%$ of the nominal 12V DC or the resolver wiring is grounded or missing, this fault will occur. When a fault is detected, the LED illuminates, the DROK contact opens and the controller is disabled.

Overvoltage

The DC power bus voltage is continuously monitored. If it exceeds a preset level of 405V DC, the LED illuminates, the DROK contact opens and the controller is disabled.

Undervoltage

If the DC power bus voltage drops below 50% of its nominal operating value, the LED illuminates and a signal will be present at TB2-13. A switch setting on S2 selects the reaction of the DROK contacts to an undervoltage detection. Two options are possible: 1) DROK opens, but closes when the bus voltage is restored; 2) DROK is not affected by an undervoltage.

Important: Regardless of interaction with the DROK contacts, the transistor bridge is disabled upon an undervoltage condition. This is done to protect the output transistors against voltage transients.

Current Foldback

The controller contains a fixed time versus current overload circuit which monitors the current through each leg of the output bridge. If a fixed-time versus current-product is exceeded, the LED is illuminated and a signal will be present at TB2-14. This condition will reduce the current limit or torque available to the motor.

Run/ Enable

The application of an enable signal by the machine position controller will cause the RUN ENABLE LED to illuminate.

Drive Ready

The status of the power supplies and fault conditions are monitored continuously. If a fault is present, the DRIVE READY LED will not be illuminated, a fault signal will be present at TB4 and the DROK contact will be open.

Isolated Current Sensing

The Logic Control Boards receive current feedback from the Isolated Current Sense Board. This circuitry provides the data used for current limiting and to modify bandwidth.

Integral Circuit Breaker

The control logic and power circuitry are protected against overcurrents by an integral circuit breaker. The DC bus supply and input rectifier utilizes a three pole magnetic circuit breaker.

Line/DB Contactor

The three-phase incoming AC line is opened by the contactor whenever the Enable signal is removed or a fault occurs. This operation in conjunction with the shunt regulator reduces the bus voltage when the contactor is disabled. The Logic Control Board remains energized except when voltage is removed from the incoming isolation transformer.

Important: The 1391B-ES contains a definite purpose contactor that is not to be energized/de-energized more than twice an hour on a continuous basis. The life of the contactor may be reduced considerably if the cycle is exceeded. Contact your local Allen-Bradley Sales Representative for additional information.

Power Driver Board

The Power Driver Board contains the circuitry needed to switch the power transistor modules.

A Quad B Board

The A Quad B Board changes the resolver signal from a 1326AB or AD motor into an encoder signal for use by a position controller.

Starting and Stopping



ATTENTION: The Enable control circuitry in the 1391B-ES includes solid-state components. If hazards due to accidental contact with moving machinery or unintentional flow of liquid, gas or solids exist, an additional hardwired stop circuit may be required. Refer to the codes and standards applicable to your particular system for specific requirements and additional information. A device that removes AC input power when a stop is initiated is an integral part of this controller. Refer to the following individual stop mode explanations.



ATTENTION: The user has the ultimate responsibility to determine which stopping method is best suited to the application and will meet applicable standards for operator safety.

Starting and Stopping must be accomplished by hardwired user supplied elements as shown in Appendix B. Stopping modes for the 1391B-ES are outlined below. Refer to the paragraphs that follow for detailed information. The effects described below assume that the 36V AC control voltage has not been de-energized.

<u>Cause</u>	<u>Effect on Motor</u>
De-energize Line/DB Contactor (M) Coil	Dynamic Brake
Speed Command brought to Zero	Regenerative Brake
Open Enable Input	Regenerative Brake
DROK Opens (Fault)	Coast to Stop

Dynamic Braking

When the line/DB contactor (M) is de-energized by the control circuitry, an inherent dynamic braking effect will occur during the DC bus decay, provided the 36V AC logic voltage is not de-energized. The dynamic braking effect depends on the value of the shunt regulator resistor and total load inertia.

Important: Frequent cycling of the line/DB contactor to start/stop the motor will reduce the life of the contactor. Refer to the paragraph that follows.

Regenerative Braking

Normal run commands to the controller are performed through the Enable input and any additional customer supplied control circuitry. Refer to Appendix B. With input power applied, a mechanical contact closure between TB2-9 & 10 or solid-state contact closure (open collector, +15 to +30V DC) between TB2-10 & 12 will cause the controller to run, provided the line/DB contactor (M) has been energized by the control circuitry. When the Enable input is de-energized, the maximum available reverse torque is applied to the motor in a regenerative stopping mode, which will occur for approximately 450ms.

Coast

An internal controller fault opens the DROK contact. Coasting will only occur if the DROK contact is not wired to the line/DB contactor coil (M) or the Enable input circuits.

Power-Up/Down Sequence

Figure 4.4 describes the various steps involved in the power-up/down sequence of the 1391B-ES controller.

Figure 4.4
Controller Power-Up / Down Sequence

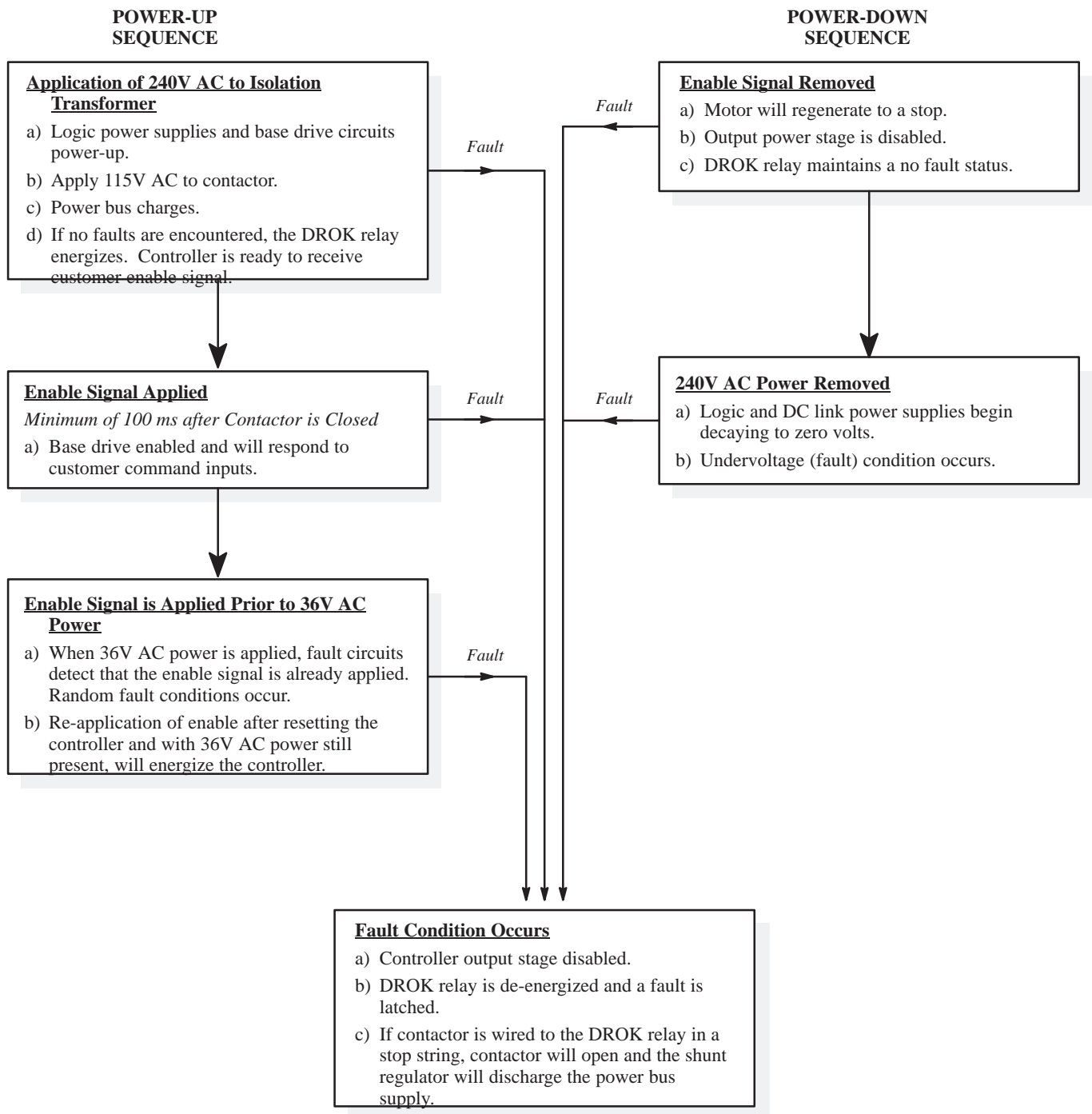

End of Chapter

AB Spares

Inputs, Outputs and Adjustments

Chapter Objectives

Chapter 5 contains descriptions of the various inputs and outputs available on the 1391B-ES Servo Controller. Additionally, a comprehensive listing and description of the potentiometer and switch adjustments is provided. In some cases adjustment methods are provided for use during start-up. This information is provided to help you understand some of the important aspects about the controller prior to the actual installation and start-up. For information on shunt regulator adjustments, refer to Chapter 9.

Inputs/Outputs

The following paragraphs provide detailed descriptions of the various inputs and outputs available for the 1391B-ES. See Figure 5.2 for terminal block locations.

Terminal Block - TB1

Resolver Signals (TB1, Terminals 1-10)

These terminals are used for connection to the resolver. Refer to Appendix B for connection details.

Terminal Block - TB2

Velocity Command Input (TB2, Terminals 1, 2)

The controller will accept up to a $\pm 10V$ DC velocity command signal to achieve maximum motor speed. The plus (+) and minus (-) reference are at terminals 2 and 1, respectively. Shield must be terminated at source end only. The differential impedance of the velocity command input is 40k ohms (20k ohms for single ended inputs).

Signal Common (TB2, Terminals 3, 6, 12, 17)

Signal input reference point.

Buffered Output (TB2, Terminal 4)

This output is the differentially isolated velocity or torque command applied at terminals 1 and 2 of TB2. It can be wired to the torque command input (TB2-15 and 16) for torque block operation.

Adjustable Current Limit (TB2, Terminal 5)

The current limit of the controller is set to 300% or twice the continuous rating of the controller, whichever is lower. Connecting this terminal to Signal Common will enable potentiometer R148. The range of this pot is 20 to 300% or twice the continuous rating of the controller, whichever is lower. This is used for feed to hard stop applications. When the workpiece activates this condition through a limit switch or other user supplied device, the current will be limited to the value set by R148, protecting the motor against possible overheating.

Tachometer Output (TB2, Terminal 7)

A voltage corresponding to the motor velocity and direction of rotation will be present between this terminal and Signal Common. With switch S2-1 (see the section entitled *Switch Settings*) set to “ON,” a voltage of $\pm 1.2V$ DC/1000 rpm will be present. With the switch in the “OFF” position, a voltage of $\pm 2.0V$ DC/1000 rpm will be present.

I Command Output (TB2, Terminal 8)

The voltage present between this terminal and Signal Common corresponds to the motor current. A voltage of $\pm 3.0V$ DC equals the rated motor current as set by switch S1.

Enable Input (TB2, Terminals 9, 10)

Normal Run commands to the controller are performed through the Enable input and any additional user supplied run control circuitry. With input power applied and the line contactor energized, a solid-state contact closure (rated +15 to +30V DC, 30 mA) between TB2-10 & 12 or a mechanical contact closure between TB2-9 & 10 will cause the controller to run. When this input is de-energized, the control will cause a regenerative braking action in the motor.

Reset (TB2, Terminal 11)

Removing the Enable signal and momentarily connecting this terminal to Signal Common will reset the controller after a controller fault occurs.

Important: A Reset must not be initiated until the cause is determined and corrected.

Low Bus (TB2, Terminal 13)

This terminal provides an open collector output rated at 12V DC, 5mA to indicate a low bus voltage condition. Reference to Signal Common.

Current Foldback (TB2, Terminal 14)

This terminal provides an open collector output rated at 12V DC, 5mA to indicate that current foldback is in operation. Reference to Signal Common.

Torque Command Input (TB2, Terminals 15, 16)

Terminals 15 and 16 provide a small amount of input filtering for operating the controller in a torque block or velocity feedforward mode. A $\pm 3V$ DC command equals 100% of the S1 current setting (i.e. motor rated current).

The buffered output of the command at terminal 4 of TB2 can be connected to terminal 16 if more filtering is desired.

Spares (TB2, Terminals 18-20)

Reserved for future use and are not to be used.

Terminal Block - TB3 (A Quad B Board)

Figure 5.1 provides interconnect information between the position controller and TB3 on the A Quad B Board.



ATTENTION: To guard against possible damage to the A Quad B Board, assure that wiring between TB3 and the position controller is correct. Refer to Figure 5.1.

Figure 5.1
A Quad B Board Wiring

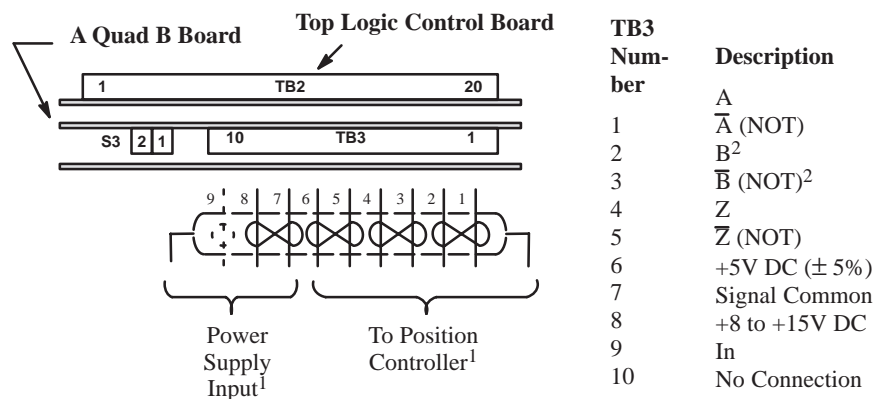

Important: Note terminal orientation prior to wiring.

¹ Recommended Wire – Belden #9728 or equivalent. Maximum distance between the A Quad B Board and the position controller is 40 feet (12.2 meters) using a 5 volt signal. For distances up to 300 feet (91 meters), 18 AWG (0.8 mm²) wire and an 8 to 15V DC power supply must be used.

² For proper operation when interconnecting to IMC products, the B and \bar{B} (NOT) signals must be reversed.

When interfacing to IMC 121 or 123 controllers, use the 1391-CAQB cable.

The A Quad B option operates in the same manner as the Allen-Bradley 845H Line Driver Encoder (26LS31 line driver output). The option requires either a regulated +5V DC at terminal 7 or an unregulated +8 to +15V DC input at terminal 9 (board draws 125mA maximum). The pulse train output is selectable to 256, 512, 1024 or 2048 lines per revolution via the Encoder Output switch, S3 (see page 5-36).

Terminal Block - TB4

Drive OK (DROK) Contacts (TB4, Terminals 17, 18)

Application of power to the transformer energizes the logic supply of the controller. When 90% of rated DC Bus voltage is achieved and no controller faults are detected, this relay contact is closed. The contact remains closed until a controller fault occurs or power is removed from the transformer. Contact rating: 115V AC, 1A or 24V DC, 0.3A. Refer to *Switch Settings – Drive OK/Drive Ready* on page 5-35 for further information.

36V AC Logic Supply Voltage (TB4, Terminals 19, 20, 21)

The isolation transformer contains four separate windings. Each winding supplies 36V AC with a center tap. The 36V AC leads are brought out to terminals 19 and 21 of TB4. The center tap must be connected to terminal 20 of TB4. See Chapter 9 for transformer details.

Terminal Block - TB5

Motor Power Terminals (TB5, Terminals 1, 2, 3)

Motor power is provided at these terminals. Refer to Chapter 6 and Appendix B for connection details.

Input Power Terminals (TB5, Terminals 4, 5, 6)

The controller requires a 230V AC, three-phase, 50 or 60 Hz input supplied by the transformer secondary. Refer to Chapters 6, 9 and Appendix B for wiring and transformer information.

External Shunt Regulator Resistor (TB5, Terminals 8, 9, 10)

The 22.5A controllers have provisions to accept an external shunt resistor to supplement the integral unit. This is available for applications that require the dissipation of more regenerative energy to the DC Bus. To use an external shunt resistor, first remove the jumper at terminals 8 and 10 of TB5. Consult the Allen-Bradley sales office for application assistance.

The shunt regulator resistor supplied with the 1391B-ESAA45 must be externally mounted and connected to terminals 8 and 9 of TB5 prior to operation. Refer to Chapter 9 and Appendix B for details.

Figure 5.2
Terminal Block, Potentiometer and Switch Locations

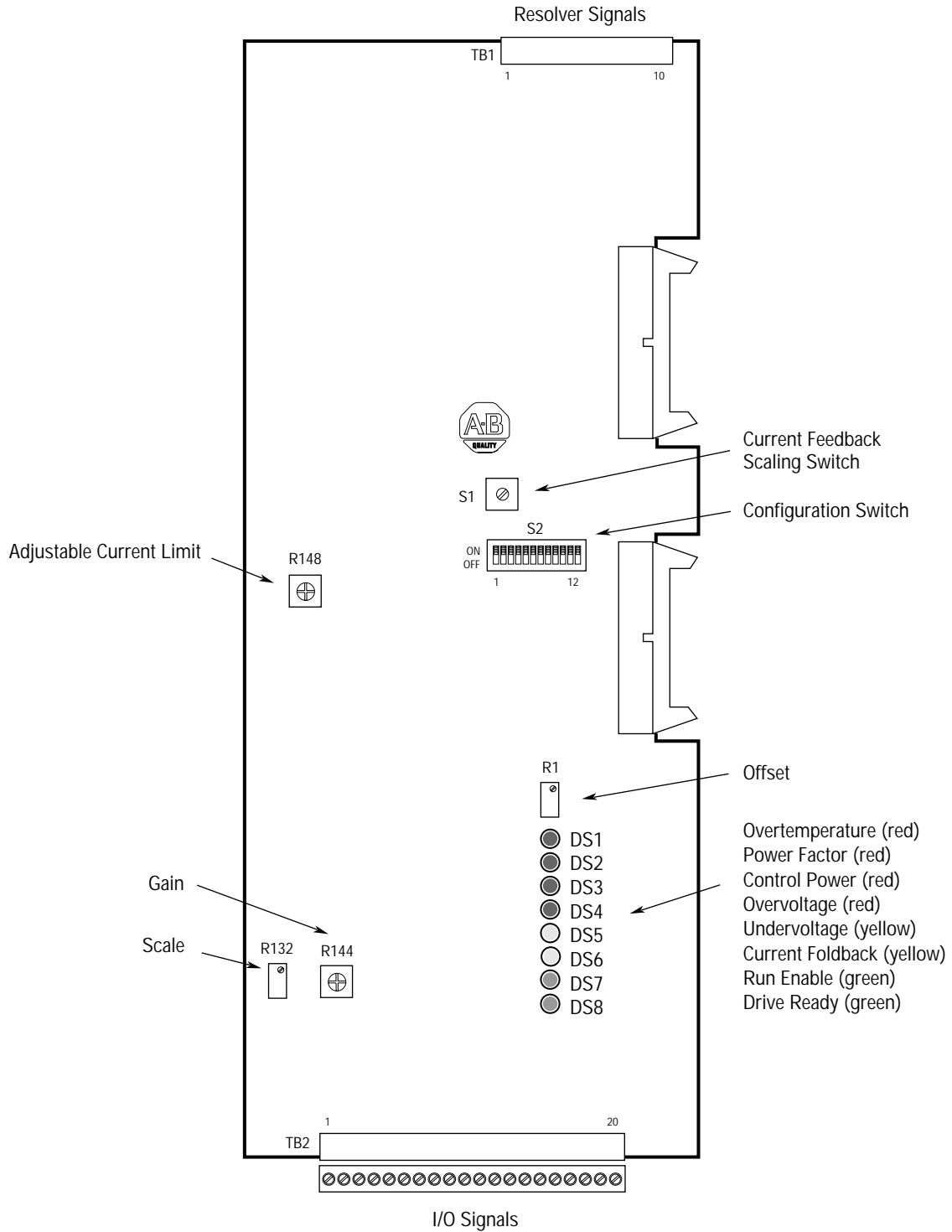

Potentiometer Adjustments

Preliminary adjustment of the Logic Control Board potentiometers is required as explained below. Descriptions of the potentiometers follow.

Initially the potentiometers shall be set as shown in Table 5.A. See Figure 5.2 for potentiometer locations.

Table 5.A
Initial Potentiometer Settings

Potentiometer	Setting
Current Limit (R148)	10
Velocity Gain (R144)	4
Offset (R1) and Scale (R132)	Leave at the present setting until adjustment becomes necessary in the Start-Up Procedure.

Current Limit (R148)

This single turn potentiometer adjusts the maximum current available to the servomotor when TB2-5 is grounded. The maximum setting is 300% of the motor rating or twice the continuous rating of the controller, whichever is lower. The pot can be calibrated (fine tuned) using TP21 and the proportion: 3V DC=100% continuous motor current.

Velocity Gain (R144)

This potentiometer is used to fine tune the response characteristics of the system. Clockwise rotation increases the dynamic gain of the servo amplifier, while counterclockwise rotation decreases gain. When used in conjunction with the integral gain switch, the system response can be adjusted over a wide range.

Offset (R1)

Adjustment for the system offset voltages is provided by this multi-turn pot.

Velocity Command Scale (R132)

This adjustment is a multi-turn pot that scales the command signal with the velocity feedback signal.

Switch Settings

This section provides information on setting the Duty Cycle Selector switch (SW1), Current Scaling switch (S1), configuration switches (S2) and the A Quad B Encoder Output switch (S3). Refer to Figure 5.2 for switch locations. Note that the settings for 1326AP motors are the same as 1326AB motors.

Duty Cycle Selector Switch - SW1

The Duty Cycle Selector Switch (SW1) which is located on top of the controller, modifies the behavior of the shunt regulator. The switch determines the temperature level and therefore the average power level at which the controller will fault. Refer to Chapter 9 for detailed switch setting information.

Current Feedback Scaling Switch - S1

The 1391B-ES employs a current feedback scaling circuit which allows a controller to be used with 1326 AC Servomotors having lower current ratings.

Tables 5.B and C provide the information necessary to correctly set the current feedback scaling using switch S1. Table 5.B provides general information on switch settings for typical motor / controller combinations. Table 5.C provides examples of switch settings for specific 1326 AC Servomotors. Refer to the motor nameplate for actual rated current (I_C is continuous current rating in amperes).

Important: The motor and controller rated current (as listed on their respective nameplates) should be noted and the correct adjustment of switch S1 made prior to applying power to the system.

Set S1 to a position equal or nearest to the rated motor current. One setting higher must be used if the motor current is between current ratings. Once the current feedback scaling is set, the current limit and peak current capabilities will be a function of the motor current rating and not the controller current rating.

Table 5.B
Typical Current Feedback Scaling

Motor Rated Current			S1 Switch Setting
1391B-ESAA1	1391B-ESAA2	1391B-ESAA4	
5	2	5	F
15.0	22.5	45.0	E
14.1	21.1	42.2	D
13.1	19.7	39.4	C
12.2	18.3	36.6	B
11.3	16.9	33.8	A
10.3	15.5	30.9	9
9.4	14.0	28.1	8
8.4	12.6	25.3	7
7.5	11.3	22.5	6
6.6	9.8	19.7	5
5.6	8.5	16.9	4
4.7	7.0	14.1	3
3.8	5.7	11.3	2
2.8	4.2	8.4	1
1.9	2.8	5.6	0
0.9	1.4	2.8	

Table 5.C
Typical Scaling for 1326 AC Servomotors

Motor Catalog Number ²	I _C (A)	S1 Switch Setting ¹		
		1391B-ESAA1	1391B-ESAA2	1391B-ESAA4
1326AB-A1E	2.6	5	2	5
1326AB-A2E	5.2	2	1	
1326AB-A3E	7.8	5	3	
1326AB-B1C	5.7	8	5	
1326AB-B1E	8.2	6	4	
1326AB-B2C	11.4	8	5	
1326AB-B2E	16.4	C	8	
1326AB-B3C	17.0		B	5
1326AB-B3E	24.6		C	6
1326AB-B4E	35.7			8
1326AB-C1C	11.7			C
1326AB-C1E	16.6	C	8	
1326AB-C2C	23.3		B	5
1326AB-C2E	33.2			8
1326AB-C3C	34.4			B
1326AB-C3E	49.1			C
1326AB-C4B	38.2			F
1326AB-C4C	46.6			D
1326AD-K2G	4.8			F
1326AD-K3G	4.9	5	3	
1326AD-K4F	4.9	5	3	
1326AD-K5E	4.8	5	3	
		5	3	

¹ For reference only. Refer to motor nameplate for rated current value.

² Settings for 1326AP and 1326AB AC motors are identical. If using blower, increase the motor rated current by 35% and set S1 accordingly.

Configuration Switch - S2

Prior to start-up, the switch positions of S2 must be checked against the listing in Table 5.D to ensure proper setting. Refer to the paragraphs following the table for switch descriptions.



ATTENTION: Only personnel familiar with the 1391B-ES controller and its associated machinery should plan or implement the adjustment, calibration, start-up and subsequent maintenance of the controller. Failure to comply may result in personal injury and/or equipment damage.



ATTENTION: An incorrectly applied or calibrated controller can result in component damage or a reduction in product life. Wiring or application errors, such as, undersizing the motor, incorrect or inadequate AC supply, or excessive ambient temperatures may result in malfunction of the controller.

Table 5.D
S2 Switch Descriptions (* Denotes factory setting for 1326AB motors)

Switch	Function	Description/Setting
S2-1	Tachometer Scaling	ON 1.2V / krpm 1326AB-Axx and 1326AD motors OFF 2.0 / krpm 1326AB-Bxx & 1326AB-Cxx motors up to 4000 rpm*
S2-2	I _D Cut In	See Table 5.E
S2-3	I _D Magnitude	ON 1326AB motors* OFF 1326AD motors
S2-4	Drive OK / Drive Ready	ON DROK closes if no faults are detected and the bus voltage is up* OFF DROK closes if no faults are detected, with or without bus voltage
S2-5	Torque Block / Velocity Loop Operation	ON Torque block operation OFF Velocity loop operation*
S2-6	Velocity Loop Compensation	ON Reduces integral gain (bandwidth) for high inertia systems OFF Normal gain*
S2-7, 8	Error Amp Gain	Reduces velocity loop gain when running 1326AD motors <u>S2-7</u> <u>S2-8</u> <u>Gain Reduction</u> OFF OFF None* OFF ON 33% ON OFF 33% ON ON 50%
S2-9, 10	Tachometer Filter	Additional filtering in tach feedback circuit for mechanical resonances, etc. <u>S2-9</u> <u>S2-10</u> <u>Filter Bandwidth</u> OFF OFF 430 Hz* OFF ON 284 Hz ON OFF 204 Hz ON ON 165 Hz
S2-11, 12	Staircase Filtering	Introduces additional filtering to the velocity command from positioning controller to minimize staircasing effects from the DAC output <u>S2-11</u> <u>S2-12</u> <u>Filter Bandwidth</u> OFF OFF – * OFF ON 159 Hz ON OFF 159 Hz ON ON 79 Hz

Tachometer Scaling (S2-1)

Switch S2-1 is used to configure the 1391B-ES tachometer synthesis circuitry to a range appropriate for the applied motors. Select the “ON” position for 1326AD and 1326AB-Axx motors and speeds to 6000 rpm. “OFF” is used for 1326AB-Bxx and Cxx motors to 4000 rpm.

ID Cut In (S2-2)

This switch sets the ID cut in speed. ID is a phase specific current added to the torque producing current at higher speeds to extend the performance range of the controller. The ID point differs with the motor used. Refer to Table 5.E for switch settings. For motors not listed, consult your Allen-Bradley Sales Representative.

Table 5.E
S2-2 Switch Positions

Motor Catalog Number ¹	S2-2 Switch Setting	Motor Catalog Number ¹	S2-2 Switch Setting
1326AB-A1E	ON	1326AB-C2C	OFF
1326AB-A2E	ON	1326AB-C2E	ON
1326AB-A3E	ON	1326AB-C3C	OFF
1326AB-B1C	OFF	1326AB-C3E	ON
1326AB-B1E	ON	1326AB-C4B	OFF
1326AB-B2C	OFF	1326AB-C4C	OFF
1326AB-B2E	ON	1326AD-K2G	OFF
1326AB-B3C	OFF	1326AD-K3G	OFF
1326AB-B3E	ON	1326AD-K4F	OFF
1326AB-B4E	ON	1326AD-K5E	OFF
1326AB-C1C	OFF		
1326AB-C1E	ON		

¹ Settings for 1326AP and 1326AB AC motors are identical. If using blower, increase the motor rated current by 35% and set S1 accordingly.

ID Magnitude (S2-3)

This switch is used to identify the type of motor being used. Set the switch to “ON” to signify a 1326AB motor and “OFF” for a 1326AD motor.

Drive OK/Drive Ready (S2-4)

This switch causes the DROK contacts to close under different circumstances.

If the switch is set to “ON,” the contact will close if no faults are detected and the bus voltage is nominal. An undervoltage condition will cause the DROK contacts to open.

If the switch is placed to the “OFF” position, the contacts will close once the undervoltage condition clears. Bus undervoltage will not effect the DROK contacts.

Torque Block/Velocity Loop Operation (S2-5)

Switch S2-5 is used to disable the velocity error amplifier to configure the controller for torque block operation. In torque block mode the controller acts as a current amplifier producing current (torque) proportional to the command present at terminals 15 and 16 of TB2. Note that the Command Scale and Velocity Loop Gain potentiometers (R132 & R144) have no effect in the torque block mode. Scaling for torque block is $\pm 3V$ Command = 100% of the S1 Current Setting (i.e. motor rated current). Place switch S2-5 to the “ON” position for torque block operation and “OFF” for velocity loop operation.

Velocity Loop Compensation (S2-6)

This switch is used to compensate the velocity loop for applications with higher load inertia. Position the switch to “ON” for high inertia compensation. High inertia compensation will generally improve performance on systems with load inertias greater than three times motor rotor inertia, although the user may wish to evaluate the impact of this compensation at slightly lower inertias.

Error Amp Gain (S2-7, 8)

1326AD motors require less gain on the velocity loop. Switches S2-7 and 8 reduce the gain by a fixed percentage. If both switches are “OFF,” there is no gain reduction. If either switch is ON, the gain will be reduced by 33%. If further gain reduction is required, both switches should be placed to “ON,” which provides a 50% reduction.

Tachometer Filter (S2-9, 10)

If the motor/tach is operating in a mechanically noisy system, additional tach filtering may be necessary. These switches offer four levels of filtering. Filter bandwidth can be decreased from 430 Hz. to 165 Hz. using the switch settings described in Table 5.D.

Staircase Filtering (S2-11, 12)

These switches provide additional filtering to minimize “staircasing” of the DAC output from the position loop controller. Three levels of velocity command filtering are available as shown in Table 5.D.

A Quad B Encoder Output Switch - S3

S3 selects the line count that will be output from the A Quad B Board.



ATTENTION: Incorrect setting of S3 can cause erratic and/or improper machine motion which may result in personal injury or equipment damage. Assure that switch S3 has been properly set as shown in Figure 5.3.

Figure 5.3
A Quad B Board Switch (S3) Settings

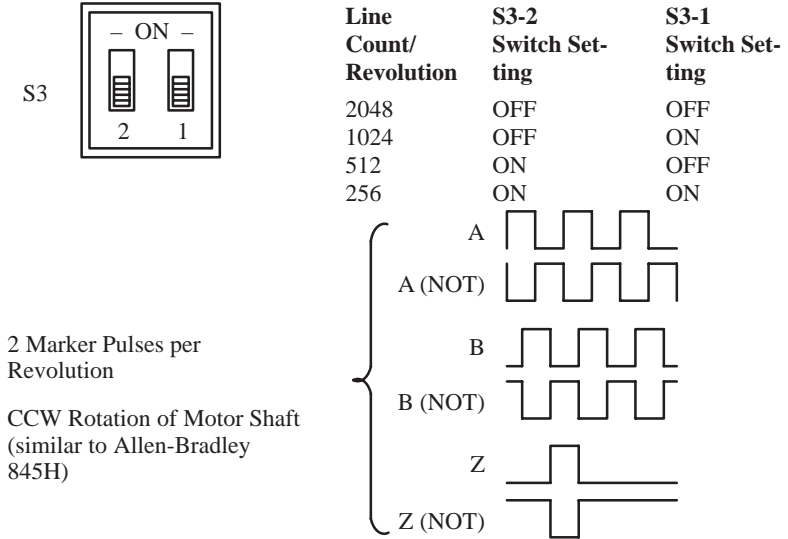

When using the A Quad B option with Allen-Bradley IMC motion controllers, the AMP parameters will be set according to the line count selected. In general, one parameter must be justified when using this device. The normal line counts per cycle of the encoder must be divided by two since the controller will see two markers per cycle.

Example (using an IMC 120 Controller)

With switch S3 set to 1024 lines per revolution (S3-2 OFF, S3-1 ON), the lines per cycle of the position feedback device (located in the Feedback Parameters File) must be 2048.

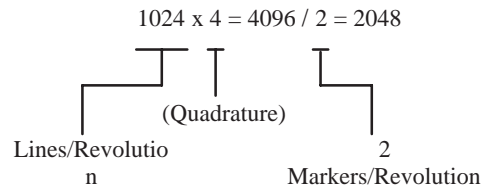

Installation

Chapter Objectives

Chapter 6 provides the information needed to mount and wire the 1391B-ES Servo Controller for operation. Since most start-up difficulties are the result of incorrect wiring, every precaution must be taken to assure that the wiring is done as instructed. **All items must be read and thoroughly understood before the actual installation begins.**



ATTENTION: The following information is merely a guide for proper installation. The National Electrical Code and any other governing regional or local code will overrule this information. The Allen-Bradley Company cannot assume responsibility for the compliance or the noncompliance to any code, national, local or otherwise for the proper installation of this controller or associated equipment. A hazard of personal injury and/or equipment damage exists if codes are ignored during installation.

Mounting

Mounting dimensions for the 1391B-ES Servo Controller can be found in Appendix A. Chapter 2 provides information on power dissipation and environmental specifications. The controller must be located on a flat, rigid, vertical surface and must not be subjected to shock, vibration, moisture, oil mist, dust, corrosive vapors, etc. or temperatures that exceed 60° C (140° F) ambient.

Controllers can be mounted adjacent to each other with a minimum clearance of 0.312" (7.9mm) between units and/or surrounding cabinetry and non-current carrying surfaces. However, it is recommended that a space of approximately 1.0" (25.4mm) be left between adjacent units to allow easy access and removal of the front cover. To allow for proper airflow, a minimum clearance of 3.0" (76.2mm) is required along the top and bottom of the unit and any adjacent components.

The transformer that supplies 230V AC, three-phase and 36V AC to each servo controller must have 3" (76.2mm) of clearance around it and any adjacent components. This will allow for proper airflow and wiring access. The transformer can be mounted in either a horizontal or vertical position.



ATTENTION: The installation of the controller must be planned such that all cutting, drilling, tapping and welding can be accomplished with the controller removed from the enclosure. The controller is of the open type construction and any metal debris must be kept from falling into it. Metal debris or other foreign matter may become lodged in the circuitry resulting in component damage.

Wiring Recommendations

General Information

The information supplied in this manual on wire sizes, practices, layouts, system configurations and grounding/shielding techniques for the 1391B-ES Servo Controller are presented as guidelines. Due to the diversity of applications and systems, no single method of wiring is completely applicable.

Important: This information represents common PWM servo system wiring configurations, size and practices that have proven satisfactory in a majority of applications. The National Electrical Code, local electrical codes, special operating temperatures, duty cycles or system configurations will take precedence over the values and methods listed.

Wire Sizes

Unless noted, the wire sizes in this manual are recommended minimums and assume type MTW wire (machine tool wire, 75° C, minimum) per NFPA 79. Since ambient conditions vary widely, on certain applications, a derating factor has to be taken into account. Also, wiring to controllers or motors exceeding 50 feet (15.2 meters) in length (total includes to and from device) may cause excessive voltage drops. Consult the National Electrical Code for factors on ambient conditions, length etc. or the Allen-Bradley Sales Representative in your area for further information.

Shielding

Reasonable care must be taken when connecting and routing power and signal wiring on a machine or system. Radiated noise from nearby relays (relay coils should have surge suppressors), transformers, other electronic drives, etc. may be induced into the velocity command signal lines causing undesired movement of the servomotor.

To help alleviate the problem, machine power and signal lines must be routed separately. The 1391B-ES power and signal lines must be shielded, twisted and routed in separate ferrous metal conduit or harnesses spaced at least 12" (304.8mm) apart. Power leads are defined here as the transformer primary and secondary leads, motor leads and any 115V AC or above control wiring for relays, fans, thermal protectors etc. Signal wiring is defined as velocity command, resolver feedback, enable lines and low level logic signal lines.

Feedback, command signal and other shields must be insulated from each other and connected at a common machine or system earth ground in a "star" fashion (i.e. all shields connected to a single earth ground point). This helps to minimize radiated and induced noise problems and ground loops. Refer to the paragraph entitled "Grounding" and Appendix B.

Open ended shields (resolver feedback cable at the resolver and velocity command cable at the servo controller) must be insulated so that they do not accidentally cause ground loops.

EMI Shielding

The 1391B-ES has an inverter carrier frequency of 2500 Hz. Therefore, the system may induce noise into sensitive equipment lines adjacent to it.



ATTENTION: This controller can produce electromagnetic radiation that may cause industrial or radio controlled equipment to operate erratically and cause possible injury to personnel.

The 1391B-ES system is designed to be interconnected with Allen-Bradley EMI shielded motor cables only. Do Not substitute cables. The EMI shield of the motor cable only, must be grounded at both ends to function properly.

Important: The thermal switch and brake wires are routed near motor power and can pickup PWM radiation. Isolation from control devices may be required.

Grounding

All equipment and components of a machine or process system shall have their chassis connected to a common earth ground point. This ground system provides a low impedance path that helps minimize shock hazards to personnel and damage to equipment caused by short circuits, transient overvoltages and accidental connection of energized conductors to the equipment chassis.

Grounding requirements, conventions and definitions are contained in the National Electrical Code. Local codes will usually dictate what particular rules and regulations are to be followed concerning system safety grounds. See Appendix B.

Wiring



ATTENTION: The National Electrical Code (NEC) and local codes outline provisions for safely installing electrical equipment. Installation must comply with specifications regarding wire types, conductor sizes, branch circuit protection, and disconnect devices. Failure to do so may result in personal injury and/or equipment damage.

The Interconnect Drawing presented in Appendix B provides typical interconnection wiring for the 1391B-ES AC Servo Controller. Typical control logic circuitry (starting and stopping), motor interconnections and grounding techniques are shown.

Motor Wiring

The motor wiring size is determined by the continuous and overload current requirements (RMS Duty Cycle), NEC and local codes. In general, motors operated from the following controllers would not require wire sizes larger than those accepted by TB5, but codes must be followed. In addition, the motor leads must be twisted throughout their entire length to minimize radiated electrical noise. Allen-Bradley 1326 cables must be used. The maximum motor wire sizes that the 1391B-ES controller will accept are shown in Table 6.A.

Table 6.A
Maximum Motor Wire Sizes (TB5)

Controller Catalog Number	Max. Wire Size Accepted
1391B-ESAA15	#8 AWG (8.4 mm ²) – MTW
1391B-ESAA22	#8 AWG (8.4 mm ²) – MTW
1391B-ESAA45	#8 AWG (8.4 mm ²) – MTW

Motor Feedback Wiring

Connections to the integral commutation resolver must be made using an Allen-Bradley 1326-CFUxx shielded cable.



ATTENTION: To guard against hazard of personal injury or damage to equipment, the interconnections to the motor and resolver must be made exactly as shown in Appendix B. Failure to do so could cause loss of motor control and/or severe oscillation of the motor shaft.

Encoder (A Quad B Board) Wiring

Recommended Wire – Belden #9728 or equivalent. Maximum distance between the A Quad B Board and the position controller is 40 feet (12.2 meters) using a 5 volt signal. For distances up to 300 feet (91 meters), 18 AWG wire (0.8 mm²) and an 8 to 15V DC power supply must be used.

For proper operation when interconnecting to IMC products, the B and B (NOT) signals must be reversed.

When interfacing to IMC 121 or 123 controllers, use the 1391-CAQB cable. Refer to Chapter 5 for further information.

Transformer Wiring

The transformer secondary (230V AC, three-phase) connection to the controller is phase insensitive and is shown in Appendix B. The maximum wire size TB5 will accept is 8 AWG (8.4 mm²). Refer to Chapter 9 for the transformer wiring diagrams.

The minimum recommended wire sizes for the transformer secondary are listed below.

Table 6.B
Minimum Transformer Wire Sizes

Input Voltage	kVA					
	1.5	3.5	5.0	10.0	12.5	15.0
208V AC	#12 (3.3)	#12 (3.3)	#12 (3.3)	#8 (8.4)	#8 (8.4)	#6 (8.4)
240V AC	#12 (3.3)	#12 (3.3)	#12 (3.3)	#8 (8.4)	#8 (8.4)	#8 (8.4)
380V AC	#12 (3.3)	#12 (3.3)	#12 (3.3)	#10 (5.3)	#10 (5.3)	#8 (8.4)
415V AC	#12 (3.3)	#12 (3.3)	#12 (3.3)	#12 (3.3)	#10 (5.3)	#10 (5.3)
480V AC	#12 (3.3)	#12 (3.3)	#12 (3.3)	#12 (3.3)	#10 (5.3)	#10 (5.3)
575V AC	#12 (3.3)	#12 (3.3)	#12 (3.3)	#12 (3.3)	#10 (5.3)	#10 (5.3)

Important: All wire sizes are AWG (mm²). The transformer primary requires protection by means of a customer supplied branch circuit disconnect device. Refer to Appendix B2

Fusing (Transformer Primary)

Time delay fusing similar to Bussman Fusetron FRS Series or equivalent must be used if the primary circuit is fused. Circuit breakers must provide equivalent operation.

Fuse ratings shown in Table 6.C are the highest ratings allowed in a 25° C (77° F) ambient temperature. Higher electrical enclosure ambient temperatures will require fuses with higher current ratings. Consult fuse manufacturer's derating data. Fuses larger than those listed below may result in transformer damage.

Table 6.C
Fuse Current Rating (A)

Primary Voltage	kVA					
	1.5	3.5	5.0	10.0	12.5	15.0
208V AC	8	17.5	20	40	50	60
240V AC	7	15	20	35	45	50
380V AC	4.5	9	12	25	30	35
415V AC	4	8	12	20	25	30
480V AC	3.5	7	10	17.5	25	30
575V AC	3	6	8	15	20	25

External Shunt Regulator Resistor

The external Shunt Regulator Resistor and fuse for the 45A 1391B-ES must be connected to TB5-8 and TB5-9 as described in Chapter 9.

22.5A controllers must be converted for use with an external shunt resistor and fuse. Refer to Chapter 9 for detailed instructions.

Interface Connections

Refer to Chapter 5 and Appendix B for connection information.

Motor Option Wiring

Wiring information is provided in Chapter 8 for the Blower Mod and Brake Power Supply kits.

Start-Up

Chapter Objectives

Chapter 7 provides the steps needed to properly start-up the 1391B-ES AC Servo Controller. Included in the procedure are typical adjustments and voltage checks to assure proper operation.

Start-Up Procedure

The following procedure provides the required steps to start-up the 1391B-ES AC Servo Controller in velocity and position mode.



ATTENTION: Power must be applied to the controller to perform many of the adjustments specified in the following paragraphs. Voltages behind the front panel are at incoming line potential. To avoid injury to personnel and/or damage to equipment, only qualified service personnel should perform the following start-up procedures. Thoroughly read and understand the following procedure before beginning the Start-Up Procedure. If an event does not occur while performing this start-up, Do Not Proceed. Remove Power by opening the branch circuit disconnect device and correct the malfunction before continuing.



ATTENTION: This product contains stored energy devices. To avoid hazard of electrical shock, verify that all voltage on the capacitors has been discharged before attempting to service, repair or remove this unit.

Voltage at terminals 9 (+) and 7 (-) of TB5 must be “0.00” as measured with a standard digital voltmeter or multimeter.

Only qualified personnel familiar with solid-state control equipment and safety procedures in publication NFPA 70E should attempt this procedure.

-
- o 1. Assure that all power to the controller is off. Most start-up difficulties are the result of wiring errors. Therefore, prior to applying power to the primary of the transformer or system, check all of the system interconnection wiring.
 - o 2. Check terminal block connections as described in Chapter 5 and Appendix B.

- o 3. Assure that preliminary adjustment of the following items has been performed:
 - Potentiometer adjustments as described in Chapter 5.
 - S1, S2 and SW1 switch settings as described in Chapter 5.

Important: The above adjustments must be performed before proceeding.
- o 4. Assure that the controller circuit breaker (MCB) OFF.
- o 5. Apply power to the transformer, but Do Not enable the controller or energize the line/DB contactor (M).
- o 6. Using a voltmeter, verify that the voltages listed below are present at the locations shown. The tolerance for all voltages is $\pm 10\%$. Clear faults before replacing any blown fuses.

<u>Location</u>	<u>Voltage</u>
TB5-4 to TB5-5	230V AC
TB5-4 to TB5-6	230V AC
TB5-5 to TB5-6	230V AC
TB4-19 to TB4-20	18V AC
TB4-21 to TB4-20	18V AC
TB4-21 to TB4-19	36V AC
TP13 to TP12	+12V DC
TP14 to TP12	-12V DC

- o 7. Remove all power to the transformer.
- o 8. The wires connected to terminals 9 and 10 of TB2 must be marked and removed to allow for local operation of the Enable circuit. Connect a suitable temporary switch between these terminals and insulate the switch connections. See Figure 7.1.

Figure 7.1
Local Control Connections

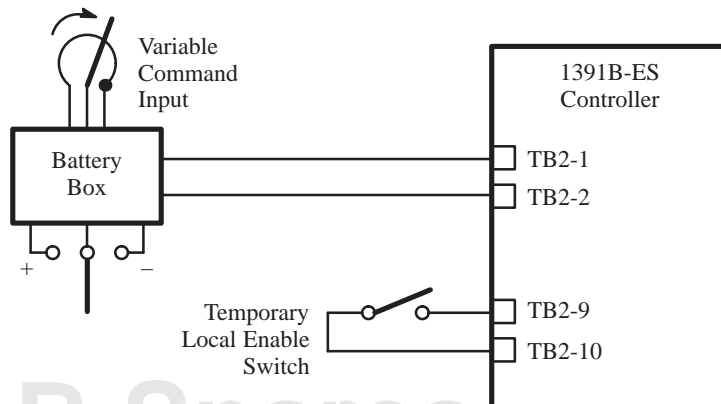

- o 9. The wires connected to terminals 1 & 2 of TB2 (Velocity Command Input) must be marked and removed. A $\pm 10V$ DC local control (battery box) is to be connected to these terminals. See Figure 7.1.

The polarity of the Command signal from the battery box should be the same as the actual control source to assure correct motor rotation when the controller is placed into operation as part of the system.



ATTENTION: Even though the Command SCALE potentiometer is set to zero, the servomotor may begin to rotate and cause incorrect machine movement when the controller is enabled. Be prepared to remove controller power by opening (MCB) or the branch circuit disconnect device if this occurs. This movement may be due to a wiring error or system component malfunction and must be corrected before proceeding with this procedure. Damage to machine system components can occur due to uncontrolled machine movements.

It is recommended that the motor be mechanically disconnected from the load if:

- A) Improper direction of rotation could cause damage to equipment.
- B) Uncontrolled motor rotation due to improper phasing will cause damage to the equipment.

-
- o 10. Once control connections are made:
 - a) Set Command input to zero at the battery box.
 - b) Open Enable switch.
 - c) Apply power to the transformer primary.

Place the circuit breaker (MCB) to the ON position. The green DRIVE READY LED should illuminate.

Important: If power is applied while the controller is enabled, one or more fault LED's will illuminate and disable the controller. The controller may be reset by removing the Enable signal and momentarily grounding the Reset terminal (TB2-11). An alternate method would be to remove and reapply the branch circuit or controller power (36V CT) with the Enable input removed.



ATTENTION: In the following step, reverse rotation or uncontrolled rotation at high speed can occur. To guard against injury, read through the procedure before attempting to start the motor.

- o 11. If adjustable current limit is not desired, proceed to step 12. Ground TB2-5 to TB2-6. Set Current Limit to zero. With a 10% Command input signal applied to terminals 1 and 2 of TB2, momentarily close the local Enable switch and observe motor speed and direction of rotation. The motor should rotate slowly under control (following the Command signal). If the motor is under control but rotating in the wrong direction, reverse the command input signal polarity and note the change on the machine interconnection drawing.

If the motor is uncontrollable, check the feedback wiring at the controller and check for correct phasing of the motor leads. If this does not correct the problem, the position feedback device may be incorrectly phased. Check that the current feedback scaling is set properly and slowly adjust the Current Limit potentiometer (R148) to the maximum clockwise position.

- o 12. Open the Enable switch and branch circuit disconnect.
- o 13. Remove battery box and connect a jumper between terminals 1 and 2 of TB2. Apply power and close the Enable switch. Adjust the Velocity Loop OFFSET potentiometer (R1) to obtain zero rotation of the motor shaft.
- o 14. Open the branch circuit disconnect. Remove jumper and reconnect the wires removed in step 9. Reapply power.
- o 15. On position controlled systems, the position loop gain (system following error) should be set by adjusting the Velocity Command SCALE potentiometer (R132) while commanding various moves from the position controller to achieve desired following error.

On velocity controlled systems (no position loop), the Velocity Command SCALE pot (R132) should be adjusted to give the desired motor speed at the maximum command (reference) voltage.
- o 16. If the proper position loop gain (following error adjustment) or speed cannot be set at maximum motor speed, switch S2-6 may be improperly set (see Chapter 5).
- o 17. **Important:** Before performing this step, ensure that the GAIN pot is set to “4” or below. A setting higher than “4” could cause the motor to vibrate violently.

Adjust the Velocity GAIN potentiometer (R144) and set switch S2-6 as needed. The GAIN adjust pot is used to fine tune the servo system response, switch S2-6 provides varying degrees of response. Setting GAIN at position #4 and placing the switch to “OFF” will give satisfactory response for most applications. If further optimization of the system response is required, the System Compensation Procedure should be followed. If optimization is not required, proceed to step 20.

Figure 7.2
Velocity Response Profiles

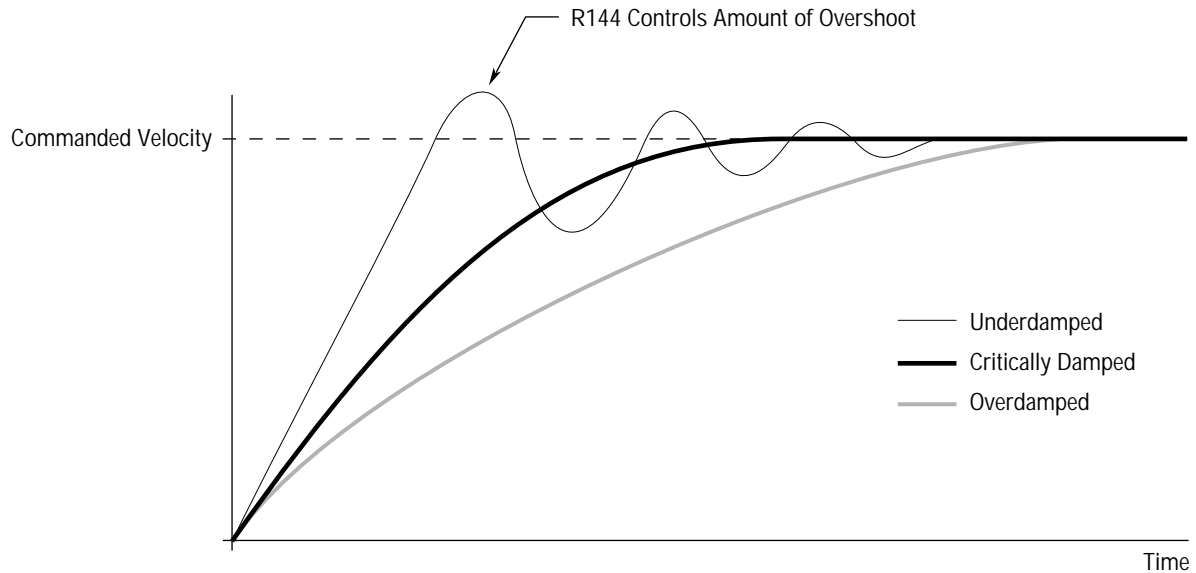

System Compensation Procedure

- o 18. Monitor the velocity feedback signal at terminals 6 (common) and 7 of TB2 with an oscilloscope or chart recorder.



ATTENTION: If an oscilloscope (or chart recorder) is used during Start-Up or Troubleshooting, it must be properly grounded. The oscilloscope chassis may be at a potentially fatal voltage if not properly grounded. Always connect the oscilloscope chassis to earth ground.

When using an oscilloscope (or chart recorder) it is recommended that the test probe ground be connected to TP12.

- o 19. Adjust the Velocity GAIN potentiometer (R144) and observe the velocity response (at TB2-7) profile at various levels of step input speed commands. The “Underdamped” response curve in Figure 7.2 with a single velocity overshoot of 20-30% on accel and decel is optimal on a point to point positioning or velocity controlled system. The “Critically Damped” curve is desirable on a contouring or metal removing system.

The GAIN pot should be adjusted so that the motor achieves the commanded speed or final position as quickly as possible with no overshoot. In addition to the dynamic response, the motor shaft should not oscillate or exhibit any erratic motion at zero speed.

- o 20. Remove power with the branch circuit disconnect.
- o 21. Remove the local Enable switch and reconnect external wiring.
- o 22. Apply power and check system operation.
- o 23. Remove power with the branch circuit disconnect and if necessary, reconnect motor to load.

The 1326 AC Servomotor

Chapter Objectives

Chapter 8 describes the operation of a standard 1326 AC Servomotor with the enhanced capabilities of a Bulletin 1391B-ES AC Servo Controller. Refer to the *1326 AC Servomotor Product Data* for further information on Allen-Bradley AC Servomotors.

Introduction

The 1391B-ES provides additional energy to the 1326 motor, allowing it to operate at higher speeds without a reduction of torque.

In general, the 1326 motor will follow the speed–torque curve shown in Figure 8.2

Figure 8.2
Typical Bulletin 1326 Speed–Torque Curve

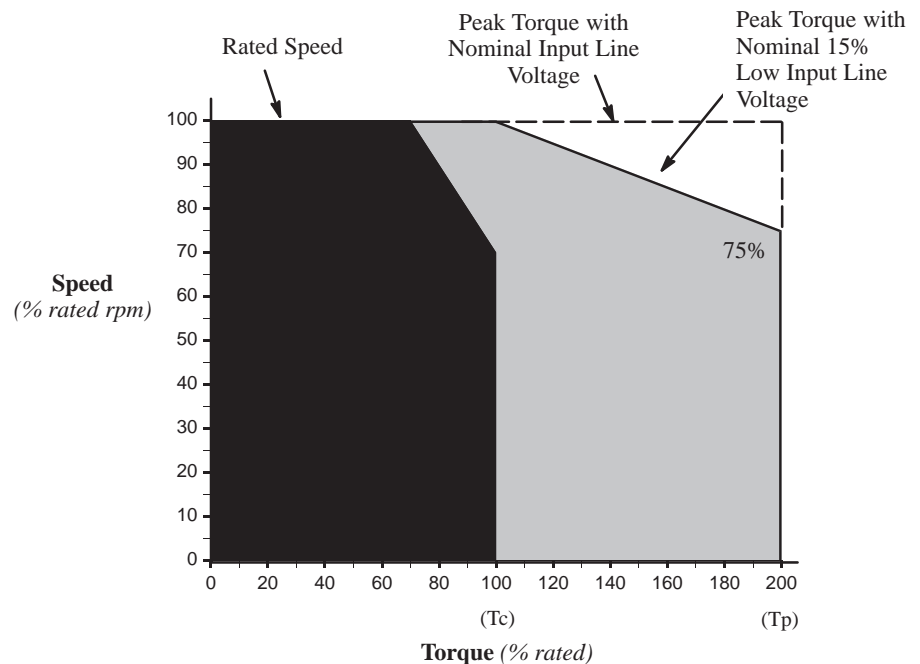

Tc – rated torque of motor with windings at rated temperature and an ambient of 40°C. The controller is operating in a rated ambient of 60°C.

T_p – the peak torque that can be produced by the motor/controller combination with both at rated temperature and the motor in a 40°C ambient and the controller in a 60°C ambient. Since 200% current torque peaks are common in many applications for optimal controller usage, the following curves show typical system performance. Higher peak torques are permissible where RMS torque is less than or equal to the rated torque (T_c). 1391B-ES operation is shown in the outer envelope and will show higher speed and 300% torque capability.

Rated Speed – the operating speed of the controller and motor combination at which a minimum of 70% of continuous rated torque (T_c) can be developed. This point is defined with the motor at 25°C and controller operating in a 60°C ambient.

Rated Operation Area – boundary of speed-torque curve where the motor and controller combination may operate on a servo basis without exceeding the RMS rating of either.

Duty Cycle Profile

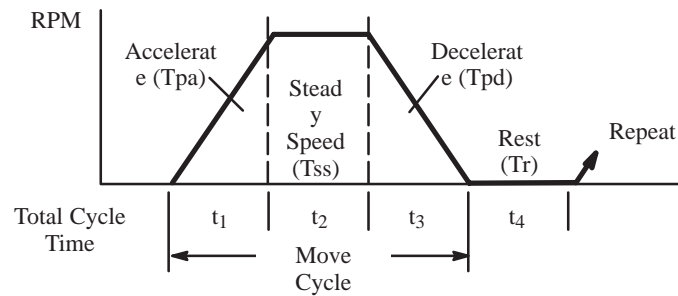

$$T_{rms} = \sqrt{\frac{T_{pa}^2 \times t_1 + T_{ss}^2 \times t_2 + T_{pd}^2 \times t_3 + T_r^2 \times t_4}{t_1 + t_2 + t_3 + t_4}}$$

where:

$$t_1 + t_2 + t_3 + t_4$$

- T_{rms} The motors RMS or average torque over the duty cycle. (Expressed in lb.-in. or lb.-ft. The same units must be used throughout the formula.)
- T_{pa} Motor peak torque to accelerate to maximum speed. (Expressed in lb.-in. or lb.-ft. The same units must be used throughout the formula.)
- T_{ss} Motor torque present at the motor shaft during constant speed segment. (Expressed in lb.-in. or lb.-ft. The same units must be used throughout the formula.)
- T_{pd} Motor peak torque to decelerate to zero speed. (Expressed in lb.-in. or lb.-ft. The same units must be used throughout the formula.)
- T_r Torque when motor is at zero speed (typically is T_{ss}).
- t₁, t₂, t₃, t₄ Time for each portion of the duty cycle in seconds.

Intermittent Operation Area – Boundary of speed-torque curve where the motor and controller combination may operate in acceleration-deceleration mode without exceeding peak rating of either, provided that the duty cycle RMS continuous torque limit is not exceeded.

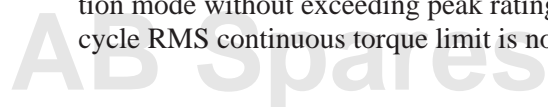

Table 8.A provides a comparison of the resultant speed obtained from standard Bulletin 1326 servomotors using Bulletin 1391 and Bulletin 1391B–ES Servo Controllers.

Table 8.B
1391/1391B-ES Speed Comparison

Continuous Stall Torque (lb.-in./N-m)	Peak Stall Torque (lb.-in./N-m)	Rated Speed (rpm)	Motor Catalog Number	Servo Amplifier Catalog Number	Amperes at Continuous Torque	Rotor Inertia (lb.-in.-s ² /kg-m ²)	Rated Output (kW)
	48/5.4	6000	1326AB-A1G			0.004/0.0005	0.9
16/1.8	96/10.84	4000	1326AB-A2E	1391B-AA15	4.5	0.007/0.0008	1.1
32/3.6	144/16.3	4000	1326AB-A3E	1391B-AA15	5.2	0.010/0.001	1.6
48/5.4	170.7/19.3	4000	1326AB-B2E	1391B-AA15	7.8	0.05/0.006	3.0
93.3/10.53	279/31.5	4000	1326AB-B2E	1391B-AA15	15.0	0.05/0.006	3.3
102/11.5	280/31.6	4000	1326AB-B3E	1391B-AA22	16.4	0.08/0.009	4.7
140/15.8	459/51.9	4000	1326AB-B3E	1391B-AA22	22.5	0.08/0.009	5.1
153/17.3	569/64.3	4000	1326AB-C2E	1391B-AA45	24.6	0.14/0.015	6.9
210/23.7	568/64.1	3000	1326AB-C3E	1391B-AA45	33.2	0.22/0.024	10.0
310/35.0	811/91.7	2000	1326AB-C4C	1391B-AA45	49.1	0.29/0.032	9.3 ³
420/47.4	989/111.8		1326AB-C4B	1391B-AA45	46.6	0.29/0.032	7.5

¹ All ratings are for 40° C motor ambient, 110° C case and 60° C amplifier ambient. For extended ratings at lower ambients contact Allen-Bradley.

² The motor contains two thermal switches wired in series that will open on an overtemperature condition. They are set to open at 150° C (typical) and close at 90-100° C (typical). Contacts are rated for 1A at 115V AC, 1A at 24V DC.

³ -10% line voltage maximum.

Motor Options/Accessories

For detailed motor option/accessory information, refer to the individual instruction sheets shipped with the option/accessory.

End of Chapter

AB Spares

Transformers and Shunt Regulators

Chapter Objectives

Chapter 9 provides general information about the 1391 Isolation Transformer. In addition, shunt regulator information is also provided.

1391 Transformers

The 1391B-ES must operate from an isolation transformer having a three-phase, 230V AC output and a single-phase, 36V AC output.

Transformers supplied with the 1391B-ES can provide power for up to four controllers. Standard three-phase input voltages for the 60 Hz units are available. The kVA values specified are the continuous outputs of the units in a 60° C ambient.

Important: The maximum rating that can be connected to the 1391B-ES is 15 kVA.

Important: The 1391B-ES controller uses a phase sensitive 36V AC transformer tap to provide power to the Logic Control Board. It is recommended that a 1391 Isolation Transformer be used. Contact your local Allen-Bradley Sales Representative if a transformer of a different type must be used. Refer to Figure 9.1 and Appendix B for connection information.



ATTENTION: Damage to the controller will result if the center tap wire (Y2, Y5, Y8, Y11) shown in Figure 9.1 is not connected to TB4-20 as shown in Appendix B.

60 Hz Transformers

Two 60 Hz transformers are available and have input ratings of:

1. 240/480V AC , three-phase
2. 208/230/460/575V AC, three-phase

50/60 Hz Transformers

The 50/60 Hz transformer that is available has an input rating of 240/380/415/480V AC, three-phase.

NEMA Type 1 Enclosure

Dimensions for the NEMA Type 1 enclosures are shown in Appendix A.

Important: The NEMA Type 1 enclosure is shipped as a kit for customer assembly.

If other input voltages or special enclosures are required, consult your local Allen-Bradley Sales Representative. Refer to Figure 9.1 for connection information and Appendix A for dimensions.

Figure 9.1
1391 Transformer Wiring Diagrams

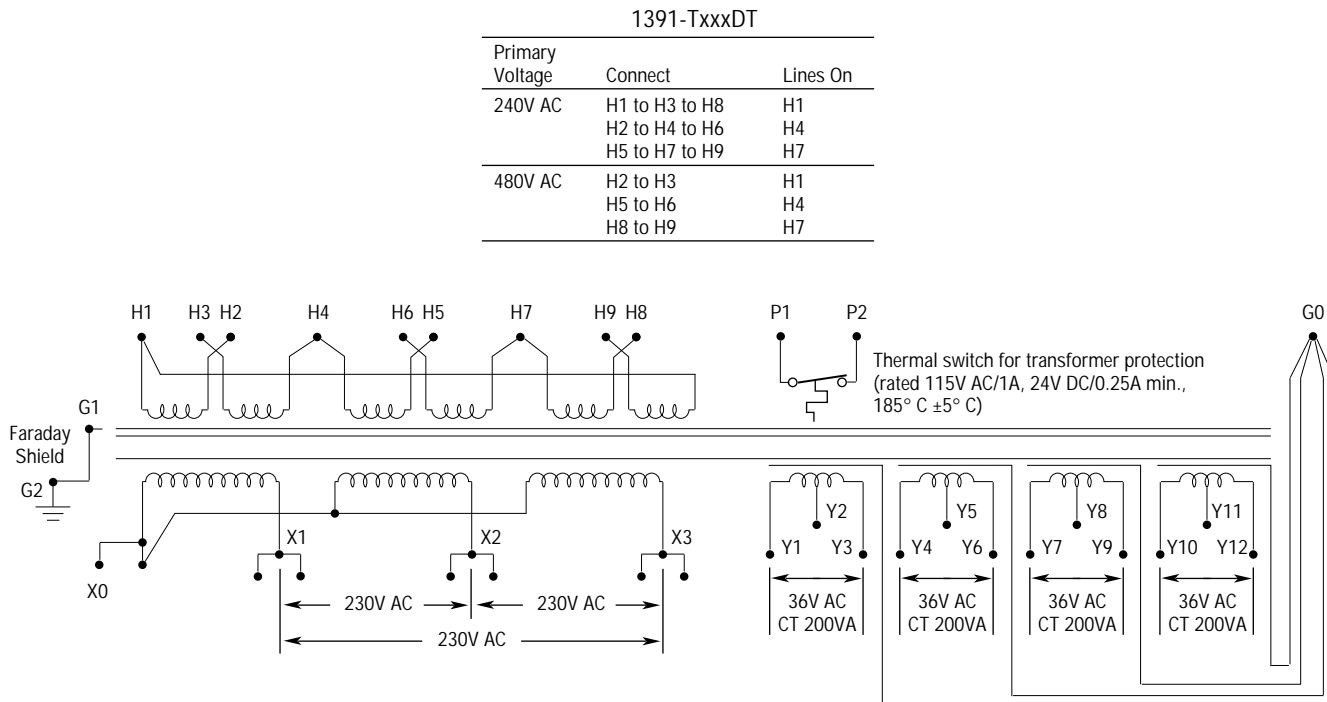

1391-TxxxET

Primary Voltage	Connect	Lines On
240V AC	H2 to H6	
	H7 to H11	
	H12 to H1	
380V AC	H3 to H6	H1
	H8 to H11	H6
	H13 to H1	H11
415V AC	H4 to H6	
	H9 to H11	
	H14 to H1	
480V AC	H5 to H6	
	H10 to H11	
	H15 to H1	

1391-TxxxNT

Primary Voltage	Connect	Lines On
208V AC	H2 to H6	
	H7 to H11	
	H12 to H1	
240V AC	H3 to H6	H1
	H8 to H11	H6
	H13 to H1	H11
480V AC	H4 to H6	
	H9 to H11	
	H14 to H1	
575V AC	H5 to H6	
	H10 to H11	
	H15 to H1	

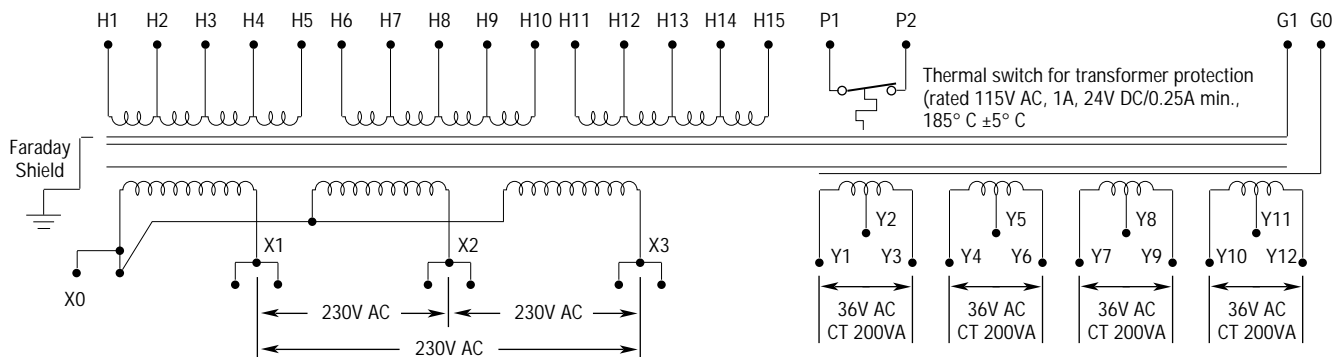

Shunt Regulator Operation

Refer to Chapter 4 for an explanation of the shunt regulator circuitry. The nominal data for the shunt regulator is as follows:

- Overvoltage Trip Point = 405V DC±2.5%
- DC Bus Shunt “ON” Point = 386.4V DC
- DC Bus Shunt “OFF” Point = 366.9V DC
- Nominal DC Bus Voltage = 300V DC
- DC Bus Undervoltage Detect = 145V DC±20%

The shunt regulator behavior is modified by an adjustable duty cycle timer. The timer is used to model the shunt resistor temperature. A selector switch (SW1) determines the temperature level and therefore the average power level at which the controller will fault. When this level is reached, the controller will be forced to fault on an overvoltage. This action would be equivalent to turning the shunt regulator off.

The Duty Cycle Selector Switch is located on top of the controller near terminal Block, TB5 (see Figure 1.1). The switch has 16 positions designated “0 to F,” with “0” being the lowest value and “F” the highest. The higher the setting, the higher the average power seen by the shunt resistor. The Duty Cycle Selector Switch settings for various controller/shunt combinations are shown in Tables 9.A and B.

Important: Accurate operation of the Duty Cycle Timer is dependent on the shunt resistor value. Do Not substitute alternate values.

Table 9.A provides the required Duty Cycle Selector Switch settings and resistor power trip points for factory supplied configurations. An optional external resistor assembly (catalog number 1391-MOD-SR22A) is available for the 22.5A 1391B-ES.

Table 9.A
Maximum Switch Settings and Trip Points for Factory Supplied Configurations

Configuration	SW1 Switch Setting	Nominal Trip Point
1391B-ESAA15 w/ standard 16 ohm internal resistor	B*	164w, ±10%
1391B-ESAA22 w/ standard 12 ohm internal resistor	B*	162w, ±10%
1391B-ESAA22 w/ 9 ohm external resistor (1391-MOD-SR22A)	F	386w, ±10%
1391B-ESAA45 w/ standard 5 ohm external resistor	D*	715w, ±10%

* Denotes SW1 setting at time of shipment. User must reconfigure controller when using optional 1391-MOD-SR22A.



ATTENTION: The designated settings for the factory supplied configurations must be used or damage to the controller may result.

Table 9.B shows the nominal resistor power trip levels in watts for the various switch settings. When shunt requirements exceed the selector setting, the excess power will cause the bus voltage to rise, resulting in an overvoltage fault condition.

Table 9.B
Nominal Power Trip Level Reference Data (continuous watts,±10%)*

SW1 Switch Setting	15A W/ Int. 16 Ohm Resis- tor	22.5A W/ Int. 12 Ohm Resis- tor	22.5A W/ Ext. 9 Ohm Resis- tor	45A W/ Ext. 5 Ohm Resis- tor
0	67	73	98	215
1	71	77	103	227
2	75	82	109	241
3	80	86	115	256
4	85	92	122	274
5	91	98	130	294
6	99	105	139	317
7	107	113	150	344
8	118	122	163	378
9	130	133	177	417
A	145	146	195	466
B	164*	162*	216	527
C	189	183	243	607
D	223	208	277	715*
E	272	242	323	872
F	347	290	386*	1115

* Denotes the maximum allowable settings for factory supplied configurations.



ATTENTION: To guard against personal injury and/or equipment damage from an overheated resistor, the designated duty cycle settings for factory supplied shunt resistor configurations must not be exceeded. Check the Duty Cycle Selector Switch (SW1) to ensure that it is set properly before operation.



ATTENTION: When using a customer supplied external shunt resistor assembly, the Duty Cycle Selector Switch (SW1) must be set to an appropriate level for that resistor assembly. Consult the resistor manufacturer for the appropriate derating guidelines. Failure to comply could result in personal injury and/or equipment damage from an overheated resistor.

Frequent overvoltage trips on high inertia systems (load is 2 or 3 times the motor inertia) during regenerative states (deceleration) may be an indication that an external shunt resistor having increased power dissipation capacity is required. Based on the data supplied, Allen-Bradley will specify a shunt resistor with the proper resistance value for the controller being used.

Shunt Regulator Installation

External Shunt Resistors

The 1391B-ES is designed to allow the use of an external shunt resistor on the 22.5 and 45A units. To use an external shunt resistor with the 22.5A units, the user must reconfigure the controller at terminal block TB5.

The following steps provide the information needed to properly convert 22.5A controllers for use with an external shunt resistor and fuse. Refer to the resistor and fuse mounting dimensions provided in Appendix A and the Interconnect Diagram in Appendix B, as required.



ATTENTION: To guard against an electrical shock hazard, ensure that all power to the controller has been removed prior to performing the following procedure and the bus voltage at terminal 9 (+) and 7 (-) of TB5 measures 0.00 volts.

24. Remove and discard the jumper present between terminals 8 and 10 of TB5. This disconnects the internal shunt resistor and fuse from the shunt regulator circuit.
-



ATTENTION: When using an external shunt resistor assembly with the 22.5A 1391B-ES, ensure that the internal resistor assembly has been disconnected per the above instructions. Personal injury and/or equipment damage could result from an overheated resistor if the internal resistor is not disconnected.

25. Connect one end of the new external shunt fuse to terminal 9 of TB5. Connect the other end of the fuse to one end of the shunt resistor.

Important: The external shunt resistor must have a fuse in series with the shunt resistor. Refer to the paragraph entitled “Shunt Fusing” for more information.

26. Connect the remaining end of the shunt resistor to terminal 8 of TB5.
27. Using Table 9.B, set the Duty Cycle Selector Switch to the appropriate setting for the resistor being used.
28. Install the appropriate shunt fuse in its holder.



ATTENTION: Proper derating must be applied to the manufacturers nominal resistor power ratings when using these in external shunt configurations. Consult the resistor manufacturer for recommended derating. Failure to comply could result in personal injury and/or equipment damage from an overheated resistor.

Shunt Fusing

Shunt regulator fusing is provided with all of the 1391B-ES controllers. The fuse is in series with the resistor and used to protect the resistor against short circuits. The shunt fuse is located on top of the controller near the circuit breaker for 15 and 22.5A controllers. External resistors for 22.5A and 45A controllers are supplied with a fuse which must be mounted external to the controller (see Appendix A for mounting dimensions). Refer to Table 9.C for further shunt fuse information.

Table 9.C
Shunt Fuse Information

Controller Rating	Fuse Location	Fuse Type
15A	Top Panel	Buss KLM-10 or equivalent
22.5A	Top Panel	Buss FNM-6.25 or equivalent
22.5A	External	Buss KTK-15 or equivalent
45A	External	Buss KLM-20 or equivalent

Important: Repeated overvoltage tripping can be an indication that the shunt fuse has malfunctioned.

End of Chapter

AB Spares

Troubleshooting

Chapter Objectives

Chapter 10 provides information to guide the user in troubleshooting the 1391B-ES. Included in the chapter are LED descriptions and fault diagnosis, general system troubleshooting and test point descriptions.

System Troubleshooting

Most controller faults are annunciated by the LED diagnostic indicators on the front of the controller. Many system malfunctions manifest themselves through a controller fault. The use of LED indications may aid in identifying servo controller and motor malfunctions.

Table 10.A provides a listing and description of the LED indicators. In addition, potential causes are listed.

Tables 10.B and 10.C provide a number of common system and servomotor malfunctions and their possible causes.

Table 10.D provides a listing and description of the 1391B-ES test points.



ATTENTION: This product contains stored energy devices. To avoid hazard of electrical shock, verify that all voltage on the capacitors has been discharged before attempting to service, repair or remove this unit.

Voltage at terminals 9 (+) and 7 (–) of TB5 must be “0.00” as measured with a standard digital voltmeter or multimeter.

Only qualified personnel familiar with solid-state control equipment and safety procedures in publication NFPA 70E should attempt this procedure.

Table 10.A
LED Descriptions and Fault Diagnosis

LED	LED Description	Potential Cause
OVERTEMPERATURE (RED)	The controller contains a thermal switch on the heat sink which senses the power transistor temperature. If the temperature is exceeded the LED will illuminate.	<p>OVERTEMPERATURE LED is Illuminated</p> <p>The logic supply ($\pm 12V$ DC, $+5V$ DC) circuits have malfunctioned (fuse blown etc.) or the AC input at TB4-19, 20, 21 is incorrectly wired.</p> <p>The heat sink thermal overload has tripped. One or more of the following may have occurred:</p> <ol style="list-style-type: none"> 1. The cabinet ambient temperature is above rating. 2. The machine duty cycle requires an RMS current exceeding the continuous rating of the controller. 3. The integral fan is not functioning. 4. The airflow access to the controller is limited or blocked.
POWER FAULT (RED)	The current through the power output transistors is monitored. If the current exceeds a fixed level (greater than 300% of controller rating) the LED will illuminate.	<p>POWER FAULT LED is Illuminated</p> <ol style="list-style-type: none"> 1. The current through any one of the power transistors has exceeded 300% of the controller's current rating. 2. Malfunctioning power transistor. 3. Shorted Lead. 4. Winding to case motor capacitance is out of tolerance.
CONTROL (POWER) FAULT (RED)	A fault will occur and the LED will illuminate, if: <ol style="list-style-type: none"> 1. The logic supply rises or drops 10% from its nominal value or 2. The resolver wiring is open or shorted. 	<p>CONTROL (POWER) FAULT LED is illuminated</p> <ol style="list-style-type: none"> 1. Open or short circuit on resolver wiring. 2. The input line voltage is out of tolerance. 2. The transformer auxiliary logic supply winding is open. 3. The logic supply ($\pm 12V$ DC, $+5V$ DC) circuits have malfunctioned (fuse blown etc.) or the AC input at TB4-19, 20, 21 is incorrectly wired.
OVERVOLTAGE (RED)	The DC Power Bus is continuously monitored. If it exceeds a preset level a fault is sensed, the power supply is disabled and the LED is illuminated.	<p>OVERVOLTAGE LED is illuminated</p> <p>The logic supply ($\pm 12V$ DC, $+5V$ DC) circuits have malfunctioned (fuse blown etc.) or the AC input at TB4-19, 20, 21 is incorrectly wired.</p> <p><u>The power bus voltage has exceeded 405V DC.</u></p> <ol style="list-style-type: none"> 1. Logic Board is malfunctioning and incorrectly sensing the bus voltage. 2. A vertical axis with insufficient counterbalancing is overdriving the servomotor and causing excessive energy to be returned to the power supply bus. 3. The system inertia is too high causing excessive energy to be returned to the power supply bus. 4. Input line voltage exceeds the maximum controller input voltage rating. 5. The position controller acceleration / deceleration rate is incorrectly set. 6. The shunt regulator or transistor has malfunctioned.
UNDERVOLTAGE (YELLOW)	If the DC Power Bus drops below a preset level, a fault occurs and the LED is illuminated.	<p>UNDERVOLTAGE LED is illuminated</p> <p><u>Shunt regulator fuse has blown.</u></p> <p><u>Shunt regulator or resistor not connected to controller.</u></p> <p><u>The power bus voltage has dropped below a preset DC value</u></p> <ol style="list-style-type: none"> 1. The power contactor (M) has not energized or has dropped out. 2. The input line voltage is low. 3. The shunt regulator circuit has malfunctioned and is placing the shunt resistor across the power bus. 4. The power bus capacitor has malfunctioned. 5. The circuit breaker (MCB) has tripped. 6. The three-phase input line is open. 7. Transformer is supplying the wrong line voltage or has malfunctioned.

Table 10.A
LED Descriptions and Fault Diagnosis (*Continued*)

LED	LED Description	Potential Cause
UNDERVOLTAGE (Continued)		<p><u>The logic supplies have dropped 10% below their nominal value</u></p> <ol style="list-style-type: none"> 1. The input line voltage is out of tolerance. 2. The transformer auxiliary logic supply winding is open. 3. The logic supply ($\pm 12V$ DC, +5V DC) circuits have malfunctioned (fuse blown etc.) or the AC input at TB4-19, 20, 21 is incorrectly wired.
CURRENT FOLD-BACK (YELLOW)	The CURRENT FOLDBACK LED illuminates when the Current Foldback circuitry is operating.	<p>CURRENT FOLDBACK LED is illuminated</p> <p>The logic supply ($\pm 12V$ DC) circuits have malfunctioned (fuse blown etc.) or the AC input at TB4-19, 20, 21 is incorrectly wired.</p> <p><u>The output current is exceeding its time-current rating</u></p> <ol style="list-style-type: none"> 1. The acceleration/deceleration command from the position controller is requiring peak current for an excessive amount of time. 2. The Gain pot is set too high causing excessive peak currents. 3. The machine friction, inertial load and/or viscous loading is excessive. 4. The servomotor has been improperly sized. 5. A short circuit exists across the controller output terminals.
RUN ENABLE (GREEN)	The application of an Enable signal by the machine position controller will cause the RUN ENABLE LED to illuminate.	<p>ENABLE LED is NOT Illuminated</p> <ol style="list-style-type: none"> 1. The position controller has not enabled the controller. 2. The Enable wiring to the controller is open. 3. The position controller Enable relay/switch has malfunctioned. 4. The position controller has detected a machine system malfunction that will not allow the controllers to be Enabled. 5. Power has not been applied to input transformer. 6. The logic supply ($\pm 12V$ DC) circuits have malfunctioned (fuse blown etc.) or the AC input at TB4-19, 20, 21 is incorrectly wired. <p>ENABLE LED is Illuminated, but Controller does not Enable</p> <ol style="list-style-type: none"> 1. A controller malfunction has occurred but is not annunciated by the LED indicators. Check the status of the Drive OK output (DROK) relay. 2. A component malfunction exists in the Enable circuit. 3. The circuit breaker (MCB) is tripped. 4. The power contactor has not been energized or has malfunctioned. <p><u>The controller logic supplies are not operational</u></p> <ol style="list-style-type: none"> 1. The logic supply fuses are blown 2. Logic supply AC voltage is missing 3. A controller malfunction has occurred but is not annunciated by the LED indicators (check the status of the Drive OK contacts).
DRIVE READY (GREEN)	This LED is continuously illuminated until a system fault occurs.	<p>DRIVE READY LED is NOT illuminated</p> <ol style="list-style-type: none"> 1. System fault has occurred.

Table 10.B
 General System Troubleshooting

Condition	Possible Cause
Axis or System runs uncontrollably	<ol style="list-style-type: none"> 1. The velocity feedback, position feedback device or velocity command signal wiring is incorrect or open. 2. An internal controller malfunction exists.
Axis or System is unstable	<ol style="list-style-type: none"> 1. Velocity Loop Compensation or Gain potentiometer is incorrectly set. 2. Position Loop Gain or Position Controller accel/decel rate is improperly set. 3. Improper grounding or shielding techniques are causing noise to be transmitted into the position feedback or velocity command lines, causing erratic axis movement.
Desired motor acceleration / deceleration cannot be obtained	<ol style="list-style-type: none"> 1. The Current Limit pot is incorrectly set. 2. The Current Feedback Scaling is incorrect. 3. The system inertia is excessive. 4. The system friction torque is excessive. 5. Available controller current is insufficient to supply the correct accel/decel rate.
Motor does not respond to a Velocity Command	<ol style="list-style-type: none"> 1. The controller has a malfunction 2. The controller is not enabled. 3. The power contactor is not energized. 4. Power transformer is supplying the incorrect voltage or none at all. 5. The motor wiring is open. 6. The motor or transformer thermal overload has tripped. 7. The motor has malfunctioned. 8. The motor coupling has malfunctioned. 9. The feedback circuit (motor to controller) is open.
Presence of noise on Command or resolver signal wires	<ol style="list-style-type: none"> 1. 60 Hz line frequency may be present. 2. 120 Hz from a single phase logic supply may be present. 3. 180 or 360 Hz from other adjustable speed drives may be present. 4. Variable frequency (varies with motor speed) may be velocity feedback ripple or a disturbance caused by gear teeth or ballscrew balls etc. The frequency may be a multiple of the motor power transmission components or ballscrew speeds. 5. Recommended grounding per Appendix B has not been followed.

Table 10.C
General Servomotor Troubleshooting

Condition	Possible Cause
No Rotation	<ol style="list-style-type: none"> 1. The motor connections are loose or open. 2. Foreign matter is lodged in the motor. 3. The motor load is excessive. 4. The bearings are worn.
Overheating	<ol style="list-style-type: none"> 1. The rotor is partially demagnetized causing excessive motor current. 2. Motor voltage is exceeding the maximum value. 3. The duty cycle is excessive.
Abnormal Noise	<ol style="list-style-type: none"> 1. Loose parts are present in the motor. 2. Through bolts are loose. 3. The bearings are worn. 4. GAIN setting is too high.
Erratic Operation - Motor locks into position, runs without control or with reduced torque	<ol style="list-style-type: none"> 1. Phases A & B, A & C or B & C reversed 2. Sine, Cosine or Rotor leads reversed 3. Sine, Cosine, Rotor lead sets reversed 4. Combinations of 1, 2, 3

Test Point Descriptions

Table 10.D describes the various test points found in the 1391B-ES controller. Refer to Figure 10.1 for test point locations.

Table 10.D
Test Point Descriptions

Test Point	Description
TP2	Resolver Amplitude (6.5V p-p sine wave at 9.3 kHz, 2.3V RMS)
TP3	Tachometer Output (2.0V/krpm or 1.2V/krpm)
TP6	I_D (adjust using R45)
TP7	PWM Triangle (2.5 kHz, 11Vp-p)
TP8	PWM B
TP9	PWM A
TP10	PWM C
TP11	+5V DC
TP12	Signal Common
TP13	+12V DC
TP14	-12V DC
TP15	I_B Reference
TP16	I_A Reference
TP17	$ I $ Absolute Value
TP19	Buffered Velocity Command
TP21	Current Limit Calibration (adjust with R148, 3V DC=Rated Motor Current – TB2-5 Must be Grounded)
TP22	Current Command (3V DC=Rated Motor Current)
TP29	Current Feedback (Phase B, 2.5V Peak=Rated Motor Current)
TP30	Current Feedback (Phase A, 2.5V Peak=Rated Motor Current)
TP31	Regen I Limit (3.0V DC=Rated Motor Current)

Figure 10.1
Logic Control Board Test Point Locations

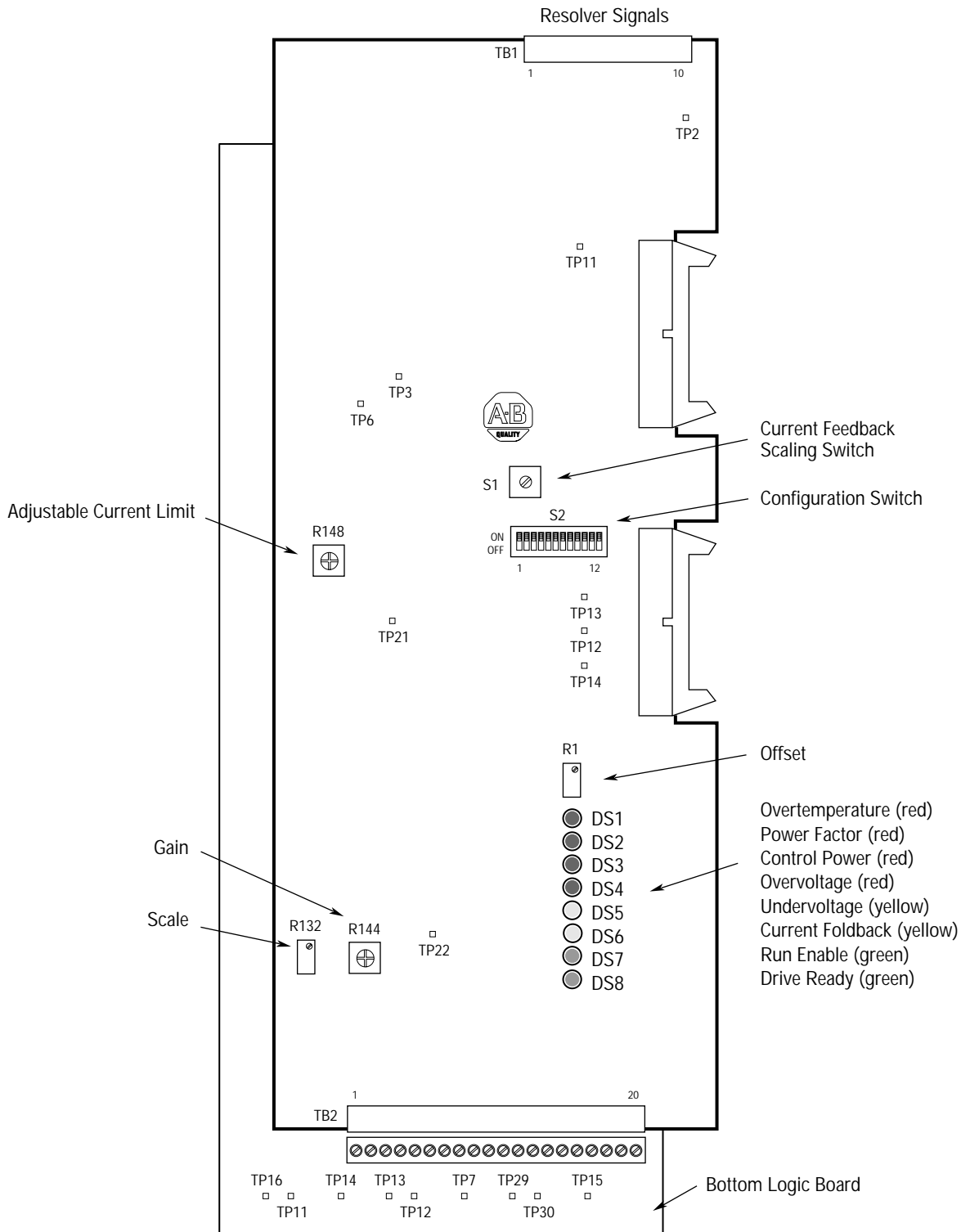

AB Spares

Figure 10.2
1391B-ES Top Panel

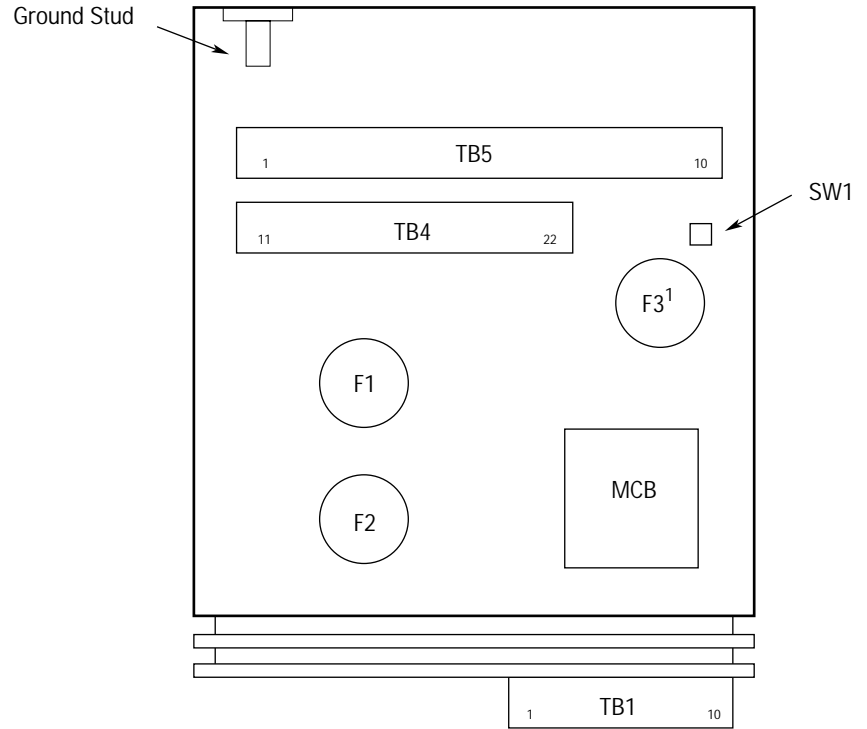

¹ F3 provided on 15 and 22.5A units only.
15A = KLM-10
22.5 = FNO 6 1/4 series B only

End of Chapter

AB Spares

Dimensions

Figure A.1
1391B-ES Dimensions
Dimensions are in inches and (millimeters)

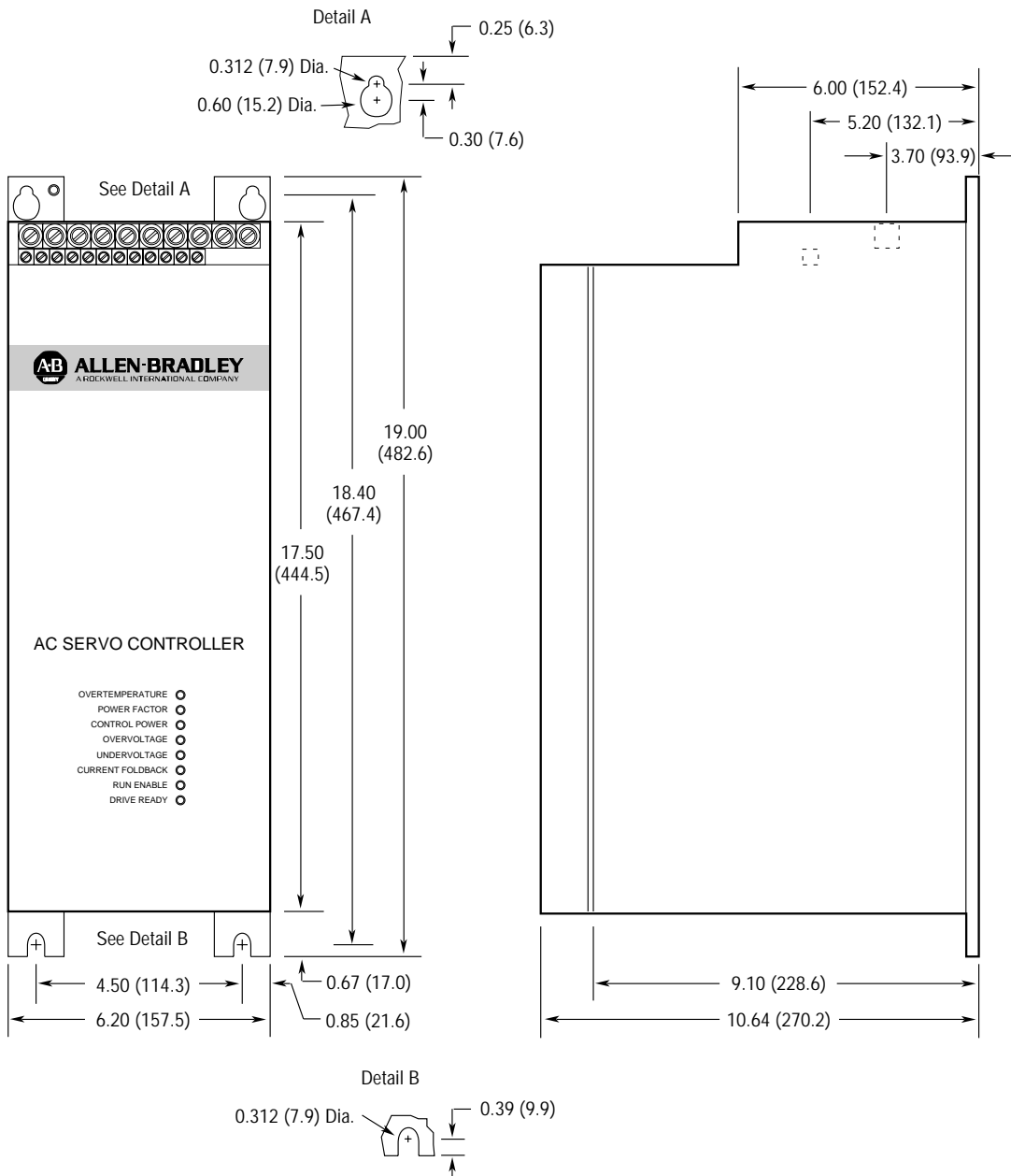

Notes:

1. Mounting slots and keyholes will accept 1/4-20 (7 mm) hardware.
2. A minimum spacing of 0.312" (7.9 mm) is required between adjacent controllers - 1" (25.4 mm) is recommended.

Figure A.2
1391 Isolation Transformer Dimensions
Dimensions are in inches and (millimeters)

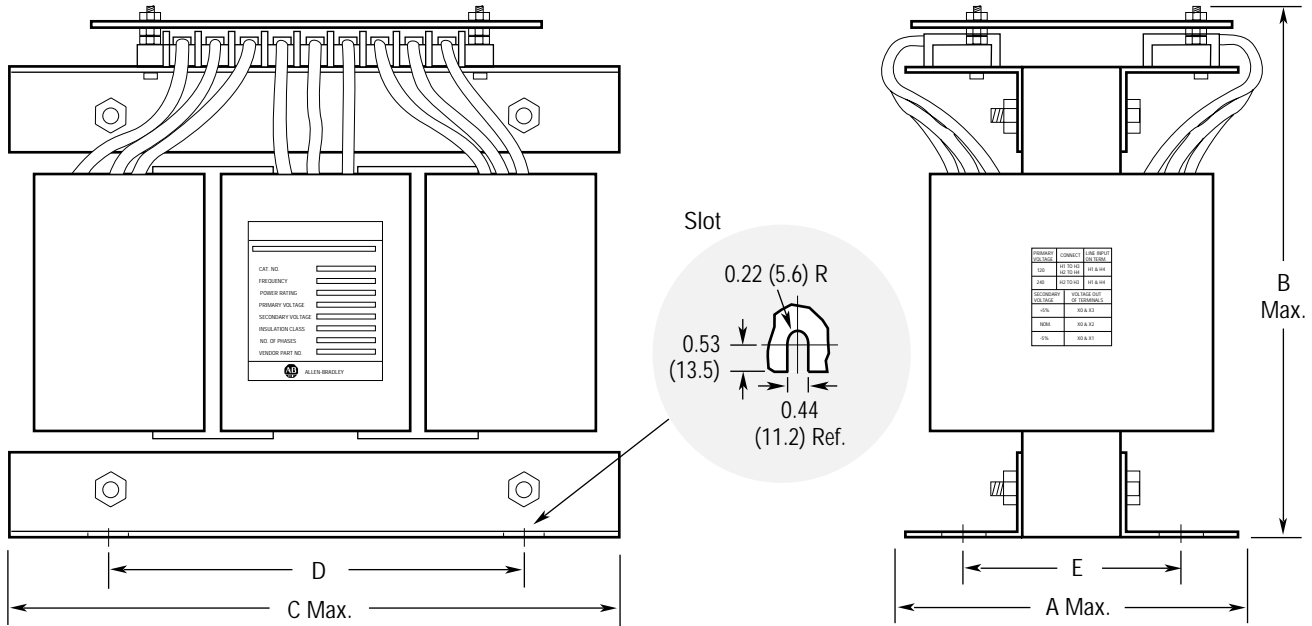

Catalog Number	kVA	A	B	C	D	E	Weight
1391-T015DT	1.5	9.00 (228)	10.00 (254)	13.00 (330)	5.00 (127)	3.10 (79)	27 (12.2)
1391-T015ET/ NT		9.00 (228)	10.00 (254)	13.00 (330)	5.00 (127)	3.50 (89)	40 (18.2)
1391-T025DT	2.5	11.00 (279)	11.00 (279)	14.00 (356)	6.00 (152)	3.30 (84)	42 (19.0)
1391-T025ET		11.00 (279)	11.00 (279)	14.00 (356)	6.00 (152)	4.00 (102)	60 (27.2)
1391-T035DT	3.5	11.00 (279)	11.00 (279)	14.00 (356)	6.00 (152)	4.50 (114)	60 (27.2)
1391-T035NT		11.00 (279)	11.00 (279)	14.00 (356)	6.00 (152)	4.50 (114)	85 (38.6)
1391-T050DT	5.0	11.00 (279)	11.00 (279)	14.00 (356)	6.00 (152)	5.25 (133)	75 (34.0)
1391-T050ET/ NT		11.00 (279)	11.00 (279)	14.00 (356)	6.00 (152)	6.00 (152)	100 (45.4)
1391-T100DT	10.0	12.00 (305)	12.50 (317)	16.00 (406)	8.00 (203)	5.85 (149)	112 (50.8)
1391-T100ET/ NT		12.00 (305)	12.50 (317)	16.00 (406)	8.00 (203)	5.85 (149)	140 (63.6)
1391-T125DT	12.5	12.00 (305)	12.50 (317)	16.00 (406)	8.00 (203)	5.63 (143)	126 (57.1)
1391-T125ET/ NT		12.00 (305)	12.50 (317)	16.00 (406)	8.00 (203)	5.63 (143)	160 (72.7)
1391-T150DT	15.0	13.00 (330)	14.00 (356)	17.50 (444)	9.50 (241)	6.00 (152)	150 (68.0)
1391-T150ET/ NT		13.00 (330)	14.00 (356)	17.50 (444)	9.50 (241)	6.00 (152)	200 (90.9)

Figure A.3
NEMA Type 1 Enclosure Dimensions
Dimensions are in inches and (millimeters)

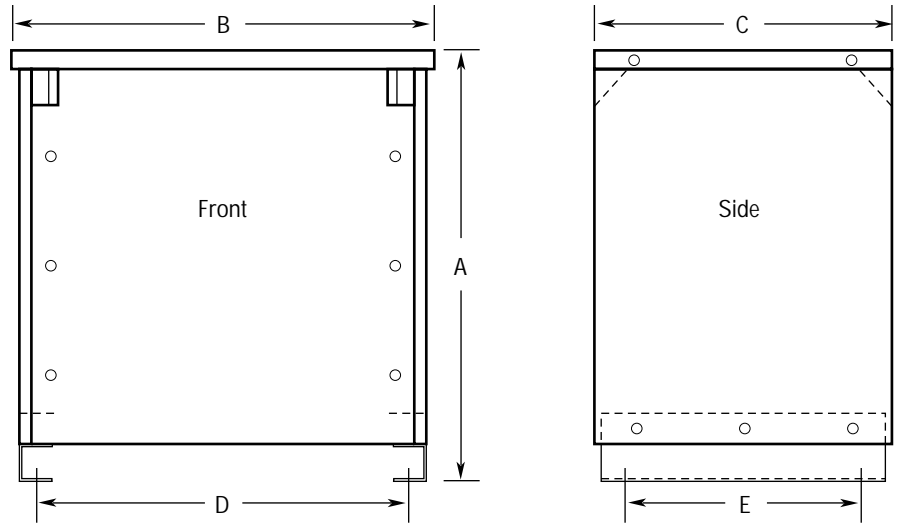

Catalog Number	kVA	A	B	C	D	E	Weight
1391-TA2	All	17.00 (432)	19.00 (483)	14.50 (368)	16.50 (419)	12.00 (305)	35.5 (16.1)

Figure A.4
External Shunt Resistor and Fuse Dimensions
Dimensions are in inches and (millimeters)

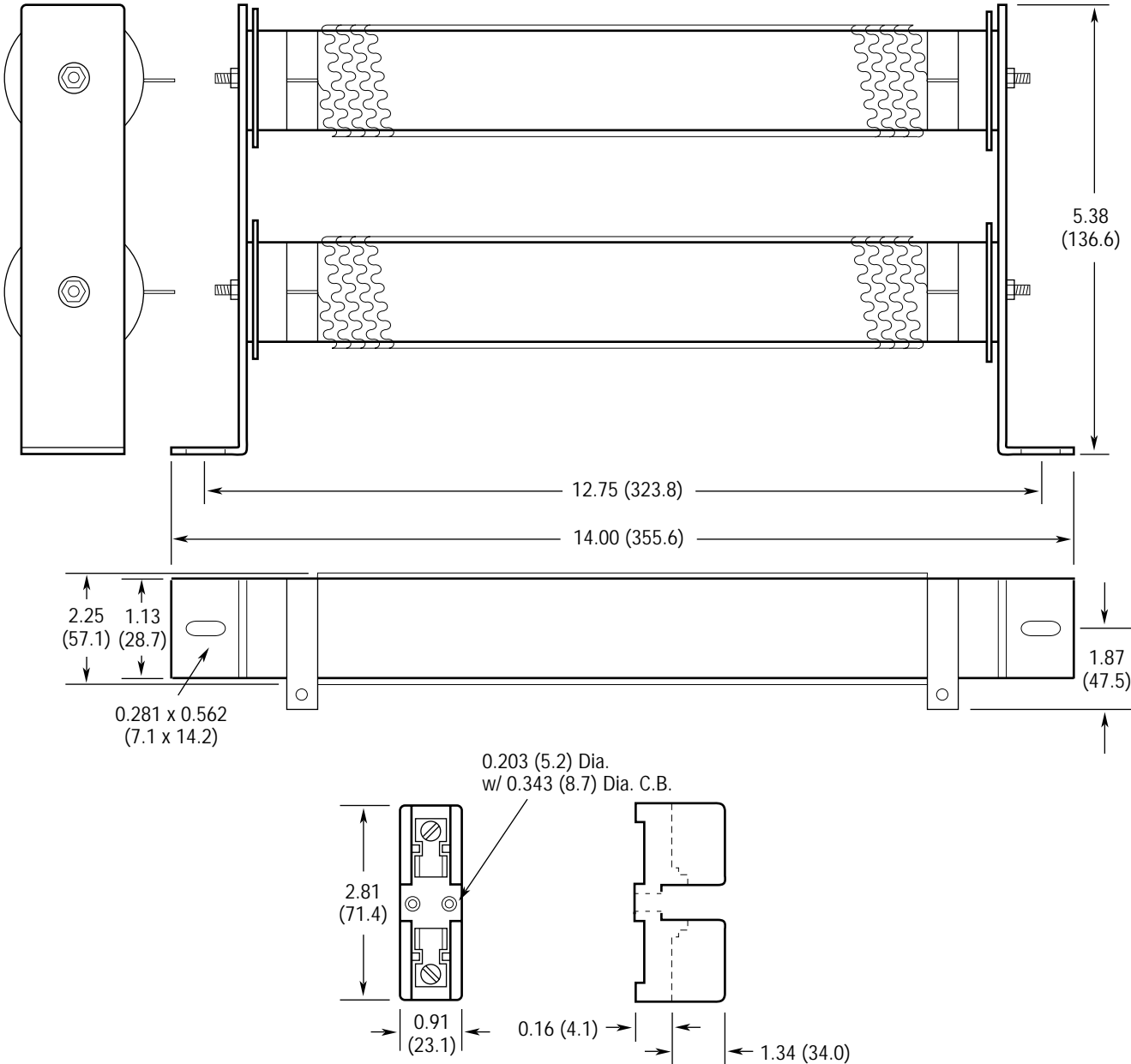

Interconnect Drawings

Objectives

Appendix B provides typical interconnection diagrams that illustrate the wiring between the 1391B-ES and various other Allen-Bradley position control products. Due to the numerous electrical circuit designs possible, these diagrams are provided for reference only.

The diagrams provided include:

- 1391B-ES interconnect drawing showing the inputs, outputs and recommended control circuitry.
- 1391B-ES / IMC 120 Interconnect Drawing
- 1391B-ES / IMC 123 Interconnect Drawing
- 1391B-ES / 8400 Series CNC Interconnect Drawing
- 1391B-ES / 8600 Series CNC Interconnect Drawing
- 1391B-ES / Creonics MAX 4 and MAX/CONTROL Interconnect Drawing

1391B-ES Interconnect Drawing

The 1391B-ES Interconnect Drawing is presented on pages B-2 and B-3. Refer to the “Notes” listed below when using this drawing.

Notes:

1) Power Wiring unless Noted:

15A	12 AWG (3.3 mm ²) min. 75C min.
22.5A	10 AWG (5.3 mm ²) min. 75C min.
45A	8 AWG (8.4 mm ²) min. 75C min.

2) Signal Wiring: 18 AWG (0.8 mm²) min.

3) Allen-Bradley Supplied Cable:

8 AWG (8.4 mm ²) Motor	126473
12 AWG (3.3 mm ²) Motor	126474
Resolver	116190

4) Customer Supplied Resolver Cable:

Belden 9873 or equivalent, 20 AWG (0.5 mm²), 30 pf/ft (97.5 pf/m) max. capacitance between conductors.

5) Terminate shield on source end only.

6) Do not make connections to unused pins on the resolver connector.

7) F3 provided on 15 & 22.5a units only. 15A=KLM-10, 22.5A=FNQ 6 1/4 series B only.

8) S2-1 ON for 1.2V/krpm, S2-1 OFF for 2.0V/krpm

9) Current Feedback Scaling: See Chapter 5

Cable Information

Cable Wiring Information

Pin-outs and interconnect information for the various 1326 cables are provided in this section.

1326-CFUxx Commutation Cable

Wire Color	Gauge (AWG)	Connector Pin	Servo Control Connection	
			1389-AAxx Terminal #	1391-AAxx Terminal #
Black	#20	A	TB2-1	TB1-10
White	#20	B	TB2-2	TB1-9
Shield - Drain	#20	N/C	TB2-3	TB1-8
Black	#20	D	TB2-4	TB1-7
Red	#20	E	TB2-5	TB1-6
Shield - Drain	#20	N/C	TB2-6	TB1-5
Black	#20	H	TB2-7	TB1-4
Green	#20	G	TB2-8	TB1-3
Shield - Drain	#20	N/C	TB2-9	TB1-2
Braided Shield	#36	N/C	TB2-10	TB1-1 to Ground Stud

1326-CPABxx Motor Power Cable

Wire Number	Wire Color	Gauge (AWG)	Connector Pin	Servo Control Connection	
				1389-AAxx Terminal #	1391-AAxx Terminal #
1	Black	12	F	TB3-1	TB5-1
2	Black	12	I	TB3-2	TB5-2
3	Black	12	B	TB3-3	TB5-3
4	Black	16	D	Brake Power	Brake Power
5	Black	16	E	Thermal Switch	Thermal Switch
6	Black	16	C	Brake Power	Brake Power
7	Drain Wire	16	G	Power Ground	Power Ground
8	Black	16	H	Power Ground	Power Ground
9	Black	16	A	Thermal Switch	Thermal Switch
Mylar Shield	Mylar Shield	16	N/C	Ground Stud	Ground Stud

1326-CPCxx Motor Power Cable

Wire Number	Wire Color	Gauge (AWG)	Connector Pin	Servo Control Connection	
				1389-AAxx Terminal #	1391-AAxx Terminal #
1	Black	8	D	TB3-1	TB5-1
2	Black	8	E	TB3-2	TB5-2
3	Black	8	F	TB3-3	TB5-3
4	Drain Wire	12	A	Power Ground	Power Ground
5	Black	12	B	Power Ground	Power Ground
6	Black	16	G	Thermal Switch	Thermal Switch
7	Black	16	H	Brake Power	Brake Power
8	Black	16	I	Brake Power	Brake Power
9	Black	16	C	Thermal Switch	Thermal Switch
Mylar Shield	Mylar Shield	16	N/C	Ground Stud	Ground Stud

1326-CVUxx Master/Vernier Resolver Cable

Master/ Vernier	Pair	Wire Color	Gauge (AWG)	Connector Pin	Description
Master	1	White	22	A	Rotor 1
		Black	22	B	Rotor 2
	2	Red	22	D	Stator 1
Black		22	F	Stator 3	
	3	Orange	22	E	Stator 2
		Black	22	G	Stator 4
Vernier	4	Blue	22	J	Rotor 1
		Black	22	K	Rotor 2
	5	Green	22	N	Stator 2
		Black	22	R	Stator 4
	6	Violet	22	M	Stator 1
		Black	22	P	Stator 3

Pairs 1, 2 and 3 are used with single device format resolvers (i.e. 1:1, 1:2, 1:2.5 and 1:5).

1326-CEUxx Encoder Feedback Cable

Pair	Wire Color	Gauge (AWG)	Connector Pin
1	Black	22	H
	White	22	A
2	Black	22	F
	Red	22	D
3	Black	22	J
	Orange	22	C
4	Black	22	I
	Blue	22	B
5	Black	22	F
	Green	22	E

1391-CAQB A Quad B Cable

The 1391-CAQB cable allows the user to connect directly from an IMC 121, 123, 123CR or 9/240 controller to the 1391B-ES controller (with A Quad B Board installed).

The 1391-CAQB Cable also carries the controller command voltage, which is connected to TB2-1 and TB2-2.

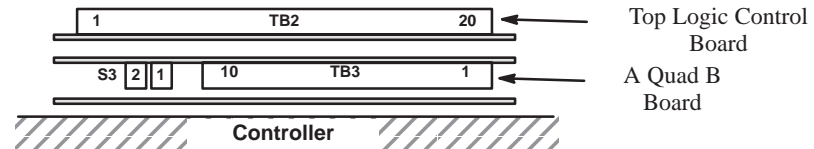

IMPORTANT: Note terminal orientation prior to wiring

<u>Cable</u>		<u>Connection</u>		
Wire Number	Wire Color	Signal	Terminal	Location
3	Black	A	TB3-1	AQB Board
12	Red	A (NOT)	TB3-2	Board
21	Shield	Common	No Connection	
4	Black	B	TB3-4	AQB Board
13	White	B (NOT)	TB3-3	Board
22	Shield	Common	No Connection	
5	Black	Z	TB3-5	AQB Board
14	Green	Z (NOT)	TB3-6	Board
23	Shield	Common	No Connection	
7	Black	+5V DC	TB3-7	AQB Board
16	Blue	Common	TB3-8	Board
24	Shield	Shield	No Connection	
9	Black	Drive	TB2-2	Logic Control Board
18	Yellow	Drive Ret.	TB2-1	Board
26	Shield	Shield	No connection	

End of Appendix

Controller Options

Zero Current Option (-A13)

The Zero Current Option allows the user to externally adjust the current limit of the controller from zero to 200% of the rated controller output.

Operation/Set-up



ATTENTION: To avoid a shock hazard, assure that all power to the controller has been removed before connecting potentiometer.

A user supplied, 10k ohm, 1/2 watt potentiometer must be connected as shown in Figure D.1 (a 10-turn potentiometer is suggested for accuracy). Attach a digital voltmeter between TP21 (+) and TP12 (-) of the controller. For zero current, adjust the 10k potentiometer until a zero (± 100 mV) reading is achieved.

Alternately, a variable 7.5V DC voltage supply can be connected to TB2-19 (+) and 20 (-). Varying the voltage at TB2-19 will modify the current limit of the controller as set by selector switch S1 (this rating will not exceed 200% of the controller current rating).

Zero volts will set the controller for zero current. 6V DC equals 200% and 7.5V DC provides 300% of the S1 setting.

Figure D.1
Option Connection

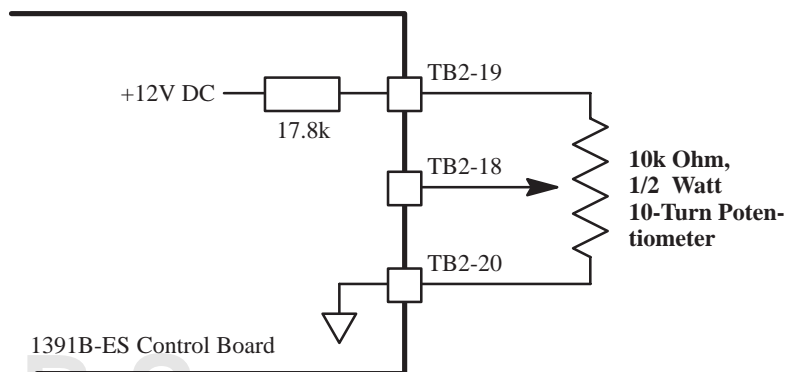

End of Appendix