



## Installing Your 1394 Drive Interface Module

(Catalog Number 1394-DIM)

### Introduction

This publication provides installation instructions for adding the 1394 Drive Interface Module to your 1394 system. Use these instructions in conjunction with the *1394 Digital, AC, Multi-Axis Motion Control System User Manual* (publication 1394-5.0).

**Note:** For instructions on using GML Commander to configure your 1394-DIM, refer to the *GML Commander Reference Manual* (publication GMLC-5.2).

The 1394-DIM acts as an interface between one 1394 GMC/GMC Turbo system module and an external axis drive(s).

On the 1394x-SJTxx-C, -C-RL, -T, and -T-RL, the 1394-DIM acts in place of one to four axis modules. On the 1394C-SJTxx-L and -L-RL the 1394-DIM acts in place of one axis module. The 1394-DIM passes a standard servo output signal from the system module to each external drive connected to the 1394-DIM. Using a 1394-DIM as part of a 1394 system lets you control external drives and motors of any size.

### Specifications

The table below lists the 1394-DIM specifications.

The:	For the 1394-DIM is:
Firmware version	3.7 or higher with 1394x-SJTxx-C-xx and -T-xx systems 3.9 or higher with 1394C-SJTxx-L-xx systems
Software	GML Commander, version 4.01 or higher
Input voltage	24V, 50 kHz provided by the 1394x-SJT-xx system module
Analog output information (Px-1,2)	
Voltage	0 to $\pm 10$ V analog
Signal isolation	1500V rms
Resolution	12 bits, 4.88 mV
Impedance	220 ohms
Offset	$\pm 80$ mV maximum, compensated to 0 through software setup
Drive OK	15V DC @ 5 mA supplied by the DIM
Drive enable output	30V DC @ 1 A
Operating temperature	0° to 50° C (32° to 122° F)
Relative humidity	5-95%
Weight	3 kg (6.6 lb)

### Certification

The certified 1394-DIM product displays the following:

- UL Listed (File E59272)
- CUL Listed
- CE marked for all applicable directives

Allen-Bradley Parts

### Dimensions

The 1394-DIM dimensions are shown below.

**Figure 1**  
1394-DIM Dimensions

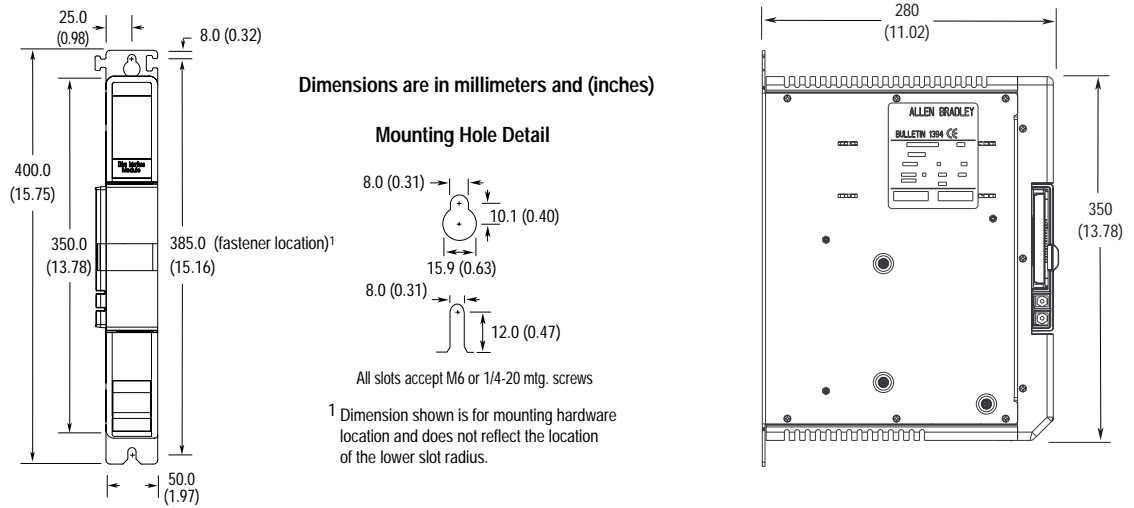

### 1394-DIM System Examples

In the figure below, the 1394-DIM is connected to a 1394 GMC Turbo with two 1394 axis modules. A 1326AB-Bxxxx motor is directly connected to each of the 1394 axis modules. Two servo amplifiers with motors are connected to the 1394-DIM. It can accept two because there are two axis modules connected to the 1394 GMC Turbo. The encoders attached to the motors have encoder feedback cables connected to the system module.

**Figure 2**  
1394-DIM Connected to a GMC or GMC Turbo

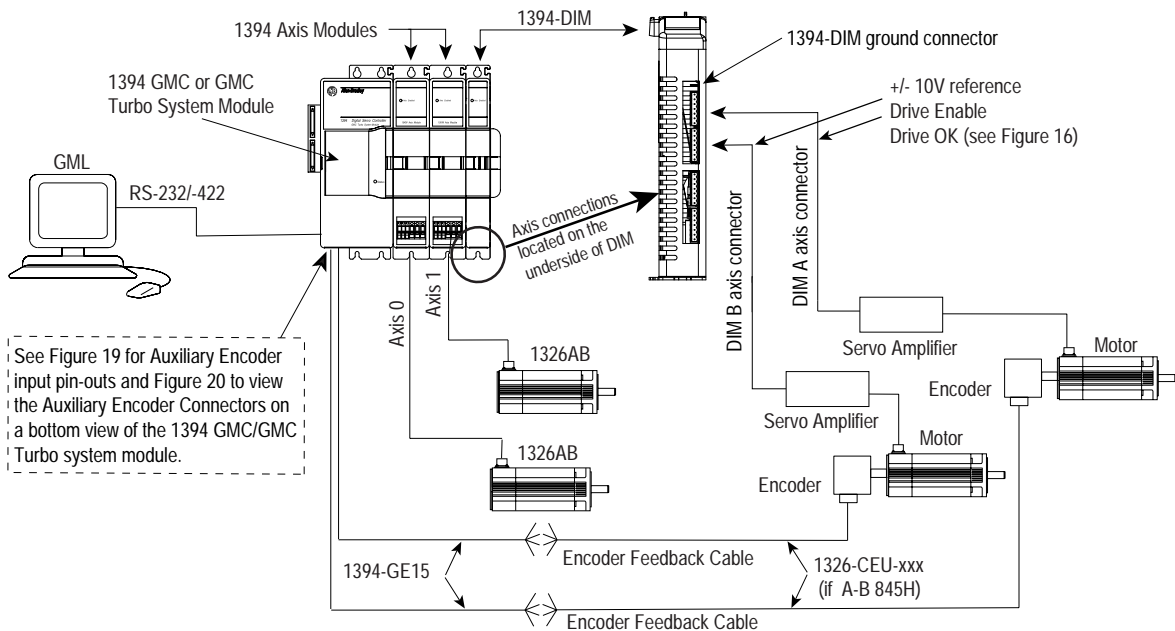

See Figure 19 for Auxiliary Encoder input pin-outs and Figure 20 to view the Auxiliary Encoder Connectors on a bottom view of the 1394 GMC/GMC Turbo system module.

In the figure below, the 1394-DIM is connected to a 1394 GMC Turbo with two 1394 axis modules and a 1398-DDM-xxx servo controller. A 1326AB-Bxxx motor is directly connected to each of the 1394 axis modules. One servo amplifier with motor is connected to the 1394-DIM.

**Figure 3**  
1394-DIM Connected to a 1398-DDM-xxx

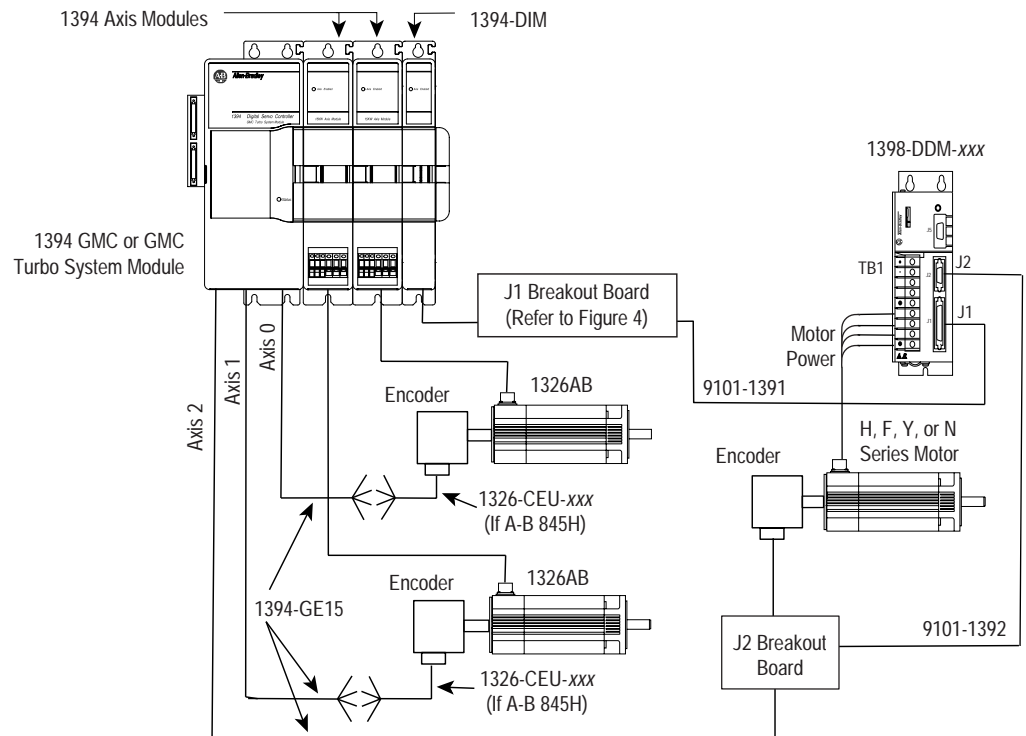
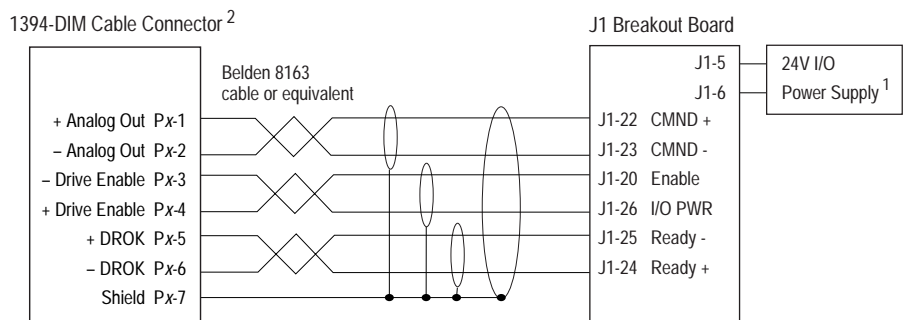

Figure 4 shows the J1 breakout board interconnect details between the 1394-DIM and the 1398-DDM-xxx. Refer to *ULTRA 200 User Manual* (publication 1398-5.0) and *ULTRA 100 User Manual* (publication 1398-5.2) for more information.

**Figure 4**  
1394-DIM to J1 Breakout Board Pinouts



<sup>1</sup> Required on ULTRA 100 only

<sup>2</sup> x = axis controlled by DIM

## Mounting Your 1394-DIM

To mount your 1394-DIM hardware:

1. Install the top mounting fastener on the system panel. The head of the fastener must be at least 0.25 inches from the panel.
2. Hang the 1394-DIM on the top mounting fastener.

**Important:** The 1394-DIM must be the last (or right-most) module in the 1394 system.

3. Engage the alignment tabs, as shown in the figure below.

**Figure 5**  
Engaging the Alignment Tab

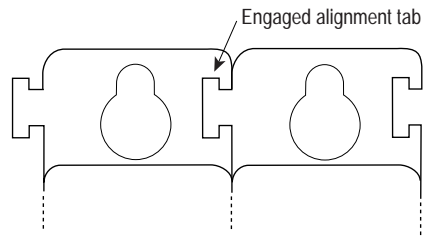

4. Slide the slide-and-lock mechanism on the 1394-DIM to the left until it locks into place, as shown in the figure below.

**Figure 6**  
Attaching the Slide-and-Lock Mechanism

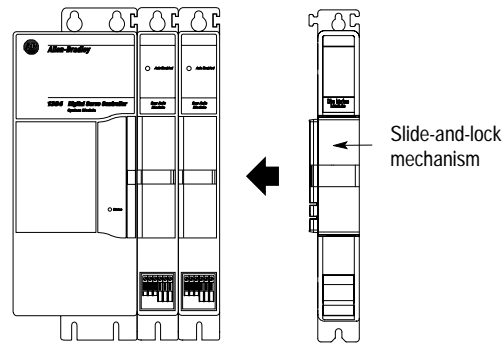

- Attach the terminator to the 1394-DIM and slide it to the left until it locks into place, as shown in the figure below.

**Figure 7**  
Attaching the Terminator

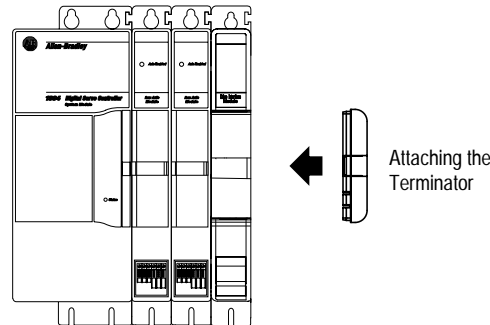

- Install the lower fastener.
- Tighten the upper and lower fasteners.

## 1394-DIM Configurations

The identity and number of the axes you can connect to a 1394-DIM depends upon the number of 1394 axis modules connected to your 1394 system in addition to the 1394-DIM.

The figure below shows the input connections located on the bottom of a typical 1394 system and a 1394-DIM.

**Figure 8**  
A 1394-DIM Connected to a GMC or GMC Turbo

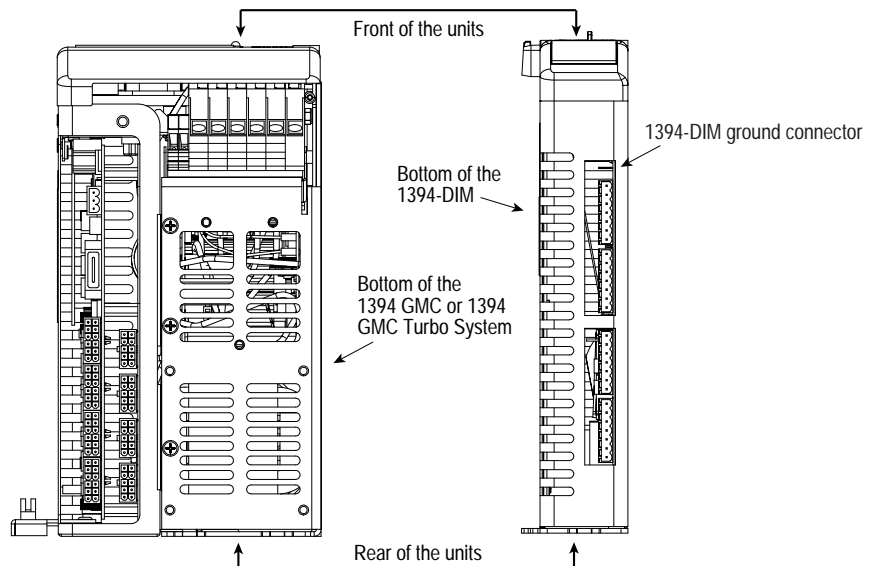

A 1394x-SJTxx-C, -C-RL, -T, and -T-RL system module can control a maximum of four physical axes. The 1394C-SJTxx-L and -L-RL can control only one axis. Each 1394 axis module added to the 1394 system reduces the number of external drives and axes the 1394-DIM can control by one.

Allen-Bradley Parts

For example, if your 1394 system includes three 1394 axis modules, the 1394-DIM can control only one external drive and axis. Refer to the table below for configuration combinations.

Number of 1394 axes:	Maximum number of DIM-controlled axes:
4	0
3	1
2	2
1	3
0	4

**Important:** You can add only one 1394-DIM to a 1394 system.

**Important:** The system requires 360/480V AC three-phase input power to run, even if the 1394-DIM is configured for four external drives.

### Configuration Examples

The following examples show a variety of ways to incorporate the 1394-DIM into a 1394 GMC/GMC Turbo System. The examples show the input connections located on the bottom of a typical 1394 system and a 1394-DIM.

The example below shows two 1394 axes and two DIM output axes.

**Figure 9**  
1394-DIM with Multiple Axis Modules

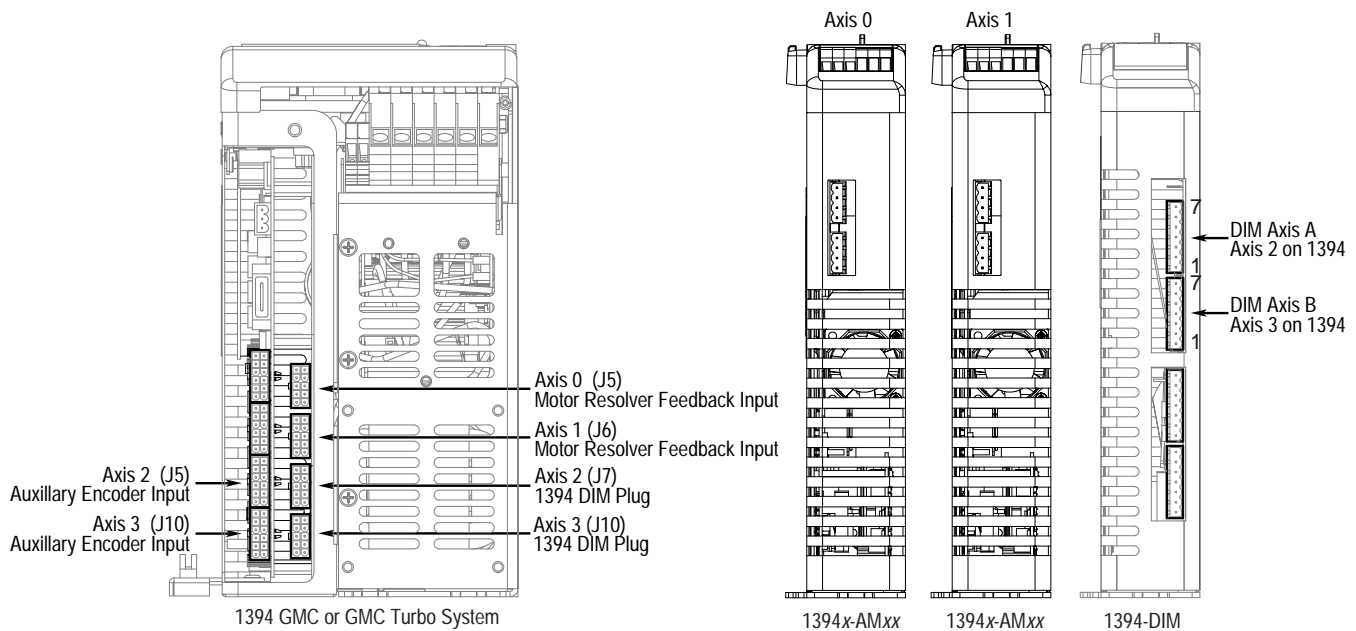

The example below shows one 1394 axis and one DIM output axis.

**Figure 10**  
1394-DIM with Single Axis Module

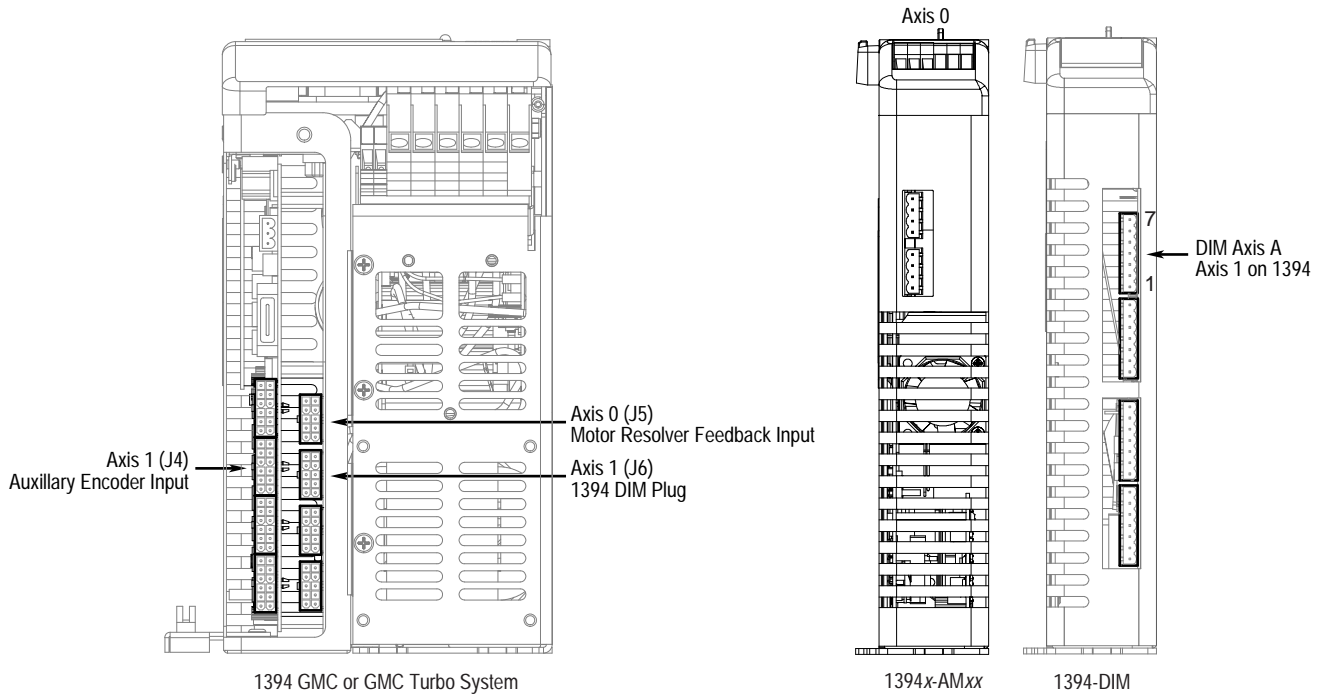

The example below shows no 1394 axes and four DIM output axes.

**Figure 11**  
1394-DIM Not Connected to Axis Module

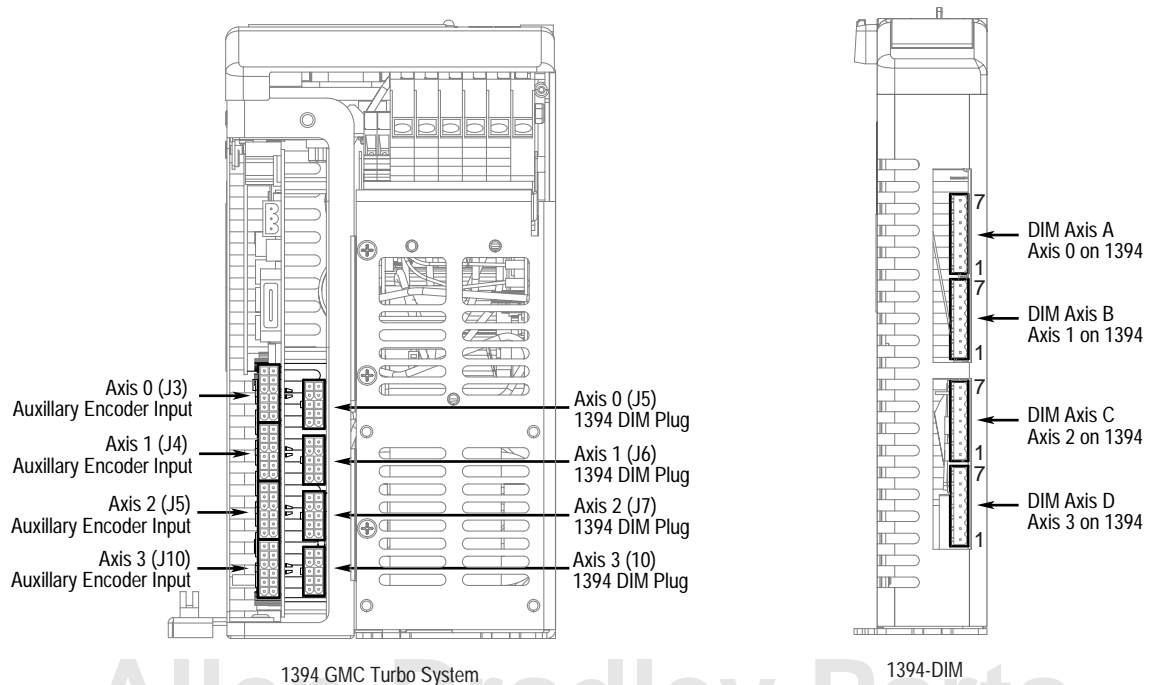

## Wiring the 1394 System Module Input Power When Not Using Axis Modules

The figure below shows how to wire the 1394 system module for input power when no axis modules are used. The transformer is rated for 480V AC secondary and 500 VA. The fuse is a Bussmann 600V AC, 10A (FRS-R-10A). The contactor is an Allen-Bradley Bulletin 100-C12x10 contactor.

**Figure 12**  
1394 System Module Wired for Input Power Without Using Axis Modules

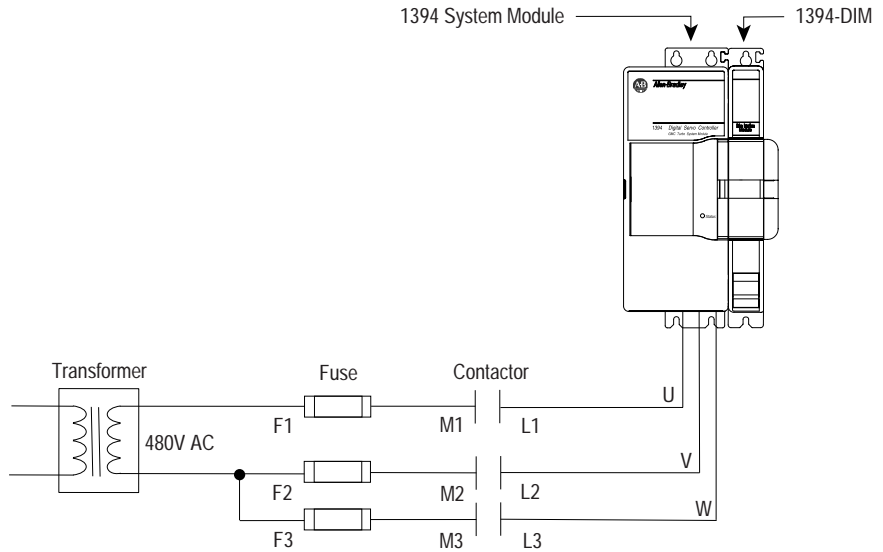

## Understanding DIM Signals

### DROK

The +/- DROK is a drive fault input from each external drive to the 1394-DIM. It consists of two wires connected to the external drive's DROK, an unpowered (dry) contact. The respective isolated + 15V DC for this input is supplied by the 1394-DIM.

**Figure 13**  
Drive OK Input

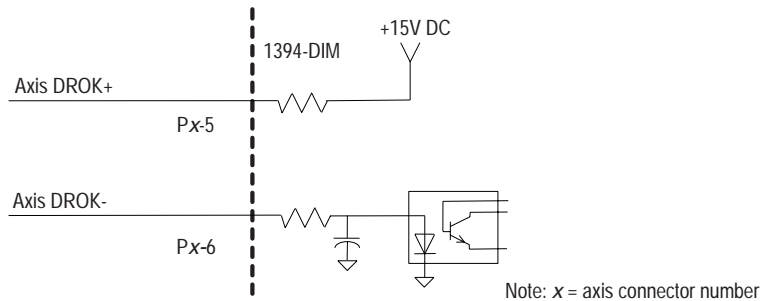



## Drive Enable Output

The +/- Axis Enable is a signal from the 1394 system module that is used to control a DPDT relay in the 1394-DIM. This enable output is a normally open, unpowered (dry) signal.

**Figure 14**  
Drive Enable Output

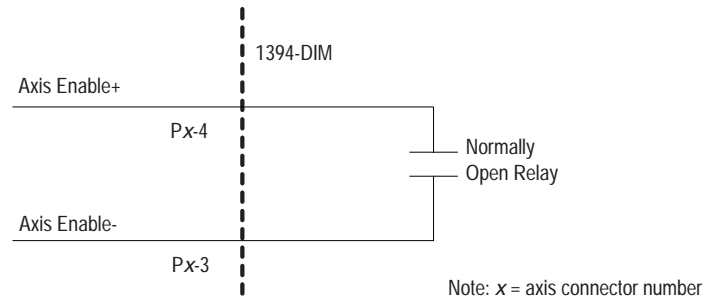

## Analog Output

The analog output is an isolated signal provided by the 1394-DIM and has a range of  $\pm 10V$ . The signal is either a torque or velocity command, depending on the configuration of the remote drive. The command is processed by the Bulletin 1394 System Module through a 12-bit Digital-Analog Converter (DAC). An output offset of  $\pm 80$  mV can be compensated to 0V through software configuration.

**Figure 15**  
Analog Output

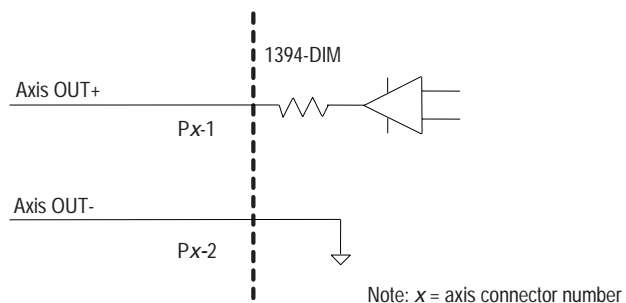

For additional DIM signal descriptions refer to the *Specifications* section in the manual.

## Wiring and Configuring an External Drive to the 1394-DIM

This section includes the following steps for wiring and configuring an external drive to the 1394-DIM:

- Connecting the remote drive to the DIM connector that provides the  $\pm 10V$  output, the drive enable output, and the drive status input.
- Connecting the position feedback encoder to the auxiliary feedback input on the 1394 GMC/GMC Turbo system module. This provides position information for closing the position and velocity loop for the drive.
- Connecting the DIM ground wire to the 1394 system module.
- Installing the resolver feedback input plug for each DIM axis to prevent resolver loss faults.



**ATTENTION:** To avoid personal injury as a result of unexpected motion or acceleration of the drive, insert the resolver plug in the correct location.

### Connecting the Remote Drive to the DIM Connector

The customer supplied DIM cable leads require terminating at the DIM cable connector. Follow one of the example configurations, as shown in the figure below.

**Figure 16**  
DIM Connector Wiring Examples

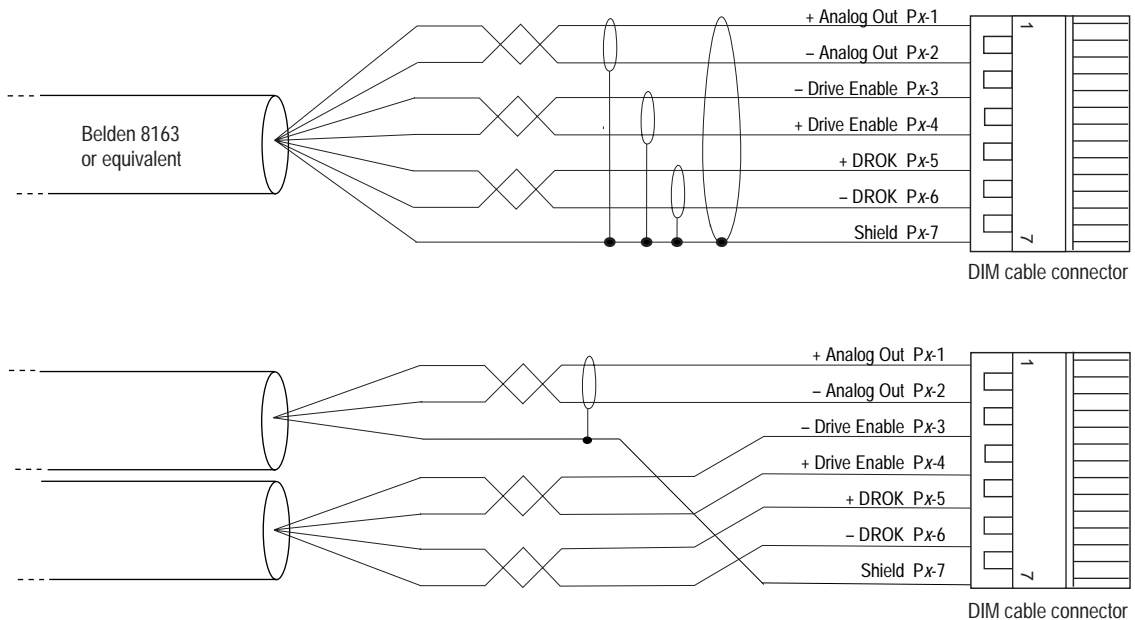

To wire the cable flying leads to the DIM cable connector:

1. Turn off the power to the system (i.e., 1394 system external drives and other control hardware).



**ATTENTION:** To avoid a shock hazard or personal injury, verify that all power has been removed before proceeding. This system may have multiple sources of power. More than one disconnect switch may be required to de-energize the system.



**ATTENTION:** To avoid hazard of electrical shock, verify that all voltage on the capacitors has been discharged before attempting to service, repair or remove this unit. This product contains stored energy devices. You should attempt the procedures in this document only if you are qualified to do so, and are familiar with solid-state control equipment and the safety procedures in publication NFPA 70E.

2. Look at the cable connector to make sure the terminal is open.  
The figure below shows a terminal open and a terminal closed.

**Figure 17**  
**Open and Closed Terminal**

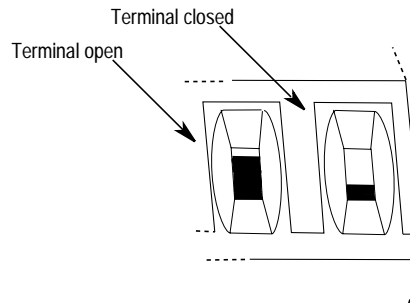

3. Using the table below, follow the correct procedure for each termination point:

If the terminal is:	Do this:
Closed	Go to step 4.
Open	Go to step 5.

4. Turn the clamping screw counter-clockwise several times with a small, flat-head screwdriver to open the termination point.

# Allen-Bradley Parts

5. Strip the wire insulation back on the cable lead.

**Important:** Use 14-20 gauge wire to ensure proper system operation.

6. Trim the cable lead to expose 7.0 mm (0.275 in.) of metal wire.
7. Insert the cable lead in the appropriate terminal.

**Figure 18**  
**Cable Connector**

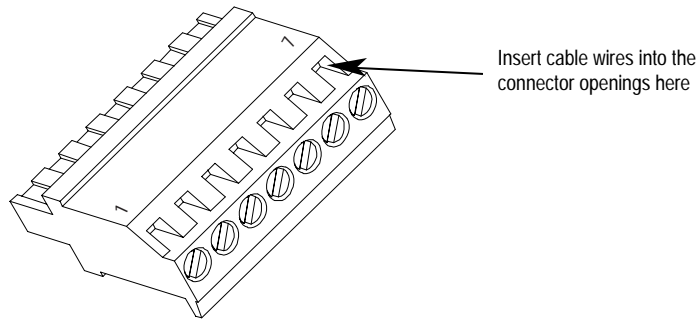

8. Use a screwdriver to tighten the clamping screw to the correct torque (0.25 N-m/2.2 lb-in.) until the cable lead cannot be pulled out of the terminal.
9. Using the table below, complete the termination connections.

<b>If the cable lead:</b>	<b>Do this:</b>
Pulls out of the terminal	Go to step 4.
Does not pull out of the terminal	<ol style="list-style-type: none"> <li>1. Move to the next terminal and go to step 2.</li> <li>2. When all seven terminals are wired, go to step 10.</li> </ol>

10. Connect each external drive to the 1394-DIM.

**Important:** Connect all DIM axes in succession (from the front of the unit to the back of the unit) starting with DIM Axis A regardless of the number of servo axis modules in the 1394 system.

### Connecting the Position Feedback Encoder to the Feedback Input

The figure below shows the pinouts and interconnect information for the auxiliary encoder input to the 1394-GMC.

**Figure 19**  
1394-GE15 Cable Connections

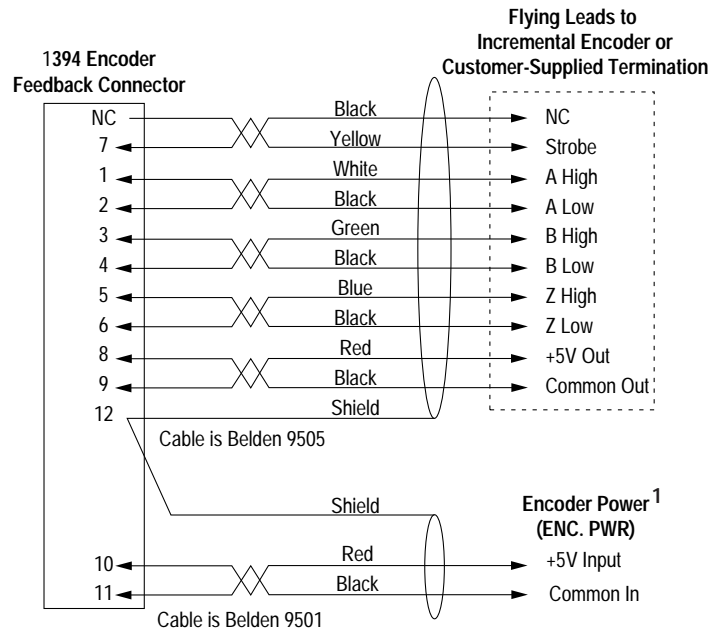

<sup>1</sup> Customer supplied 5V DC power source is required for encoder board whether encoder supply voltage is 5V or not.

To connect the encoder feedback cable to the 1394 system module:

1. Plug the 1394-GE15 cable for each DIM Axis into the correct auxiliary encoder input on the 1394 system module as shown in the table below. Refer to Figures 9, 10, and 11 for encoder input locations.

When this axis is used:	Install the Position Feedback Input plug for:			
	DIM axis A into:	DIM axis B into:	DIM axis C into:	DIM axis D into:
0 (no axis installed)	J3	J4	J5	J10
1 (axis 0 installed)	J4	J5	J10	N/A
2 (axis 0, 1 installed)	J5	J10	N/A	N/A
3 (axis 0, 1, 2 installed)	J10	N/A	N/A	N/A

Note: The other end of the 1394-GE15 cable provides flying leads and must be connected to correct signals on a quadrature encoder.

Note: The feedback inputs for axis 0, 1, 2 and 3 (on 1394x-SJTxx-C and -T systems) and for axis 0 and 1 (on 1394x-SJTxx-L systems) run from front to back (see Figure 20).

2. Connect the cable's overall braided shield to the 1394 system ground bar. For more information on grounding the 1394 system, refer to the *1394 Digital, AC, Multi-Axis Motion Control System User Manual* (publication 1394-5.0).

### Connecting the DIM Ground Wire to the 1394 System Ground

Connect one end of the ground wire to the connector on the 1394-DIM (refer to Figure 8 for location) and connect the other end to the 1394 system ground bar.

### Installing the Resolver Feedback Input Plug

For each axis controlled by the 1394-DIM, insert a 1394-DIM feedback plug into the 10-pin resolver feedback input on the 1394 system module, as shown in the table below. Refer to Figures 9, 10, and 11 for input locations and Figure 20 for the 1394 system module interconnect information.

When this axis is used:	Install the Resolver Feedback Input plug for:			
	DIM axis A into:	DIM axis B into:	DIM axis C into:	DIM axis D into:
0 (no axis installed)	J5	J6	J7	J10
1 (axis 0 installed)	J6	J7	J10	N/A
2 (axis 0,1 installed)	J7	J10	N/A	N/A
3 (axis 0,1,2 installed)	J10	N/A	N/A	N/A

**Important:** Unused DIM axis modules do not require a feedback plug to be installed.



**ATTENTION:** To avoid personal injury because of unexpected motion or acceleration of the drive, the resolver plug must be inserted in the correct location.

If you do not insert a 1394-DIM feedback plug into a 10-pin resolver feedback input for each DIM axis, a Resolver Loss Fault occurs for that axis if *Transducer Loss Detection* is selected in the Feedback page of the Configure Axis Use dialog box in GML Commander.

**Important:** 1394-DIM axes do not use the system module's thermal fault inputs. You can use these inputs for any other purpose your hardware configuration allows.

**Figure 20**  
**Bottom Front of the GMC (1394x-SJTxx-C and -L) and**  
**GMC Turbo (1394x-SJTxx-T) System Modules**

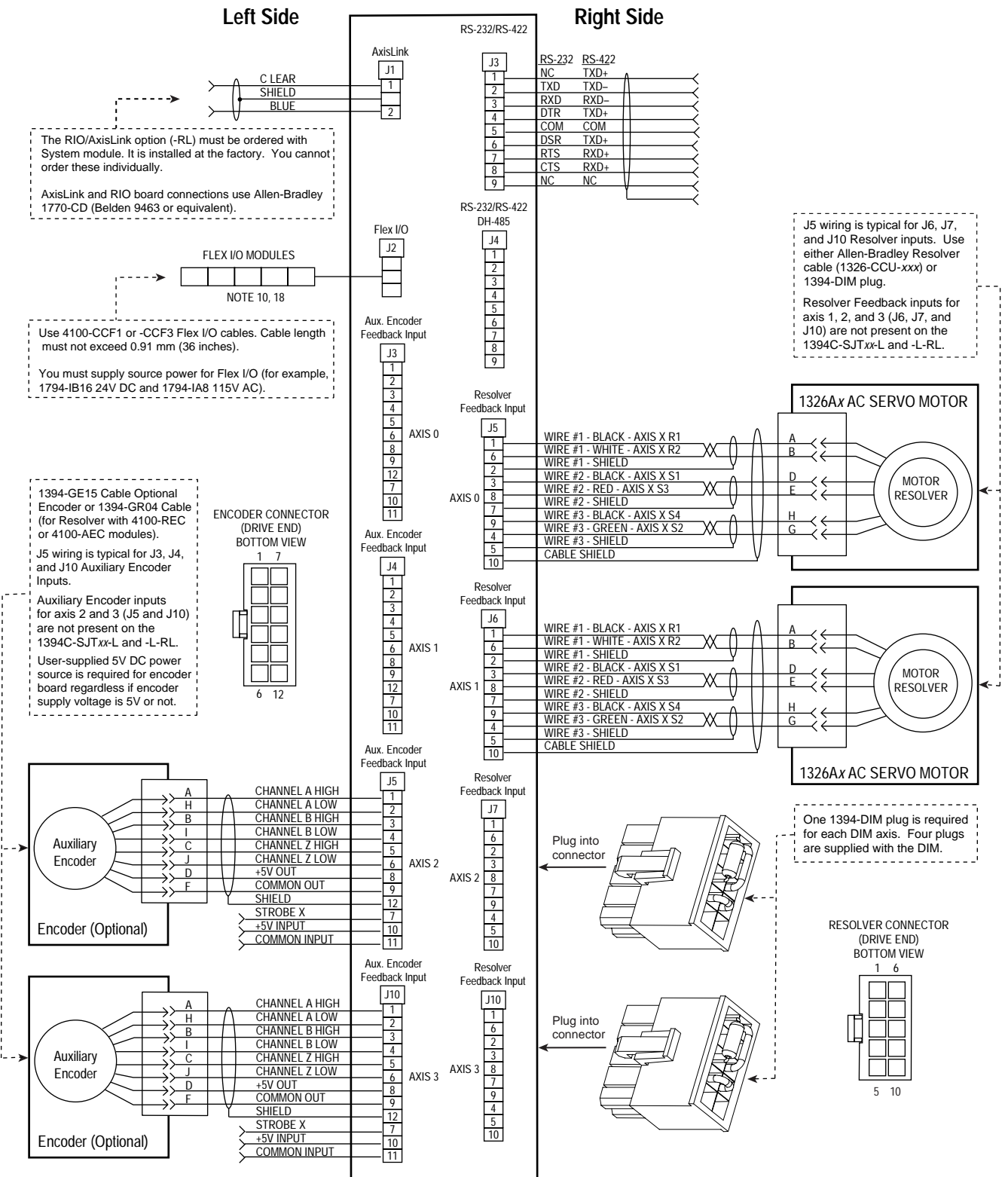

For more information refer to our web site: [www.ab.com/motion](http://www.ab.com/motion)

---

**Reach us now at [www.rockwellautomation.com](http://www.rockwellautomation.com)**

Wherever you need us, Rockwell Automation brings together leading brands in industrial automation including Allen-Bradley controls, Reliance Electric power transmission products, Dodge mechanical power transmission components, and Rockwell Software. Rockwell Automation's unique, flexible approach to helping customers achieve a competitive advantage is supported by thousands of authorized partners, distributors and system integrators around the world.

**Americas Headquarters**, 1201 South Second Street, Milwaukee, WI 53204, USA, Tel: (1) 414 382-2000, Fax: (1) 414 382-4444  
**European Headquarters SA/NV**, avenue Herrmann Debroux, 46, 1160 Brussels, Belgium, Tel: (32) 2 663 06 00, Fax: (32) 2 663 06 40  
**Asia Pacific Headquarters**, 27/F Citicorp Centre, 18 Whitfield Road, Causeway Bay, Hong Kong, Tel: (852) 2887 4788, Fax: (852) 2508 1846

Publication 1394-5.12 — December 1999  
Supersedes Publication 1394-5.0-DU3 — August 1998



195032(01)

© 1999 Rockwell International Corporation. All Rights Reserved. Printed in USA