Allen-Bradley
1397
400-600HP Inverting Fault Circuit
Breaker Kit
Cat. Nos. 1397-IFB600

What This Option Provides

This option is intended to be applied to regenerative 1397 drives with high inertia loads. High inertia loads are those where the reflected load inertia to the motor is equal to or greater than the motor's own inertia, or where the drive is frequently regenerating power to the AC line, such as in unwind and pay-off applications.

An inverting fault typically occurs as a result of loss of AC line. If this happens, the AC input transformer becomes a short circuit across the motor. Since the SCRs in the bridge no longer turn off, the motor's stored mechanical energy is regenerated into the short circuit. The inverting Fault Circuit Breaker interrupts the generator action, protecting the SCR bridge and the motor.

The Inverting Fault Circuit Breaker is a magnetic-only breaker with an adjustable instantaneous magnetic trip unit. The trip settings are adjusted by a sliding control on the front of the breaker. The standard interrupt rating is 30,000 amperes symmetrical at 480 VAC.

What This Kit Contains

Each 1397-Inverting Fault Circuit Breaker kit includes:

- (1) Inverting Fault Circuit Breaker Assembly
- (6) M6 × 12 mm Self-Tapping Screw
- (1) Wire Assembly
- (1) 1/4" Spade Terminal, Male
- (1) 7/16" Split Lockwashers
- (1) 1/2" Ring Lug, 22-16 ga.
- (1) Twisted Pair Wire Assembly
- (2) Shield, Top and Bottom

What These Instructions Contain

These instructions and any accompanying instructions contain the necessary information to install a 1397 Inverting Fault Circuit Breaker Kit on 1397 DC Drives rated 400 to 600HP @ 460 VAC only.

AB Spares

Installation



ATTENTION: Electric Shock can cause injury or death. Remove all power before working on this product.

The drive is at line voltage when connected to incoming AC power. Before proceeding with any installation or troubleshooting activity, disconnect, lockout and tag all incoming power to the drive. Verify with a voltmeter that no voltage exists at input terminals 181 (L1), 182 (L2) and 183 (L3).

You are responsible for conforming with all applicable local, national and international codes when installing this kit.

Mounting

1 Remove and lockout all incoming power to the drive. Verify that the Inverting Fault Circuit Breaker switch is in the OFF position.

2 Choose an appropriate location for mounting the Inverting Fault Circuit Breaker. Note that wire assemblies shipped with the kit are 152.4 cm (60 inches) in length.

3 Drill the holes (5.4 mm diameter) for the six (6) M6 self-tapping screws provided to mount the Inverting Fault Circuit Breaker assembly. Use the mounting hole pattern shown in Figure 1.

4 Mount the Inverting Fault Circuit Breaker as follows:

- a. Drive the top two (2) M6 self tapping screws half way into the holes drilled in Step 3.
 - b. Lift the Inverting Fault Circuit Breaker assembly up into position and mount it so the keyholes fit over the screw heads installed in step a. Slide the assembly down so the screws are in the keyhole slots.
 - c. Install the four remaining M6 screws.
 - d. Tighten all screws to 5.1 Nm (45 in-lb) +/- 10%
-

Figure 1.
Inverting Fault Circuit Breaker
Mounting Hole Pattern]

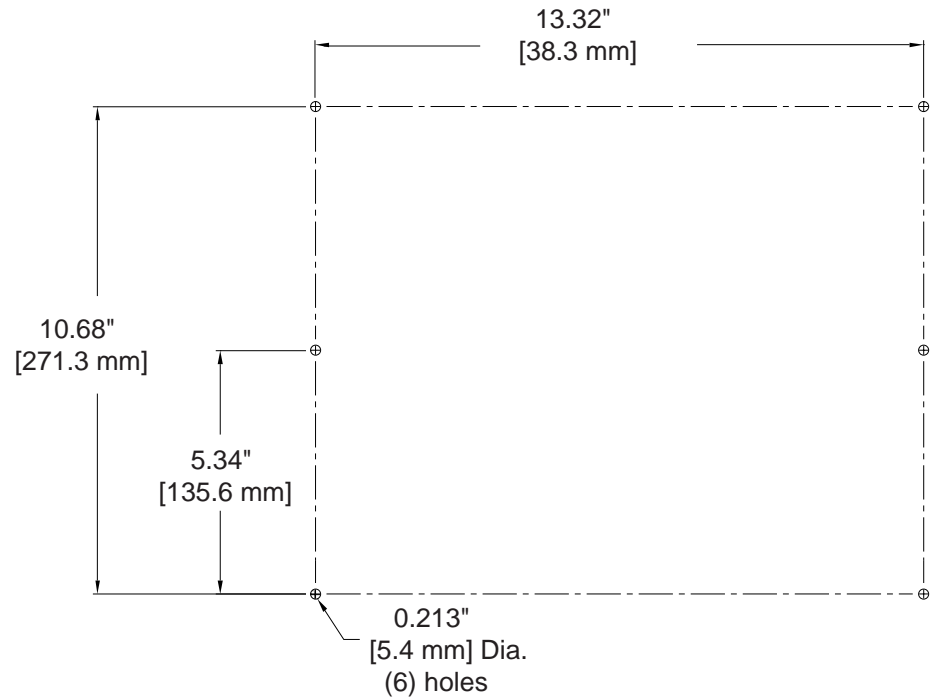

Wiring

The method used to wire the Inverting Fault Circuit Breaker depends on whether the drive is equipped with dynamic braking and/or a motor series field. Choose the appropriate wiring procedure for your application from the following procedures:

If you are using the Inverting Fault Circuit Breaker only (no dynamic braking and no motor series field):

-
- ❑ 1 Referring to Figure 2, connect the motor armature lead A2 to Inverting Fault Circuit Breaker terminal MOT. Refer to Figure 9 for the location of the breakers's MOT terminal.) Terminate the breaker side of the leads with lugs of the appropriate gauge.
-

Figure 2.
Inverting Fault Circuit Breaker Diagram
400 HP to 600 HP @ 460 VAC

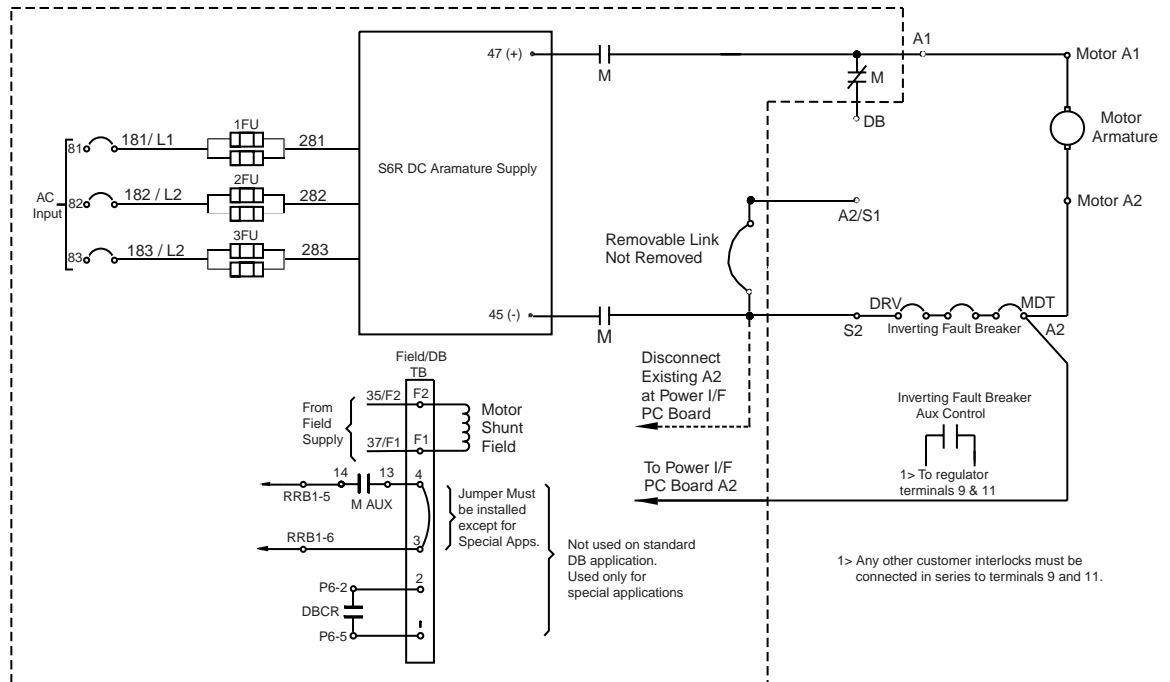

- ❑ **2** Using wire of the same gauge as the motor leads, connect Inverting Fault Circuit Breaker terminal DRV to drive output terminal S2. (Refer to Figure 9 for the location of the breaker's DRV terminal.) Terminate the breaker side of the wires with lugs of the appropriate gauge.

- ❑ **3** Connect motor armature lead A1 to drive terminal A1.

Proceed to "Wire Assembly Connections."

Wiring

If you are using the Inverting Fault Circuit Breaker with Dynamic Braking:

- ❑ 1 Refer to Figure 7. Remove the removable link (bus section connected to drive output terminal A2/S1) by removing the four nuts and bolts that hold it in place. You may need to dismount the drive in order to gain access to the removable link. If so, re-mount the drive after the link has been removed.
- ❑ 2 Refer to Figure 3. Connect motor armature lead A2 to Inverting Fault Circuit Breaker terminal MOT. (See Figure 9 for the location of the breakers MOT terminal.) Terminate the breaker side of the leads with lugs of the appropriate gauge.

Figure 3.
Inverter Fault Circuit Breaker
with Dynamic Braking

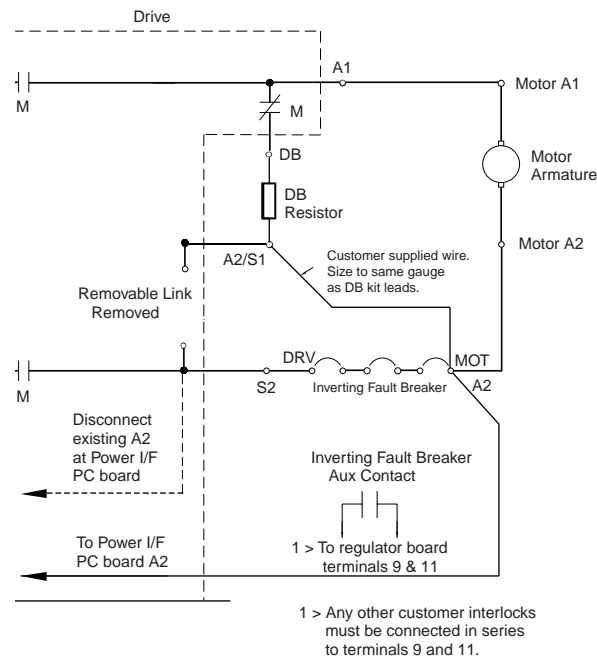

- ❑ 3 Using wire the same gauge as the motor leads, connect Inverting Fault Circuit Breaker terminal DRV to drive output terminal S2. (see figure 9 for the location of the breaker's DRV terminal.) Terminate the breaker side of the wires with lugs of the appropriate gauge.
- Using wire the same gauge as the DB kit leads, connect Inverting Fault Circuit Breaker terminal MOT to drive output terminal A2/S1.

- ❑ 4 Connect motor armature lead A1 to drive terminal A1.

Proceed to "Wire Assembly Connections."

Wiring

If you are using the Inverting Fault Circuit Breaker with a Series Field (S1 to A2):

- ❑ 1 Refer to Figure 4. Connect motor series field lead S2 to Inverting Fault Circuit Breaker terminal MOT. (See Figure 9 for location of the breaker's MOT terminal. Terminate the breaker side of the leads with lugs of the appropriate gauge.

Figure 4.
Inverting Fault Circuit Breaker
with Series Field (S1 to A2)

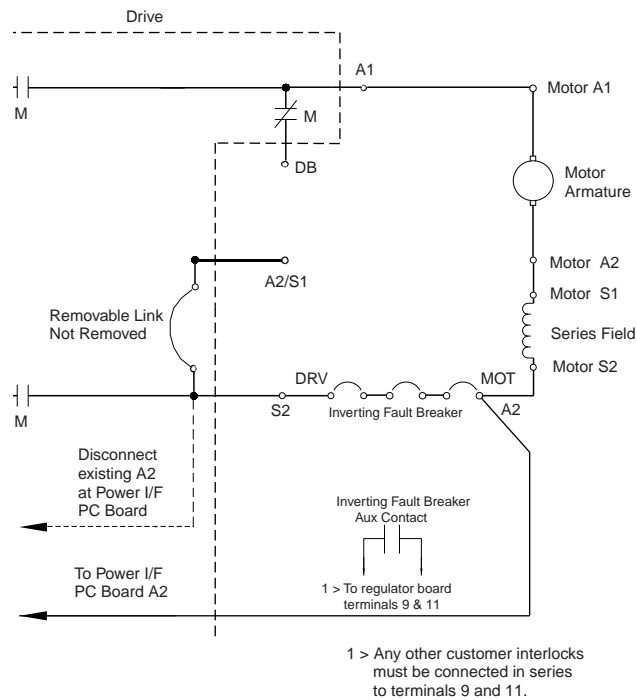

- ❑ 2 Using wire the same gauge as the motor leads, connect Inverting Fault Circuit Breaker terminal DRV to drive output terminal S2. (see Figure 9 for the location of the breaker's DRV terminal.) Terminate the breaker side of the wires with lugs of the appropriate gauge.

- ❑ 3 Connect motor armature lead A1 to drive terminal A1.

Proceed to "Wire Assembly Connections."

Wiring

If you are using the Inverting Fault Circuit Breaker with a Series Field (S1 to A2) and Dynamic Braking:

- ❑ 1 Refer to Figure 7. Remove the removable link (bus section connected to drive output terminal A2/S1) by removing the four nuts and bolts that hold it in place. You may need to dismount the drive in order to gain access to the removable link. If so, re-mount the drive after the link has been removed.
- ❑ 2 Refer to Figure 5. Connect motor series field lead S2 to Inverting Fault Circuit Breaker terminal MOT. (See Figure 9 for the location of the breaker's MOT terminal.) Terminate the breaker side of the leads with lugs of the appropriate gauge.

Figure 5.
Inverting Fault Circuit Breaker
with a Series Field and Dynamic Braking

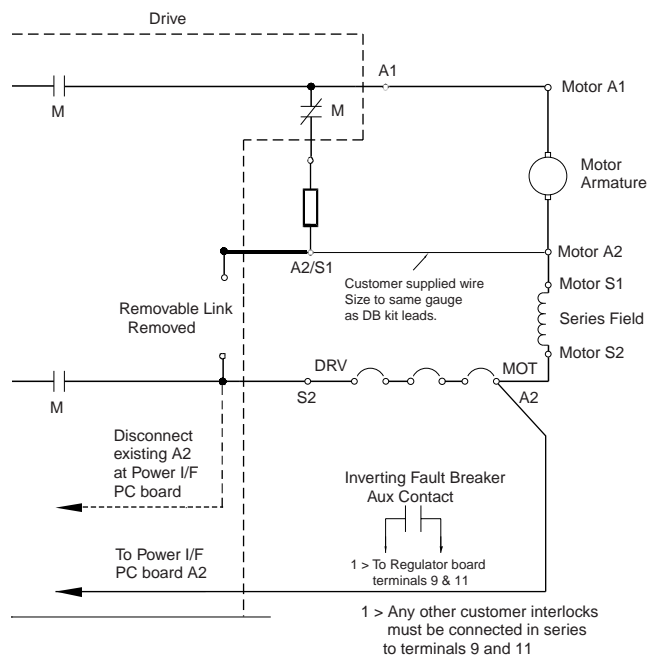

- ❑ 3 Using wire of the same gauge as the motor leads, connect Inverting Fault Circuit Breaker terminal DRV to drive output terminal S2. (See Figure 9 for the location of the breaker's DRV terminal.) Terminate the breaker side of the wires with lugs of the appropriate gauge.
- ❑ 4 Using wire the same gauge as the DB kit leads, connect motor armature lead A1 to drive terminal A1.
- ❑ 5 Connect motor armature lead A1 to drive terminal A1.

Proceed to "Wire Assembly Connections".

Wiring

If you are using the Inverting Fault Circuit Breaker with a Series Field (S1 to A2/S1) and Dynamic Braking:

- 1 Refer to Figure 7. Remove the removable link (bus section connected to drive output terminal A2/S1) by removing the four nuts and bolts that hold it in place. You may need to dismount the drive in order to gain access to the removable link. If so, re-mount the drive after the link has been removed.
-
- 2 Refer to Figure 6. Connect motor series field lead S2 to Inverting Fault Circuit Breaker terminal MOT. (See Figure 9 for the location of the breaker's MOT terminal.) Terminate the breaker side of the leads with lugs of the appropriate gauge.

Figure 6
Inverting Fault Circuit Breaker
with Series Field (S1 to A2/S1) and Dynamic Braking

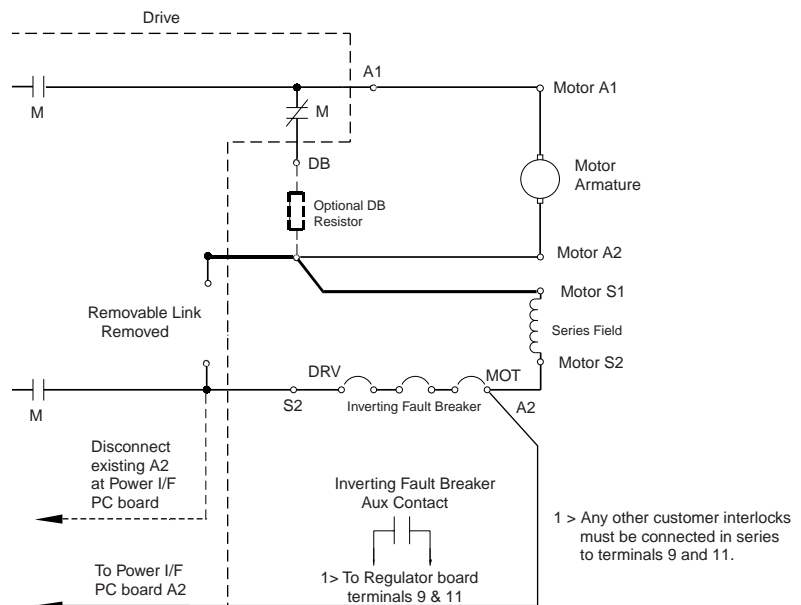

- 3 Using wire of the same gauge as the motor leads, connect Inverting Fault Circuit Breaker terminal DRV to drive output terminal S2. (See Figure 9 for the location of the breaker's DRV terminal.) Terminate the breaker side of the wires with lugs of the appropriate gauge.
-
- 4 Using wire the same gauge as the DB kit leads, connect motor armature lead A1 to drive terminal A1.
-
- 5 Using wire of the same gauge as the motor leads, connect motor armature lead A2 to drive output terminal A2/S1.
-
- 6 Connect motor armature lead A1 to drive terminal A1.

Proceed to "Wire Assembly Connections".

Figure 7.
Removable Link Location

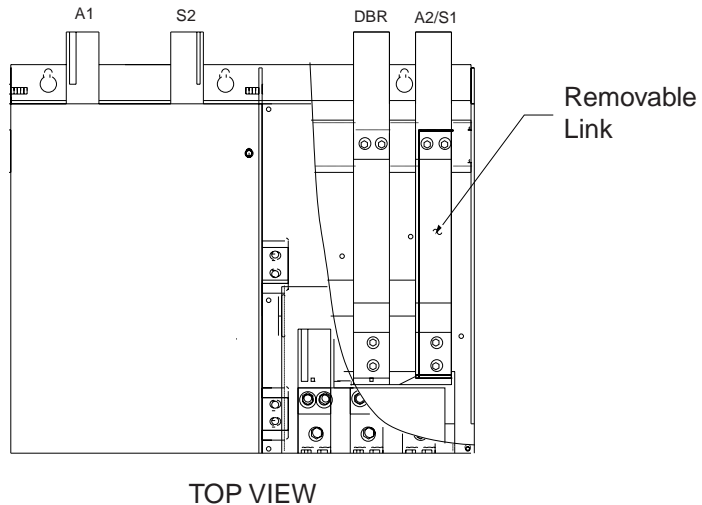

Wire Assembly Connections

-
- ❑ 1 Remove the two screws and open the drive cover (see Figure 8).
-
- ❑ 2 Locate and remove the spade connector from terminal A2 on the Power Interface board, located in the center of the drive. Cap this lead with the male spade connector supplied in this kit. (Refer to Figure 8 for the location of the Power Interface board and for the location of terminal A2.)
-
- ❑ 3 Attach the spade connector on the A2 FDBK wire lead to terminal A2 on the Power Interface board. Route this wire to Inverting Fault Circuit Breaker terminal MOT. Cut the wire to length as required and terminate the end with the ring lug supplied in the kit.
-
- ❑ 4 Connect the ring lug to terminal MOT of the Inverting Fault Circuit Breaker as shown in Figure 9.
-
- ❑ 5 Connect the spade connectors of the twisted pair harness to the male connectors on the yellow lead and the blue/yellow striped lead coming out of the Inverting Fault Circuit Breaker (see Figure 9). Route this harness to the bottom of the drive. Cut the wires to length as required, and connect them to terminals 9 and 11 on the Regulator board control terminal strip as shown in Figure 10. If any other interlocks are required for your application, they must be connected in series to the Customer Interlock Input (terminals 9 and 11) along with the circuit breaker.
-

AB Spares

Figure 8.
Power Interface Board and
Terminal A2 Locations

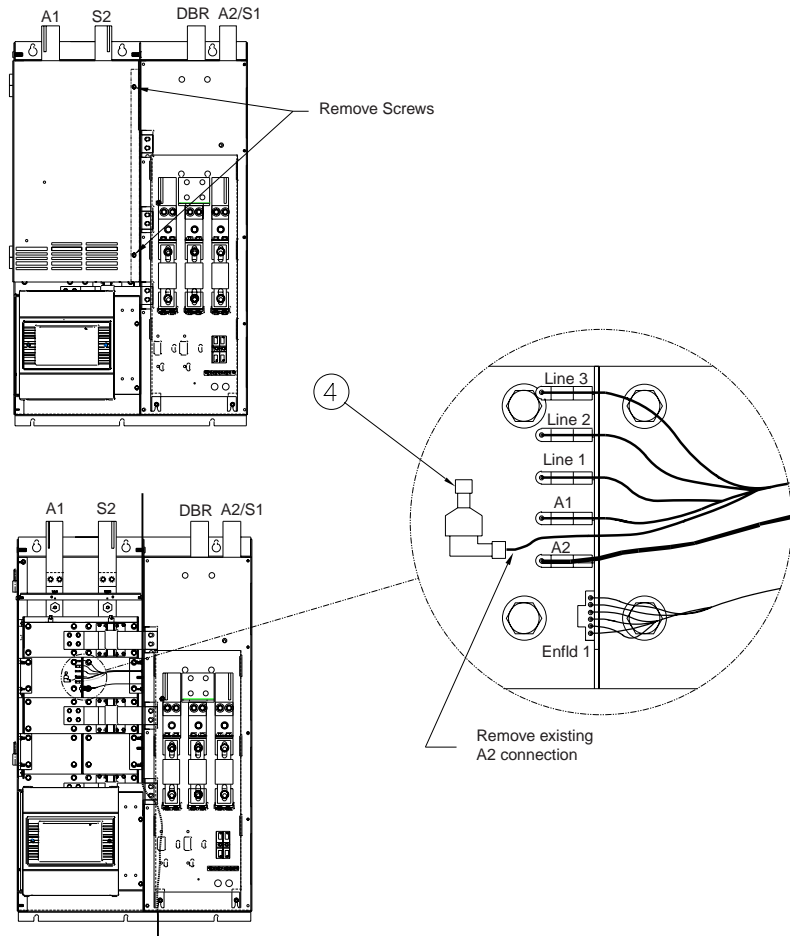

Figure 9.
Inverting Fault Circuit Breaker Terminal Locations

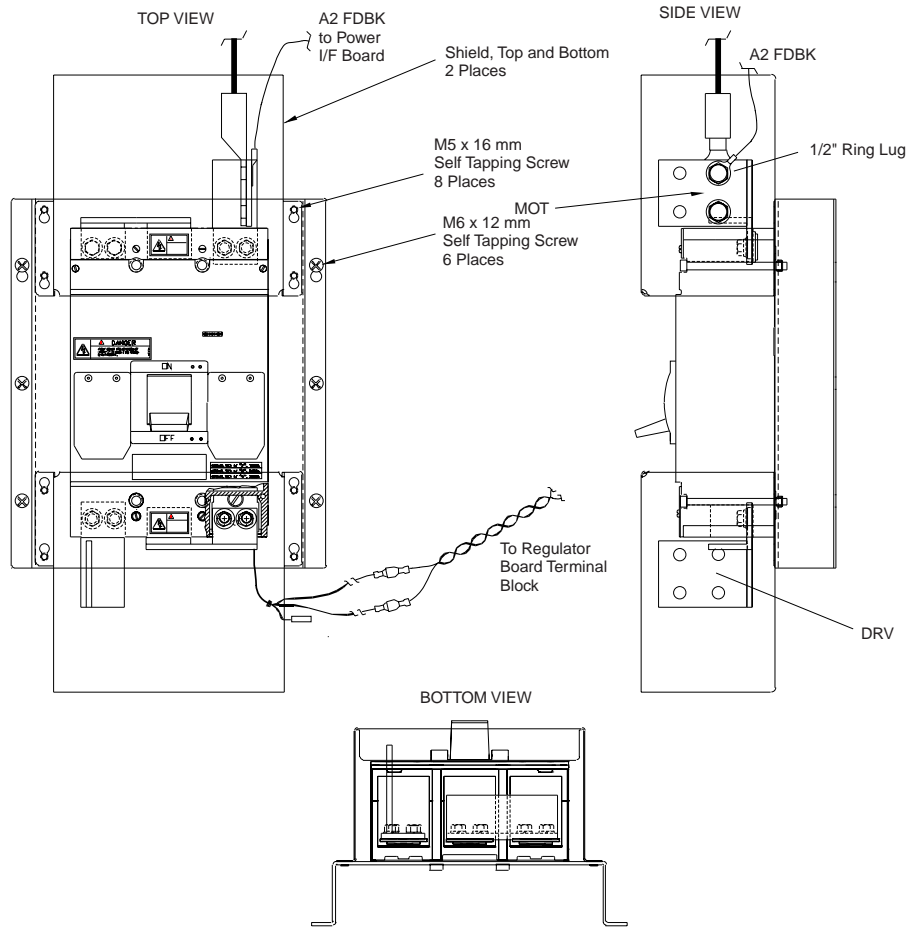
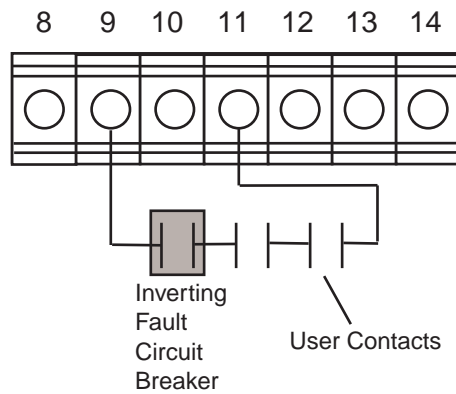

Figure 10.
Control Terminal Strip



AB Spares

Checking Circuit Breaker Settings

- 1 If necessary, adjust the circuit breaker settings using the requirements in the following table.

Drive Rated HP @ 460 VAC	Required Setting
400 HP	Set at 2 (1900 A)
500 HP	Set at 3 (2300 A)
600 HP	Set at 4 (2600 A)

- 2 Check and verify all wiring before applying power. Ensure that wires are not in contact with hot components or sharp metal edges.

- 3 Install the top and bottom shields using the following sequence:
- Refer to Figure 9 and loosen the (8) M5 x 16 mm screws in the face of the Assembly Base Plate.
 - Insert the shield keyholes onto the screws and slide each shield into place.
 - Tighten the screws to hold the shields in place. Do not overtighten.

- 4 Set the Inverting Fault Circuit Breaker to the ON position.

- 5 Remove the lockout and tag and reconnect power to the drive.

- 6 Turn on power to the drive and check for proper drive operation.

Technical Specifications

Allen Bradley Catalog Number:	1397-906FK3101
Dimensions (HxWxD):	355.6 mm x 27.58 mm x 166.37 mm
Weight:	15.14 kg (33.64 lb)
Current Rating @ 40°C:	1200A
Trip Amps	1500A to 3000A
Max AC Volts @ 50/60 Hz:	600 VAC
Max DC Volts:	600 VDC

This Page Intentionally Blank

AB Spares

This Page Intentionally Blank

Reach us now at www.rockwellautomation.com

Wherever you need us, Rockwell Automation brings together leading brands in industrial automation including Allen-Bradley controls, Reliance Electric power transmission products, Dodge mechanical power transmission components, and Rockwell Software. Rockwell Automation's unique, flexible approach to helping customers achieve a competitive advantage is supported by thousands of authorized partners, distributors and system integrators around the world.

Americas Headquarters, 1201 South Second Street, Milwaukee, WI 53204, USA, Tel: (1) 414 382-2000, Fax: (1) 414 382-4444
European Headquarters SA/NV, avenue Herrmann Debroix, 46, 1160 Brussels, Belgium, Tel: (32) 2 663 06 00, Fax: (32) 2 663 06 40
Asia Pacific Headquarters, 27/F Citicorp Centre, 18 Whitfield Road, Causeway Bay, Hong Kong, Tel: (852) 2887 4788, Fax: (852) 2508 1846



**Rockwell
Automation**