



Installation Instructions

Y-Series Brushless Servo Motor

Catalog Number Y-1002-1, Y-1002-2, Y-1003-1, Y-1003-2, Y-2006-1, Y-2006-2, Y-2012-1, Y-2012-2, and Y-3023-2

These installation instructions describe how to install the Y-Series motors. Use this document if you are responsible for designing, installing, or troubleshooting the Allen-Bradley Y-Series motor products. Read all instructions before installing this motor.

For:	See Page
Important User Information	2
Receiving and Maintenance Information	3
Motor Catalog Number Identification	3
Before You Install the Motor	4
Using Couplings and Pulleys	5
Preventing Electrical Noise	6
Building and Installing Cables	7
Installing Your Motor	8
Guidelines for Installation	9
Mounting Dimensions	10
Connector Data	13
Motor Load Force Ratings	14
Radial Load and Axial Load Force Ratings	15
Cables and Connector Kits	15

Important User Information

Solid state equipment has operational characteristics differing from those of electromechanical equipment. Safety Guidelines for the Application, Installation and Maintenance of Solid State Controls, publication [SGI-1.1](#), is available from your local Rockwell Automation sales office or online at <http://literature.rockwellautomation.com>) describes some important differences between solid state equipment and hard-wired electromechanical devices. Because of this difference, and also because of the wide variety of uses for solid state equipment, all persons responsible for applying this equipment must satisfy themselves that each intended application of this equipment is acceptable.





In no event will Rockwell Automation, Inc. be responsible or liable for indirect or consequential damages resulting from the use or application of this equipment.

The examples and diagrams in this manual are included solely for illustrative purposes. Because of the many variables and requirements associated with any particular installation, Rockwell Automation, Inc. cannot assume responsibility or liability for actual use based on the examples and diagrams.

No patent liability is assumed by Rockwell Automation, Inc. with respect to use of information, circuits, equipment, or software described in this manual.

Reproduction of the contents of this manual, in whole or in part, without written permission of Rockwell Automation, Inc., is prohibited.

Throughout this manual, when necessary, we use notes to make you aware of safety considerations.

<p>WARNING</p> 	<p>Identifies information about practices or circumstances that can cause an explosion in a hazardous environment, which may lead to personal injury or death, property damage, or economic loss.</p>
<p>IMPORTANT</p>	<p>Identifies information that is critical for successful application and understanding of the product.</p>
<p>ATTENTION</p> 	<p>Identifies information about practices or circumstances that can lead to personal injury or death, property damage, or economic loss. Attentions help you identify a hazard, avoid a hazard and recognize the consequences.</p>
<p>SHOCK HAZARD</p> 	<p>Labels may be on or inside the equipment, for example, a drive or motor, to alert people that dangerous voltage may be present.</p>
<p>BURN HAZARD</p> 	<p>Labels may be on or inside the equipment, for example, a drive or motor, to alert people that surfaces may reach dangerous temperatures.</p>

Receiving and Maintenance Information

The customer is responsible for inspecting the equipment before accepting the shipment from the freight company. Check the item(s) you receive against your purchase order.

Maintain your motor within the following environmental conditions:

- in a clean, dry location
- within the operating temperature range, 0° to 40° C (32° to 104° F)
- within the storage temperature range, -30° to 70° C (-22° to 158° F)
- within the relative humidity range, 5% to 95% non-condensing
- in an non-corrosive atmosphere

Motor Catalog Number Identification

Y - 2006 - 2 H 00 AA

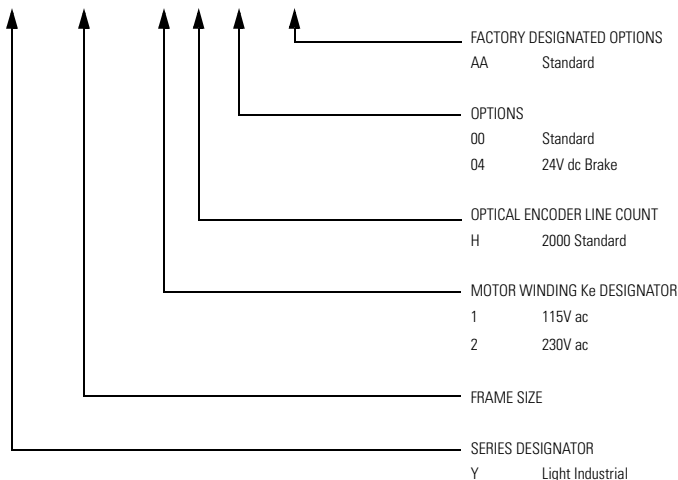

Before You Install the Motor

Before installing or storing the motor:

1. Remove the motor carefully from its shipping container.
2. Visually inspect the motor for any damage.
3. Examine the motor frame, front output shaft, and mounting pilot for any defects.
4. Notify the carrier of any shipping damage immediately.

ATTENTION



Do not open or attempt to open the motor.

Only a qualified Allen-Bradley employee can service this type of motor

Failure to observe these safety procedures could result in the equipment being damaged.

Using Couplings and Pulleys

Mechanical connections to the motor shaft, such as couplings and pulleys, require a torsionally rigid coupling or a reinforced timing belt. The high dynamic performance of servo motors can cause couplings, pulleys or belts to loosen or slip over time. A loose or slipping connection will cause system instability and may damage the motor shaft. All connections between the system and the servo motor shaft must be rigid to achieve acceptable response from the system. Periodically inspect connections to verify their rigidity.

When mounting couplings or pulleys to the motor shaft, ensure that the connections are properly aligned and that axial and radial loads are within the specifications of the motor. Refer to Motor Load Force Ratings on page 14 for guidelines on how to achieve 20,000 hours of motor bearing life.

Preventing Electrical Noise

ElectroMagnetic Interference (EMI), commonly called noise, may adversely impact motor performance by inducing stray signals. Effective techniques to counter EMI include filtering the AC power, shielding and separating signal carrying lines, and practicing good grounding techniques.

Effective AC power filtering can be achieved by using isolated AC power transformers or properly installed AC line filters.

To help avoid EMI:

1. Physically separate signal lines from motor cabling and power wiring. Do not route signal wires with motor and power wires, or over the vent openings of servo drives.
2. Ground all equipment using a single-point parallel ground system that employs ground bus bars or large straps. If necessary, use additional electrical noise reduction techniques to reduce EMI in noisy environments.

Building and Installing Cables

Knowledgeable cable routing and careful cable construction improves system ElectroMagnetic Compatibility (EMC).

To build and install cables, perform the following steps:

1. Keep wire lengths as short as physically possible.
2. Route signal cables (encoder, serial, analog) away from motor and power wiring.
3. Separate cables by 0.3 m (1 ft) minimum for every 9 m (30 ft) of parallel run.
4. Ground both ends of the encoder cable shield and twist the signal wire pairs to prevent electromagnetic interference (EMI) from other equipment.

ATTENTION

High voltage can be present on the shield of a power cable, if the shield is not grounded.

Ensure there is a connection to ground for any power cable shield.

Failure to observe these safety procedures could result in personal injury or damage to equipment.

Installing Your Motor

Y-2006, Y-2012, and Y-3023 motors include a mounting pilot for aligning the motor on a machine. Preferred fasteners are stainless steel. The installation must comply with all local regulations and use of equipment and installation practices that promote electromagnetic compatibility (EMC) and safety.

ATTENTION



Unmounted motors, disconnected mechanical couplings, and/or disconnected cables are dangerous if power is applied.

Disassembled equipment should be appropriately identified (tagged-out) and access to electrical power restricted (locked-out).

Failure to observe these safety procedures could result in personal injury

Guidelines for Installation

Observe the following for installing the motor.

1. Allow sufficient clearances in the area of the motor for it to stay within its specified operating temperature range. Refer to Receiving and Maintenance Information on page 3 for operating range. Do not enclose the motor unless forced air is blown across the motor for cooling. A fan blowing air across the motor will improve its performance. Keep other heat producing devices away from the motor.
2. Refer to Mounting Dimensions on page 10 to determine the mounting dimensions of your motor.
3. Place the motor with connectors pointing downward.
4. Properly mount and align the motor.
5. Attach all power and encoder cables after the motor is mounted and use a drip loop in the cable to keep liquids flowing away from the connectors.

ATTENTION

Outer surfaces of motor can reach high temperatures, 100° C (212° F) during motor operation.

Take precautions to prevent accidental contact with hot surfaces. Consider motor surface temperature when selecting motor mating connections and cables.

Failure to observe these safety procedures could result in personal injury or damage to equipment.

Mounting Dimensions

The dimension symbols and actual dimensions of the different models in the Y-Series are referenced in a table on the next page.

Figure 1
Reference for Mounting Dimensions

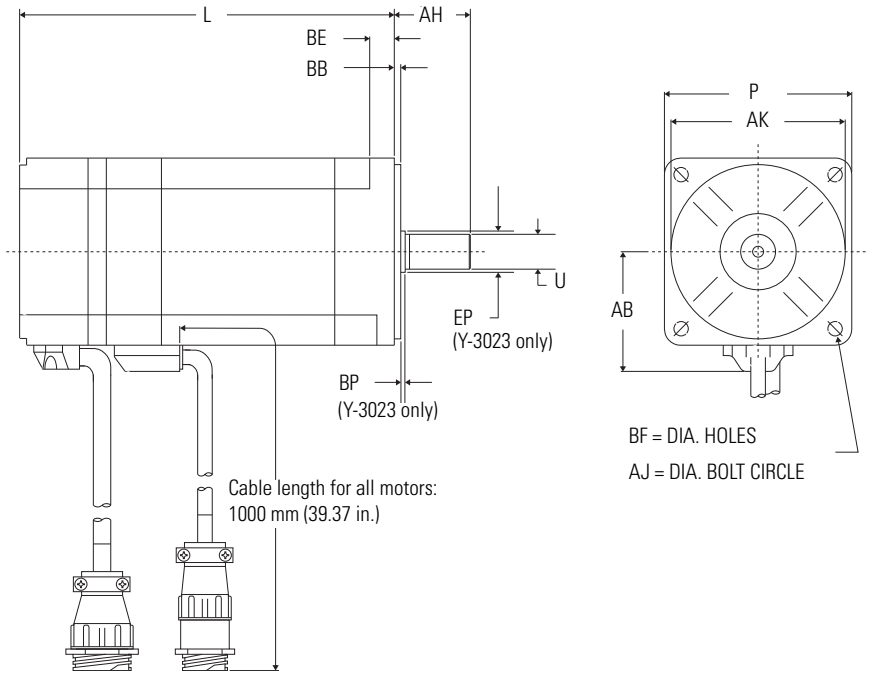

Dimension ¹ (Refer to drawing)		Motor				
		Y-1002	Y-1003	Y-2006	Y-2012	Y-3023
AB	mm	30	30	41	41	52
	(in.)	(1.2)	(1.2)	(1.6)	(1.6)	(2.0)
AH	mm	25	25	30	30	40
	(in.)	(1.0)	(1.0)	(1.2)	(1.2)	(1.6)
AJ	mm	46	46	70	70	90
	(in.)	(1.8)	(1.8)	(2.8)	(2.8)	(3.5)
AK	mm	30	30	50	50	70
	(in.)	(1.2)	(1.2)	(2.0)	(2.0)	(2.8)
BB	mm	2.5	2.5	3.0	3.0	3.0
	(in.)	(0.10)	(0.10)	(0.12)	(0.12)	(0.12)
BE	mm	5	5	6	6	8
	(in.)	(0.2)	(0.2)	(0.24)	(0.24)	(0.3)
BF	mm	4.5	4.5	5.5	5.5	6.6
	(in.)	(0.18)	(0.18)	(0.22)	(0.22)	(0.26)
BP (3023 only)	mm	—	—	—	—	2
	(in.)	—	—	—	—	(0.8)
EP (3023 only)	mm	—	—	—	—	19.5
	(in.)	—	—	—	—	(0.77)
L	mm	70	88	95.5	123.5	140
	(in.)	(2.8)	(3.5)	(3.8)	(4.9)	(5.5)
L with Brake	mm	108.5	126.5	133.5	161.5	180.5
	(in.)	(4.27)	(4.98)	(5.26)	(6.36)	(7.11)
P	mm	40	40	60	60	80
	(in.)	(1.6)	(1.6)	(2.4)	(2.4)	(3.1)
U	mm	8	8	14	14	16
	(in.)	(0.3)	(0.3)	(0.5)	(0.5)	(0.6)

Dimension ¹ (Refer to drawing)		Motor					
		Y-1002	Y-1003	Y-2006	Y-2012	Y-3023	
Shaft End Hole Thread	mm	—	—	M5 x 0.8	M5 x 0.8	M5 x 0.8	
	(in.)	—	—	(0.5)	(0.5)	(0.5)	
Shaft End Hole Thread Depth	mm	—	—	12	12	12	
	(in.)	—	—	(0.5)	(0.5)	(0.5)	
Tolerances	AH	mm	±0.8	±0.8	±0.8	±0.8	±0.8
		(in.)	(±0.315)	(±0.315)	(±0.315)	(±0.315)	(±0.315)
	AK	mm	-0.021	-0.021	-0.025	-0.025	-0.030
		(in.)	(-0.0008)	(-0.0008)	(-0.0009)	(-0.0009)	(-0.0011)
	L	mm	±1.0	±1.0	±1.0	±1.0	±1.0
		(in.)	(±0.4)	(±0.4)	(±0.4)	(±0.4)	(±0.4)
	U	mm	-0.009	-0.009	-0.011	-0.011	-0.011
		(in.)	(-0.0003)	(-0.0003)	(-0.0004)	(-0.0004)	(-0.0004)
	Cable	±100 mm (±4.0 in.)					

¹ Y-Series motors are designed to metric dimensions. Inch measurements are mathematical conversions.

Connector Data

The tables below list the signal descriptions for the encoder and power connector pins.

Encoder Connector	
Pin	Signal
1 - 8, 25-28	Open
9	A+
10	A-
11	B+
12	B-
13	I+
14	I-
15	HALL A+
16	HALL A-
17	HALL B+
18	HALL B-
19	HALL C+
20	HALL C-
21	Open
22	+5 VDC
23	COM ¹
24	Shield ²

¹ +5V COM not connected to motor case ground.

² Cable Shield connected to motor case ground.

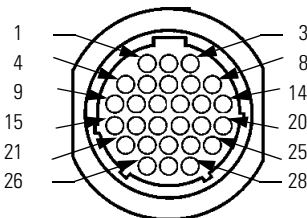

Power Connector	
Pin	Signal
1	Phase R ¹
2	Phase S ¹
3	Phase T ¹
4	Open
5	Ground
6	Open
7	Brake+ ²
8	Open
9	Brake- ²

¹ Cables and drives may label the R, S and T power phases as U, V and W respectively.

² Open on non-brake motors.

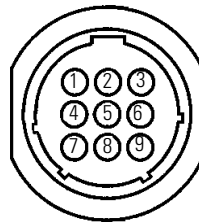

Power housing: AMP 206705-2
 Y-1002/Y-1003 contacts: AMP 66102-8
 Y-2006/Y-2012 contacts: AMP 66098-8
 Y-3023 contacts: AMP 66098-8

Encoder housing: AMP 206152-1

Encoder contacts: AMP 3-66507-0

Motor Load Force Ratings

Motors are capable of operating with sustained maximum radial or maximum axial shaft loads. The measurement points for maximum radial and axial load forces are shown in the figure below.

Figure 2
Load Forces on Shaft

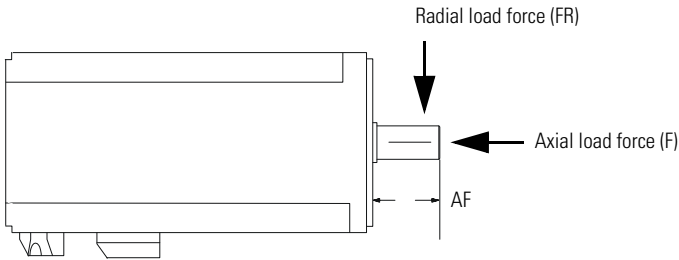

Radial load force (FR) applied to shaft at $2AF/3$.

The following table represents load factors that provide a 20,000 hour L10 bearing fatigue life for Y-Series motors. These load factors do not account for possible application-specific life reduction factors that may occur, such as bearing grease contamination from external sources.

Radial Load and Axial Load Force Ratings

Motor	Maximum Radial (FR) Load		Maximum Axial (F) Load with a Radial Load	
	kg	(lb)	kg	(lb)
Y-1002	10	(22)	3	(6.6)
Y-1003	10	(22)	3	(6.6)
Y-2006	20	(44)	8	(17.6)
Y-2012	25	(55)	10	(22.0)
Y-3023	35	(77)	20	(44.0)

Cables and Connector Kits

Factory manufactured cables are available in standard cable lengths. They can provide environmental sealing and shield termination. The following cables are for connecting the Y-Series motors.

Catalog Number	Description
9106-0066	Connector Kit (kit includes connector, pins and backshell for both the power and encoder connectors)

Rockwell Automation Support

Rockwell Automation provides technical information on the Web to assist you in using its products. At <http://support.rockwellautomation.com>, you can find technical manuals, a knowledge base of FAQs, technical and application notes, sample code and links to software service packs, and a MySupport feature that you can customize to make the best use of these tools.

For an additional level of technical phone support for installation, configuration and troubleshooting, we offer TechConnect support programs. For more information, contact your local distributor or Rockwell Automation representative, or visit <http://support.rockwellautomation.com>.

Installation Assistance

If you experience a problem within the first 24 hours of installation, please review the information that's contained in this manual. You can also contact a special Customer Support number for initial help in getting your product up and running.

United States	1.440.646.3434 Monday – Friday, 8 a.m. – 5 p.m. EST
Outside United States	Please contact your local Rockwell Automation representative for any technical support issues.

New Product Satisfaction Return

Rockwell Automation tests all of its products to ensure that they are fully operational when shipped from the manufacturing facility. However, if your product is not functioning and needs to be returned, follow these procedures.

United States	Contact your distributor. You must provide a Customer Support case number (call the phone number above to obtain one) to your distributor in order to complete the return process.
Outside United States	Please contact your local Rockwell Automation representative for the return procedure.

Allen-Bradley, Kinetix, Rockwell Automation, MP-Series, and TechConnect are trademarks of Rockwell Automation, Inc.

Trademarks not belonging to Rockwell Automation are property of their respective companies.

www.rockwellautomation.com

Power, Control and Information Solutions Headquarters

Americas: Rockwell Automation, 1201 South Second Street, Milwaukee, WI 53204-2496 USA, Tel: (1) 414.382.2000, Fax: (1) 414.382.4444

Europe/Middle East/Africa: Rockwell Automation, Vorstlaan/Boulevard du Souverain 36, 1170 Brussels, Belgium, Tel: (32) 2 663 0600, Fax: (32) 2 663 0640

Asia Pacific: Rockwell Automation, Level 14, Core F, Cyberport 3, 100 Cyberport Road, Hong Kong, Tel: (852) 2887 4788, Fax: (852) 2508 1846

Publication 1398-IN518A-EN-P — January 2001

0013-1064-001 Rev B

Supersedes Publication 1398-5.8 April 1999

Copyright © Year Rockwell Automation, Inc. All rights reserved. Printed in the U.S.A.