

CHANNEL SUPPORT • CATALOG NUMBER 1494V-H4 FOR SHORT OPERATING HANDLE (CATALOG NUMBER 1494V-H1)

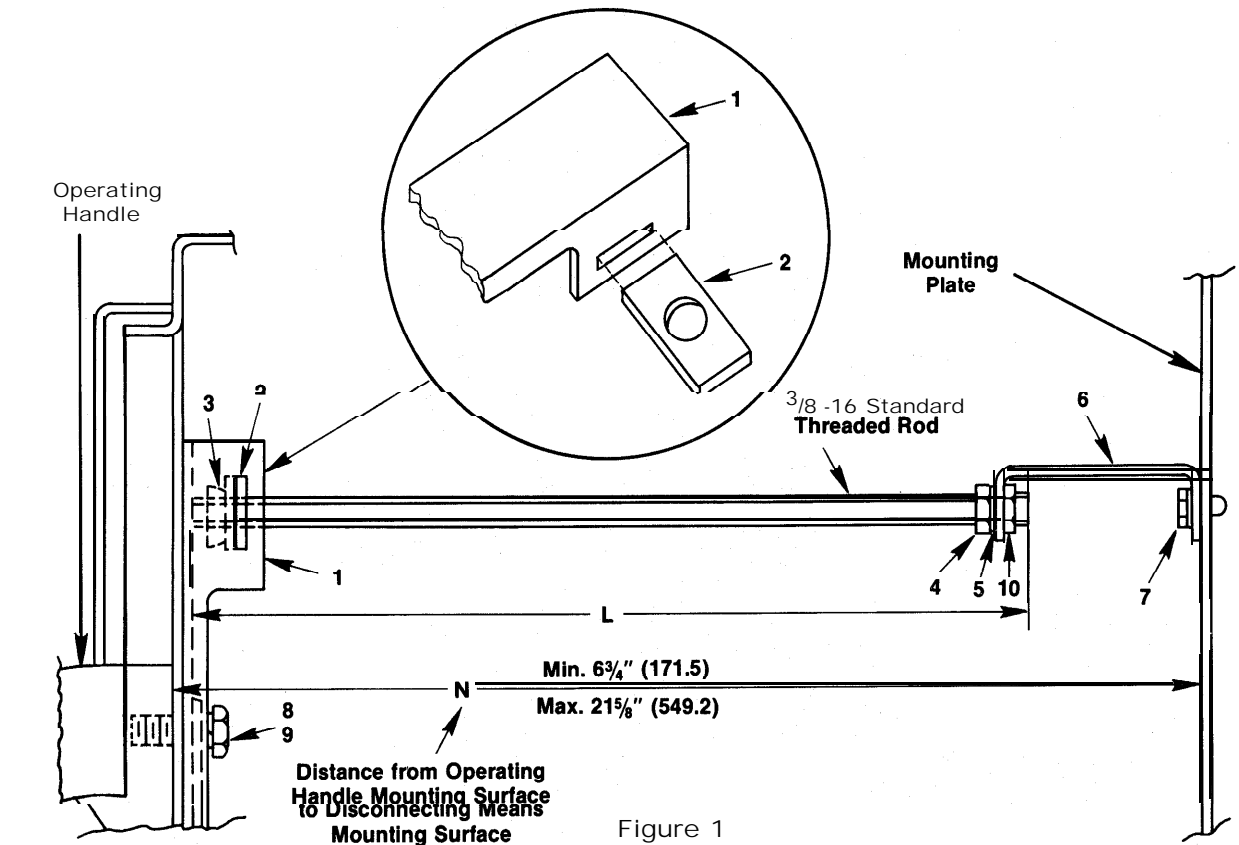

Figure 1

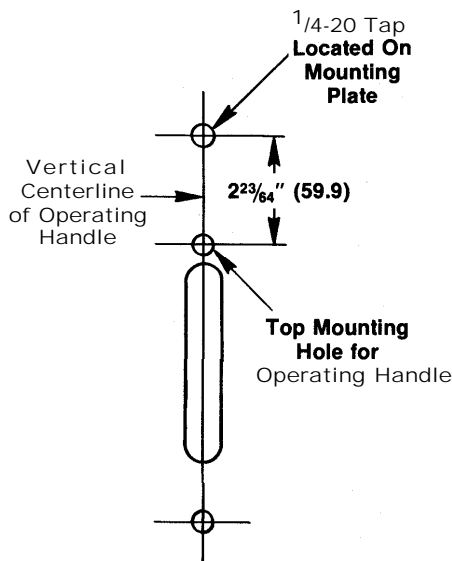

Figure 2

1. Drill and tap the $1/4-20$ hole in the mounting plate per Figure 2. Right or left-hand operation has the same drilling.
2. Cut the rod to the proper length $L = N - 2$ (50.8). See Figure 1. **Note:** The $3/8-16$ standard threaded rod is not supplied with this kit.
3. Mount the channel support bracket, Item 1, and the operating handle using the two $1/4-20 \times 3/4$ screws and lockwashers, Items 8 and 9, furnished. Do not use the two $1/4-20 \times 5/8$ screw assemblies provided with the short operating handle.
4. Thread the nut, lockwasher, and panel support bracket, Items 4, 5, and 6 on the rod approximately 2 inches.
5. Insert the support plate, Item 2, into the slots in the channel support bracket. Slide the nutsert assembly, Item 3, behind the support plate as shown in Figure 1. Thread the $3/8-16$ rod assembly through the hole in the support plate into the nutsert assembly and tighten it against the channel support bracket.
6. Turn the panel support bracket, Item 6, against the mounting plate and position as shown. Then install the $1/4-20$ screw assembly, Item 7.
7. Tighten nut, Item 10, and then nut, Item 4. Make sure the threaded rod remains tight against the channel support bracket.

NOTE: Dimensions shown in parentheses are in millimeters