



# VARIABLE DEPTH FLANGE OPERATED DISCONNECT SWITCHES

30 and 60 Ampere (Series A)

(Catalog Nos. 1494V-DS30 and 1494V-DS60)

## Instruction Sheet



### WARNING:

To avoid hazards of electrical shock, remove all power before proceeding. Auxiliary contacts commonly control separate sources of power, Be sure they and **all** sources of power are disconnected. **The procedures outlined below should only be performed by qualified personnel familiar with the operation of the equipment in which the switch is mounted.**

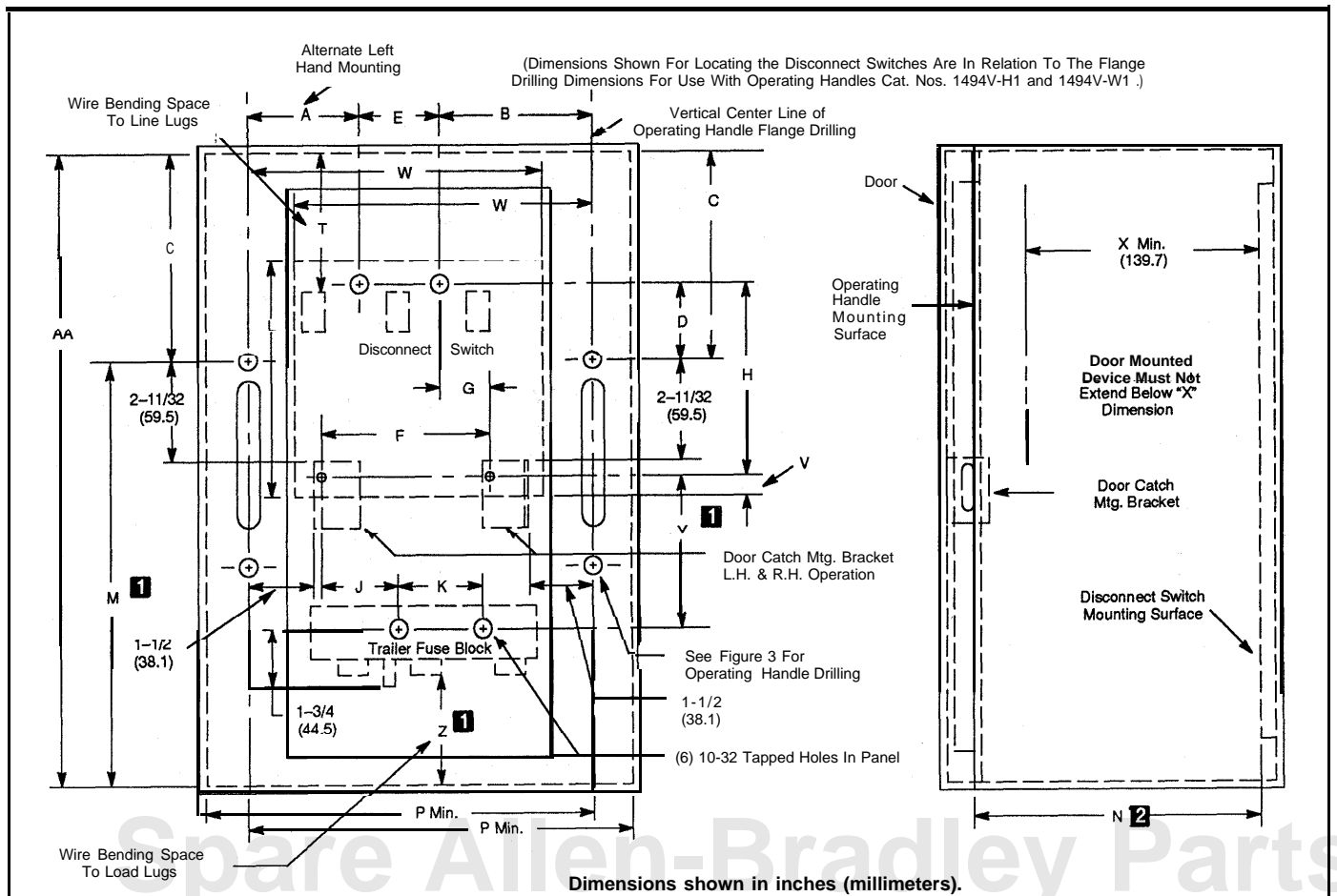

Figure 1

## Instruction Sheet

Variable Depth Flange Operated Disconnect Switches  
30 and 60 Ampere (Series A)

Figure 1 (continued)

DIMENSIONCHART- In Inches (Millimeters)											
NEMA Size (Amps)	A	B	C	D	E	F	G	H	J	K	L
30 Series A	2-37/64 (65.5)	3-29/64 (87.7)	4-1/2 (114.3)	1-27/32 (46.8)	1-31/32 (50)	3-15/16 (100)	1 (25.4)	4-21/64 (109.9)	1-13/16 (46)	1-31/32 (50)	6-19/64 (159.9)
60 Series A	2-37/64 (65.5)	3-29/64 (87.7)	4-1/2 (114.3)	1-27/32 (46.8)	1-31/32 (50)	3-15/16 (100)	1 (25.4)	4-21/64 (109.9)	1-13/16 (46)	1-31/32 (50)	6-19/64 (159.9)

DIMENSIONCHART- In Inches (Millimeters)										
NEMA Size (Amps)	N <sup>2</sup>		P MIN	R	T	U <sup>3</sup>	V	W	X MIN.	AA MIN.
	MIN.	MAX.								
30 Series A	6-3/4 (171.5)	21-5/8 (549.2)	(298.6)	1-3/4 (44.5)	2-3/4 (69.9)	3 (76.2)	1-25/64 (35.3)	7-9/16 (192.1)	5-1/2 (139.7)	17-1/2 (444.5)
60 Series A	6-3/4 (171.5)	21-5/8 (549.2)	(298.6)	1-3/4 (44.5)	2-9/16 (65.1)	3 (76.2)	1-25/64 (35.3)	7-9/16 (192.1)	5-1/2 (139.7)	17-1/2 (444.5)

□ For dimensions "M," "Y" and "Z" see Figure 4 on Page 4.

<sup>2</sup> When the large door hardware kits, Catalog Numbers 1494V-L3 or 1494V-LL3 are used, follow Publication 1494V-5.5.1 for the minimum "N" dimension.

<sup>3</sup> "U" is not illustrated on Figure 1.

## Installation

1. Determine the enclosure dimensions required for your application to verify that the enclosure is at least as large as the required minimum values and the flange design is as shown in Figure 2 on Page 3.
2. Check thickness of the flange. A thickness of 3/16" (4.8) or greater will require an alternate mounting kit (Catalog No. 1494V-H3).
3. Channel installations may require a channel support kit (Catalog No. 1494V-H4) if flexing of the channel or the backplate prevent meeting the requirements shown on Page 7, Steps 6A thru 6D.
4. Wire bending space (Dimension "T" for the line terminals and "Z" for the load terminals) is provided with the "C" and "M" dimensions shown when using Allen-Bradley lug kits. If other connectors are used or a different wire bending space is required, dimensions "T" and "Z" should be adjusted accordingly. Any change required for "T" or "Z" requires an identical change in "C" and "M," respectively.
5. Provide the flange drilling as required in Figure 3 on Page 4. The spring bracket (shown in Figure 7) provided with Catalog Numbers 1494V-H1 or 1494V-W1 operating handles can be used as a template. Determine the location of holes on the enclosure mounting plate for the disconnect switch and trailer fuse block from Figure 1 on Page 1, and the Dimension Chart on Page 2 and Figure 4 on Page 4.

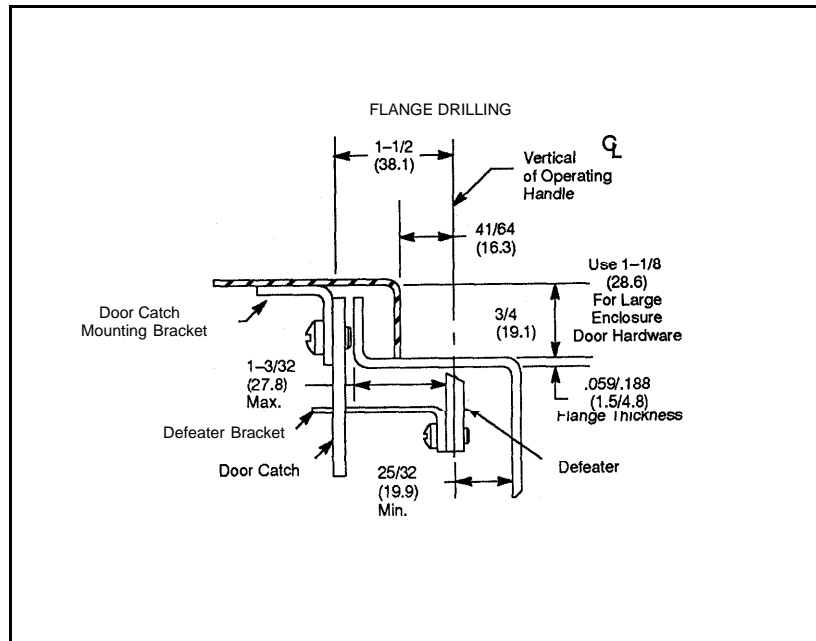

Figure 2

**NOTE:** Dimensions shown in parentheses are in millimeters.

6. Locate and assemble the door catch mounting bracket as shown in Figure 1 on Page 1 and Figure 2 above unless a door hardware kit (Catalog Numbers: 1494V-L1, 1494V-LL1, 1494V-L2, 1494V-L3 or 1494V-LL3) is used.

**NOTE:** The door catch mounting bracket is provided with projections for welding; however, holes can be drilled in the bracket using the projections for locating hole centers. After proper location, use the bracket as a template and drill corresponding holes in the enclosure door. Fasten the bracket with hardware supplied by user. If properly assembled, the hardware should not be accessible for tampering with by unauthorized personnel.

**Instruction Sheet**

Variable Depth Flange Operated Disconnect Switches  
30 and 60 Ampere (Series A)

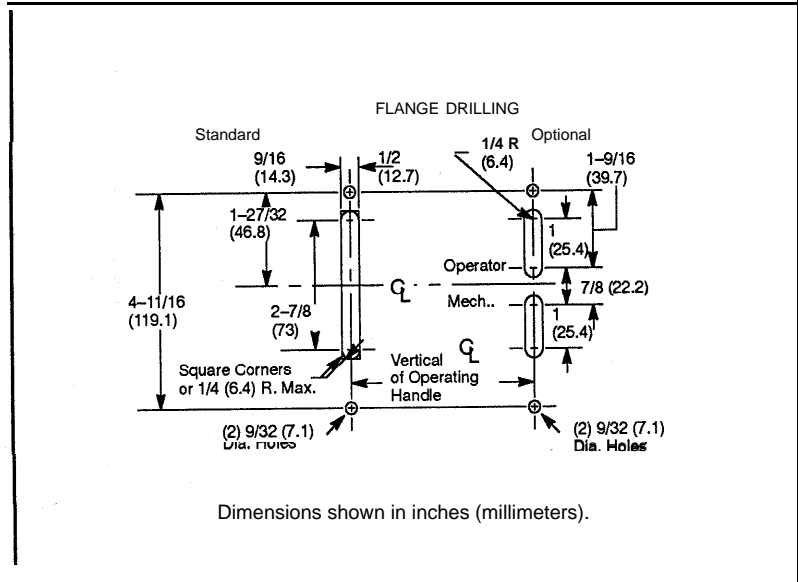

## Drive Mechanism Assembly

1. The drive mechanism (Figure 5) is assembled to the disconnect switch for right hand operation. To convert for left hand operation use the instructions on Pages 10 and 11.
2. Cut the connecting rod, Catalog Numbers 1494V-RA 1 or 1494V-RA2 (Figures 6 and 7) to the correct length using the formula  $S = N - U$ . See Dimension Chart (Figures 6 and 1) on Page 1 for the "N" AND "U" dimensions. Adding a chamfer to the threaded end will provide ease of assembly when assembled to the drive bar.

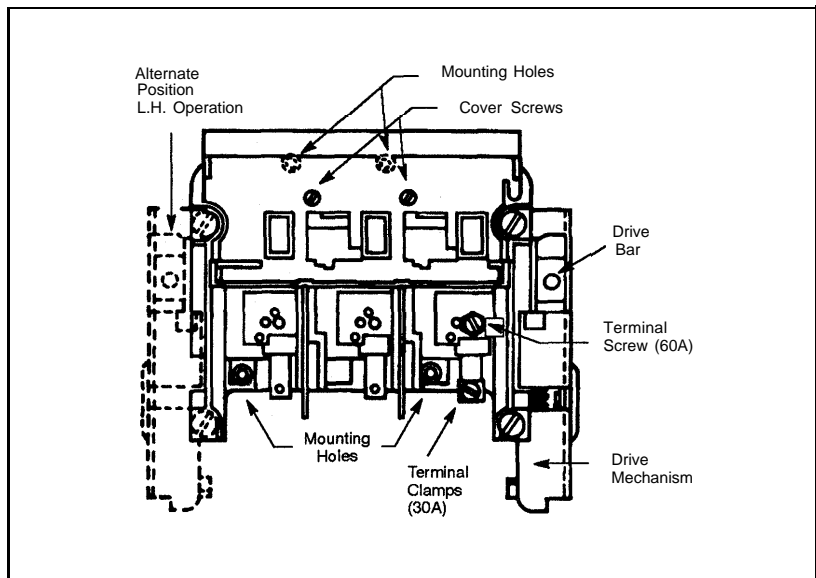

Figure 5

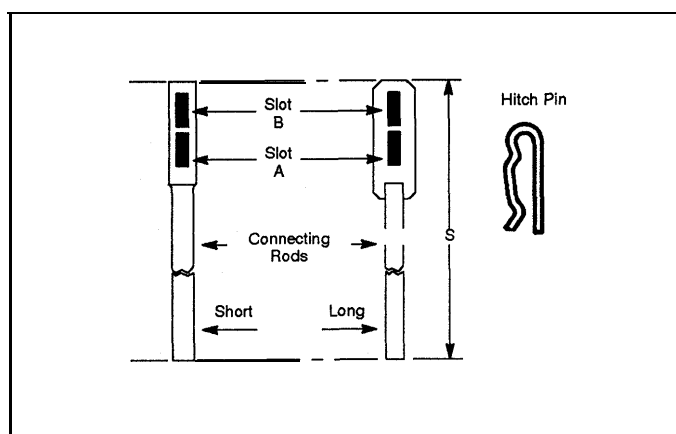

Figure 6

Rod	Catalog Number	"N"	
		Min.	Max.
Short	1494V-RA1	6-3/4" (171.5)	9-1/8" (231.8)
Long	1494V-RA2	9-1/8" (231.8)	21-5/8" (549.2)

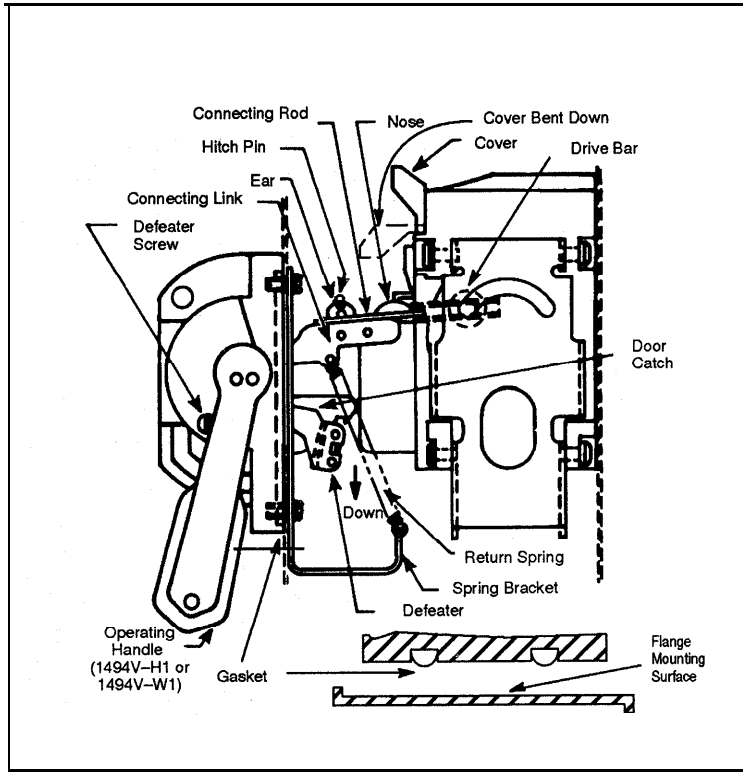

Figure 7

3. Assemble Catalog Number 1494-H1 or 1494V-W 1 operating handle, gasket and spring bracket (Figure 7) using two 1/4 - 20 x 5/8" (15.9) hex screw assemblies. Torque to 30-40 lb.-in.

**NOTE:** The gasket must be installed in the handle housing groove. See Figure 7.

4. Affix the disconnect switch with four pan head screw assemblies provided. See Figure 5 on Page 5.

**NOTE:** Bend down the line terminal guard (Figure 7) to insert and mount the two upper screws. Tighten the mounting screws to 24-32 lb.-in.

5. Install the link and connecting rod assembly
  - a. Right hand operation
    - (1) After cutting to size, turn the connecting rod twelve full turns into the drive bar (Figure 5 on Page 5 and Figure 7).
    - (2) Place the operating handle in the "OFF" position.
    - (3) Insert the nose and then the ear of the connecting link (Figure 7) through slots **A** and **B** respectively in the connecting rod (Figure 6 on Page 5). If necessary, press the defeater (Figure 7) down and lift the operating handle slightly while the connection is being made.
    - (4) Insert the hitch pin (Figure 6 on page 5) in the hole of the ear on the connecting link (Figure 7).
  - b. Left hand operation
    - (1) Turn the connecting rod nine full turns into the drive bar, Figure 5 on Page 5.
    - (2) Place the operating handle in the "ON" position.
    - (3) Insert the nose and then the ear of the connecting link (Figure 7) through slots **A** and **B** respectively in the connecting rod (Figure 6 on Page 5). If necessary, press the defeater (Figure 7) down and lift the operating handle slightly while the connection is being made.
    - (4) Return the operating handle to the "OFF" position. If the disconnect switch does not **OPEN**, return the operating handle to the "ON" position and turn the connecting rod clockwise one full turn at a time until the disconnect switch opens when the operating handle is moved to the "OFF" position.
    - (5) Insert the hitch pin (Figure 6 on Page 5) in the hole of the ear on the connecting link (Figure 7).
6. Adjustment procedure for connecting rod.
  - a. Move the operating handle to the "ON" position. If the disconnect switch does not **CLOSE** before the operating handle reaches its **FULL "ON"** position, remove the hitch pin and disengage the connecting rod from the connecting link in the "OFF" position. Turn the connecting rod **COUNTER-CLOCKWISE** one-half or one turn. Again follow step 5A (3) or B(3) to make the connection between the connecting rod and connecting link.
  - b. Repeat 6A as necessary to achieve requirements.
  - c. Move the operating handle from the "ON" to the "OFF" position. If the disconnect switch does not open before the defeater (Figure 7) starts to move down, remove the hitch pin and disengage the connecting rod from the connecting link, in the "OFF" position, and turn the connecting rod **CLOCKWISE** one-half or one turn. Reassemble the connecting rod to the connecting link following steps A(3) and B(3).
  - d. Repeat 6C as necessary.

7. Attach the handle return spring (Figure 7 on Page 6) as shown. Be sure the hitch pin (Figure 6 on Page 5) is in place.
8. Assemble the defeater bracket as shown in Figure 2 on Page 3 for right hand operation using two 6-32 X 5/16" (7.9) pan head screw assemblies. Torque to 6-8 lb.-in. Mount the defeater bracket on the opposite side of the defeater for left hand operation.
9. Fasten the door catch as shown in Figure 2 on Page 3 and Figure 7 on Page 6, to the door catch mounting bracket with two lock washers and two 10-32 X 1/4" (6.4) screws provided. Torque to 25-30 lb.-in.
10. Door catch adjustment (for enclosures without a door hardware kit). For use with Cat. No. 1494V-H1 or 1494V-W1 Operating Handle Kits.
  - a. Close the door tightly. If the operating handle cannot be moved to the "ON" position, open the door and loosen the two screws and move the door catch downward forcing it to move the defeater bracket down further.
  - b. Close the door tightly and if adjustment is correct, move the operating handle to the "ON" position. Try to open the door with the operating handle in the "ON" position. The door catch must engage the defeater bracket and prevent the door from opening fully until the defeater screw (Figure 7 on Page 6) is turned. Readjust the door catch further down if required.
  - c. Attempt to open the door while moving the operating handle from the "ON" to the "OFF" position. The door should not open before the disconnect switch is **OPEN**. Failure to meet this condition indicates that the connecting rod adjustment was not correctly made. Recheck instruction number 6C.
11. For fusible disconnect switches, remove the terminal clamps (Figure on Page 5) on the 30 amp. switch, or the terminal screws on the 60 ampere switch, and use them for connecting the power wires to the trailer fuse block terminals. Mount the trailer fuse block with the two pan head screw assemblies provided. Tighten these screws with the same torque values specified for the disconnect switch mounting screws. Mount the fuse clips as required. The tightening torque for the fuse clips is specified on the trailer fuse block kits instruction sheets. The tightening torque for the wire connections is specified on the fuse barriers installed on the disconnect switch.

**NOTE:** On factory assembled devices, fuse clips, terminal clamps and terminal screws are already installed as required.

12. Bend down the line terminal guard (Figure 7 on Page 6) to aid in wiring the line terminals. For easy access to the line lug mounting screws on the 60 ampere switch, loosen the two cover screws (Figure 5 on Page 5) and bend the cover down by way of the second hinge.

**NOTE:** The cover screws must be tightened again before operating the switch. Tightening torque must not exceed 8 lb.-in.



## Crossbar Assembly

1. With the disconnect switch in the "OPEN" position, loosen and remove the four screws and remove the drive mechanism from the right hand side of the disconnect switch. Save the four 1/4-20 pan head screw assemblies shown in Figure 8.

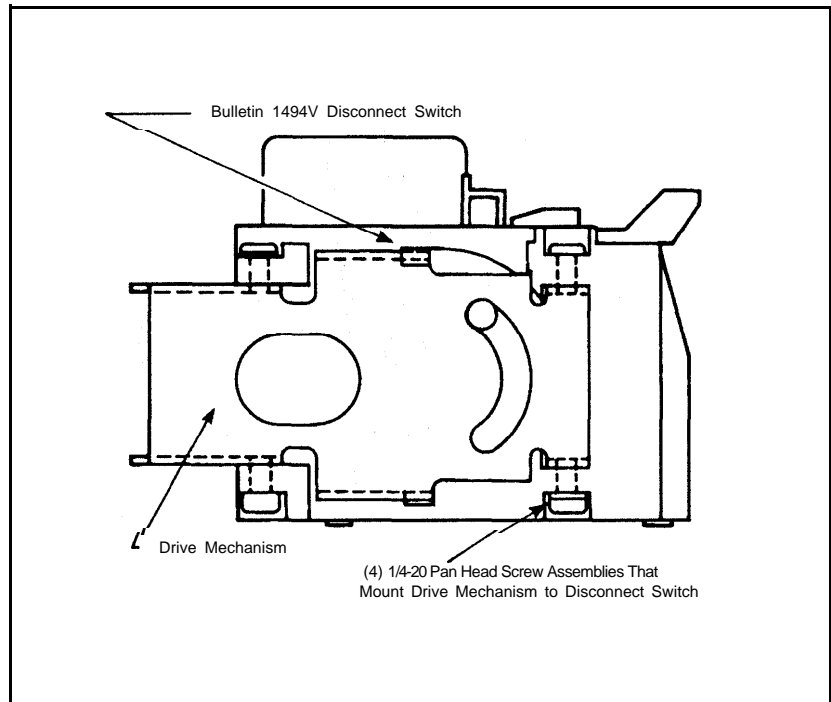

Figure 8

2. Insert the rectangular metal plate provided into the crossbar end slot on the right hand side. See Figure 9.

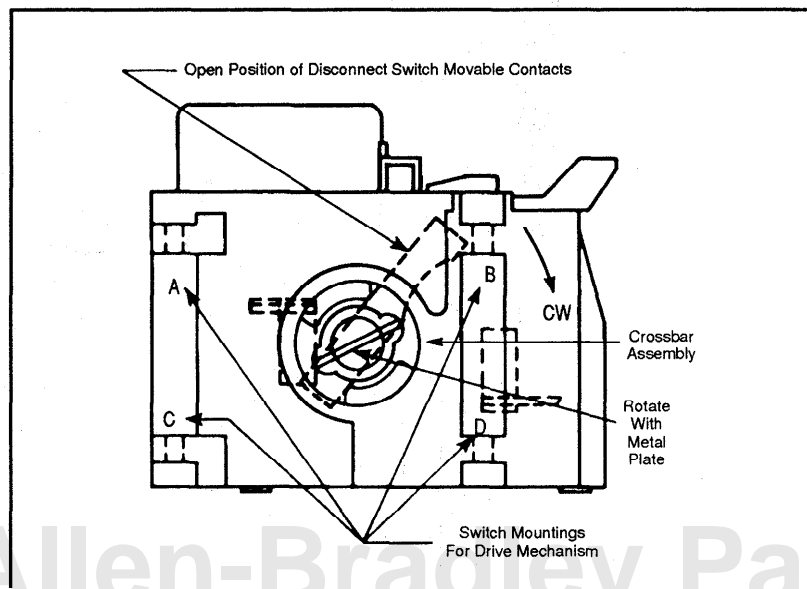

Figure 9

3. Rotate the crossbar assembly in a clockwise direction to the "CLOSED" position. (i.e. full engagement of the movable contacts into the line side stationary contacts as shown in Figure 10.) Use any convenient adjustable wrench or pliers to aid in turning.

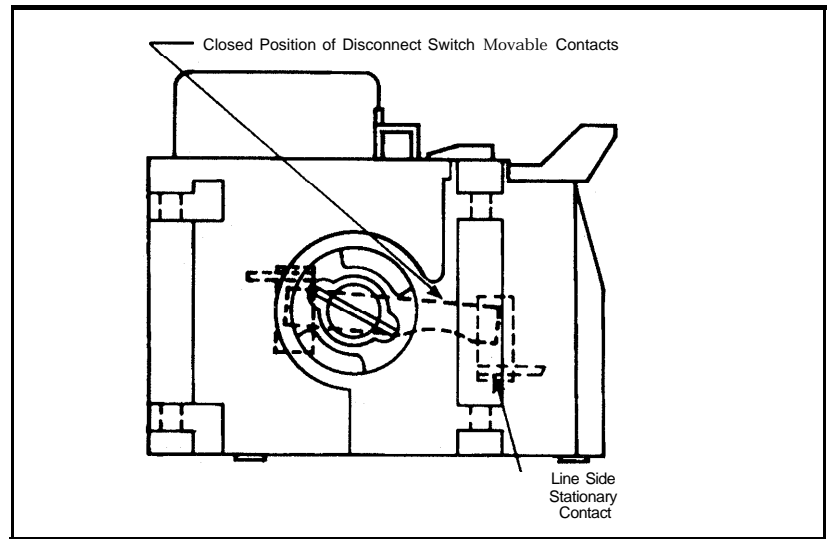

Figure 10

4. Remove the metal plate and dispose of properly, as it is not required for switches operation.
5. Position the drive mechanism as shown in Figure 11.

**NOTE:** Do not attempt to change the position of the drive plate assembly on the drive mechanism (Figure 11).

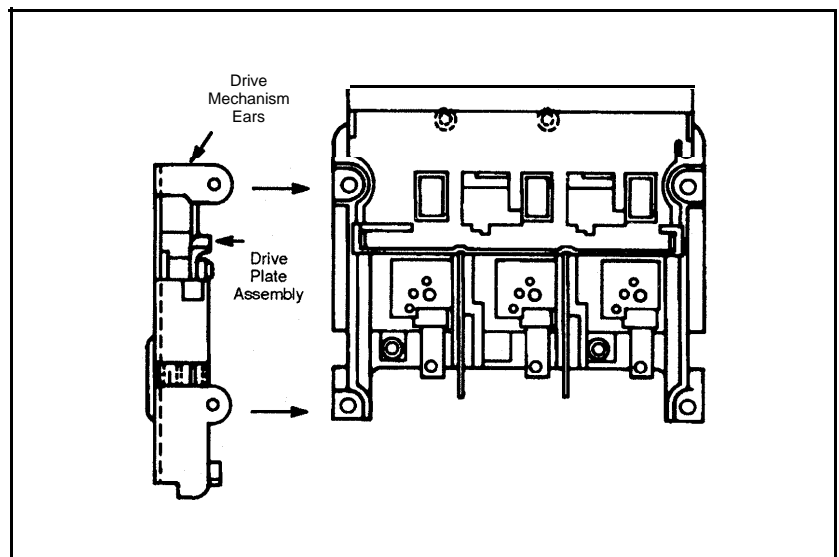

Figure 11

6. Insert the drive mechanism ears between switch mountings A, B, C, D as shown in Figure 9. The drive plate assembly should engage the openings in the crossbar assembly.
7. Fasten with screws removed per Step 1. Torque to 50 lb.-in.
8. Verify that the mounting dimensions for left-hand installation from Figure 1 have been used.
9. Continue with Step 2, on Page 2.

## Instruction Sheet

Variable Depth Flange Operated Disconnect Switches  
30 and 60 Ampere (Series A)



**ALLEN-BRADLEY**  
A ROCKWELL INTERNATIONAL COMPANY

Allen-Bradley has been helping its customer improve productivity and quality for 90 years. Allen-Bradley designs, manufactures and supports a broad range of control and automation products worldwide. They include logic processors, power and motion control devices, man-machine interfaces and sensors. Allen-Bradley is a subsidiary of Rockwell International, one of the world's leading technology companies.

With offices in major cities worldwide.

**WORLD HEADQUARTERS**  
Allen-Bradley  
1201 South Second Street  
Milwaukee, WI 53204 USA  
Tel: (1) 414 382-2000  
Telex: 43 11 016  
Fax: (1) 414 382-4444

**EUROPE/AFRICA  
HEADQUARTERS**  
Allen-Bradley GmbH  
European Commercial Headquarters  
Robert-Bosch-Strasse 5  
6072 Dreieich-Sprendlingen  
Germany  
Tel: (49) 6103-379733  
Fax: (49) 6103-379731

**ASIA/PACIFIC HEADQUARTERS**  
Allen-Bradley  
1201 South Second Street  
Milwaukee, WI 53204 USA  
Tel: (1) 414 382-3269  
Telex: 43 11 016  
Fax: (1) 414 382-4050

**CANADA HEADQUARTERS**  
Allen-Bradley Canada Limited  
135 Dundas Street  
Cambridge, Ontario N1R 5X1  
Canada  
Tel: (1) 519 623-1810  
Fax: (1) 519 623-8930

**LATIN AMERICA  
HEADQUARTERS**  
Allen-Bradley  
1201 South Second Street  
Milwaukee, WI 53204 USA  
Tel: (1) 414 382-2000  
Telex: 43 11 016  
Fax: (1) 414 382-2400