

Bulletin 1318 Connection Guide Terminal Block Connections

- Terminals 1, 2 & 3 "Power Supply" Common for 24V logic (0 Volts).
- Terminals 4, 5, & 6 + 24V DC unregulated power supply. Maximum combined load: 150mA.
- Terminal 7 - 24V DC unregulated power supply. Maximum load: 50mA.
- Terminal 8 + 15V DC regulated power supply.
- Terminal 9 - 15V DC regulated power supply.
- Terminals 10 & 11 + 10V DC regulated power supply. Maximum load: 20mA.
- Terminals 12 & 13 - 10V DC regulated power supply. Maximum load: 20mA.
- Terminals 14,15, & 16 "Signal" Common.
- Terminal 17 Inverse Time Current Limit Output (10V DC @ 2ma = 200% current).
- Terminal 18 Stop under Ramp control (via contact).
- Terminal 19 Zero to + 10V Speed reference input to Ramp circuit.
- Terminal 20 + 24V DC, causes Ramp to reset to zero (regenerate to Zero Speed at current limit) DC Loop contactor does not drop out at Zero Speed.
- Terminal 21 0 to + 10V DC current command (5V DC = 100% Controller current).
- Terminal 22 Jog Disable, connecting to signal common disables Jog reference input
- Terminal 23 Non-Buffered Speed amplifier output (0 to +- 5V DC) through resistor.
- Terminal 24 Reverse current limit program input (5V DC = 100% rated line current).
- Terminal 25 Jog (Crawl) input reference (+ 10V DC = 25% Speed).
- Terminal 26 Speed reference (0 to + 10V DC reference) ramp bypassed.
- Terminal 27 Forward current limit program input (5V DC = 100% rated Drive current).
- Terminal 28 Tachometer feedback input (7.5 to 245V DC maximum) Negative input for forward operation. See following note.
- Note: Verify that resistors are selected correctly in slots R16 and R17 (Applications Board) for tachometer output.
- Terminal 29 Buffered Tachometer output, (0 to + 10V DC = 100% Speed @ 2mA maximum) for speed metering.
- Terminal 30 Current Limit solid state relay output (+ 24V DC = "in Current Limit") maximum load: 45mA.
- Terminal 31 Drive Healthy (Internal Fault Detector Circuit Output) (0V DC = Fault) maximum load: 45mA.
- Terminal 32 Zero Speed Detector Output (+ 24V DC = Zero speed) maximum load: 45mA.
- Terminal 33 Make Ready (Enable) input (+ 24V DC allows the Drive DC Loop contactor to close and activate Drive circuitry when + 24V DC RUN signal is present at terminal 36).

- Terminal 34 DC Loop contactor closed input via auxiliary contact (+ 24V DC = Contactor closed).
- Terminal 35 DC Loop contactor output (+ 24V DC = Contactor closed).
- Terminal 36 Run enable input (+ 24V DC = Run).
- Terminal 37 Trip input (+ 24V DC allows Drive to run. Removing + 24V DC causes Drive to Coast-to-Stop.).
- Terminal 38 Ramp (Accel/Decel) output (0 to + 10V DC). Max Load = 2 mA. Not for Reference follower applications.
- Terminal 39 Stop 3 input (Regenerative Stop) contactor remains closed + 24V DC = OK to run, removing + 24V DC causes Regenerative Stop.
- Terminal 40 Not Used. Do not use as a tie point.
- Terminal 41 Buffered Current Amplifier output (+ 1mA = 200% rated Controller current). For current metering (bi-directional).
- Terminal 42 Buffered Current Amplifier output (+ 1mA = 200% rated controller current). For current metering (unidirectional).
- Terminal 51/53 RL1 Normally Open 115V AC/0.5A Contact.
- Terminal 53/52 RL1 Normally Closed 115V AC/0.5A Contact.
- Terminal 54 RL1 Normally Open 115V AC/0.5A Contact.

100V Wound Field Motors

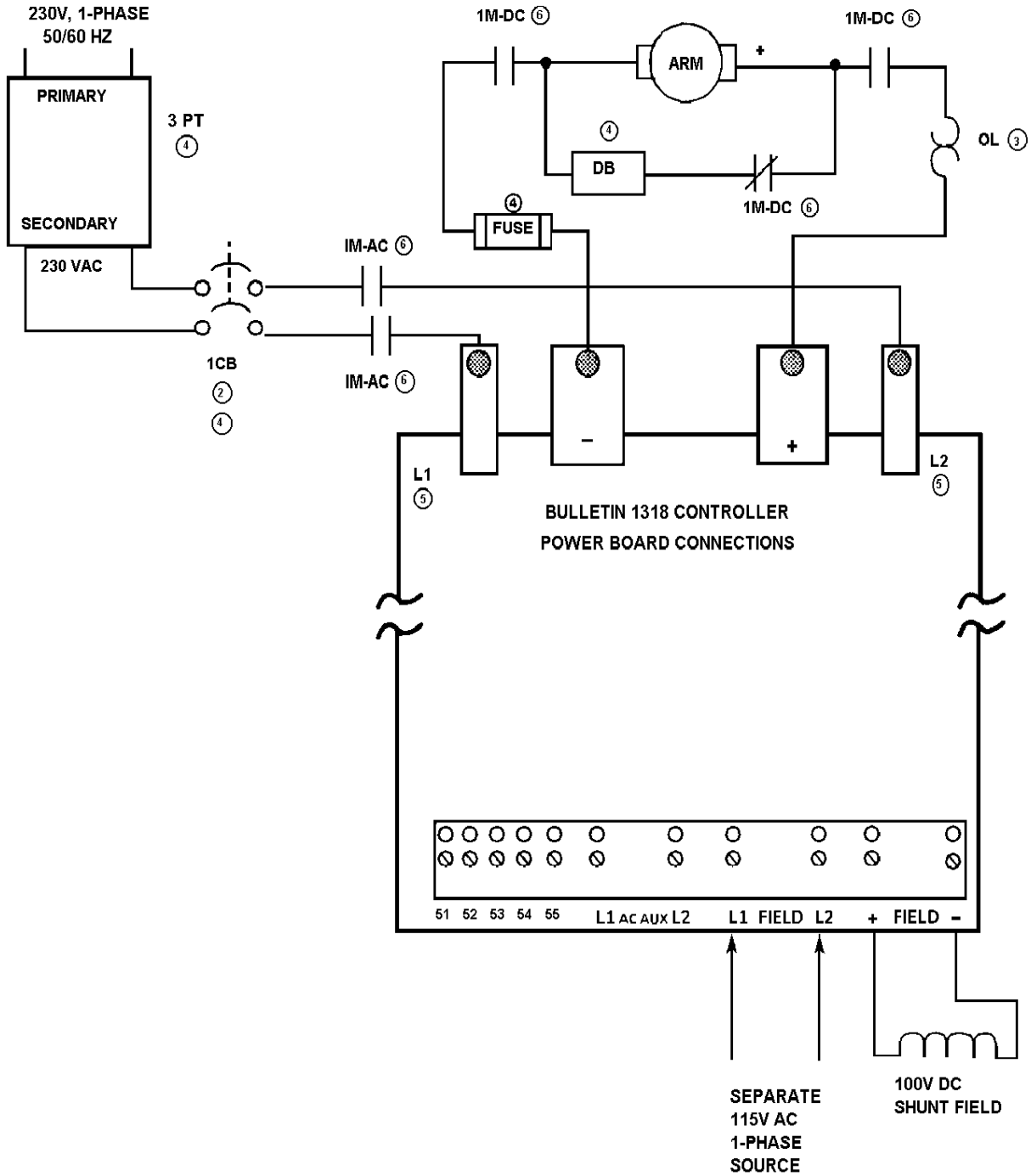

- ② Indicates customer supplied components.
- ③ Recommended DC power loop circuit.
- ④ Indicates optional components.
- ⑤ All L1 and L2 input lines must be "in phase". The input fuses will blow if the "AC AUX" L1 and L2 line inputs are not in phase with the main power L1 and L2 line inputs.
- ⑥ Use an AC or DC contactor. Both are not recommended.

Permanent Magnetic Motors

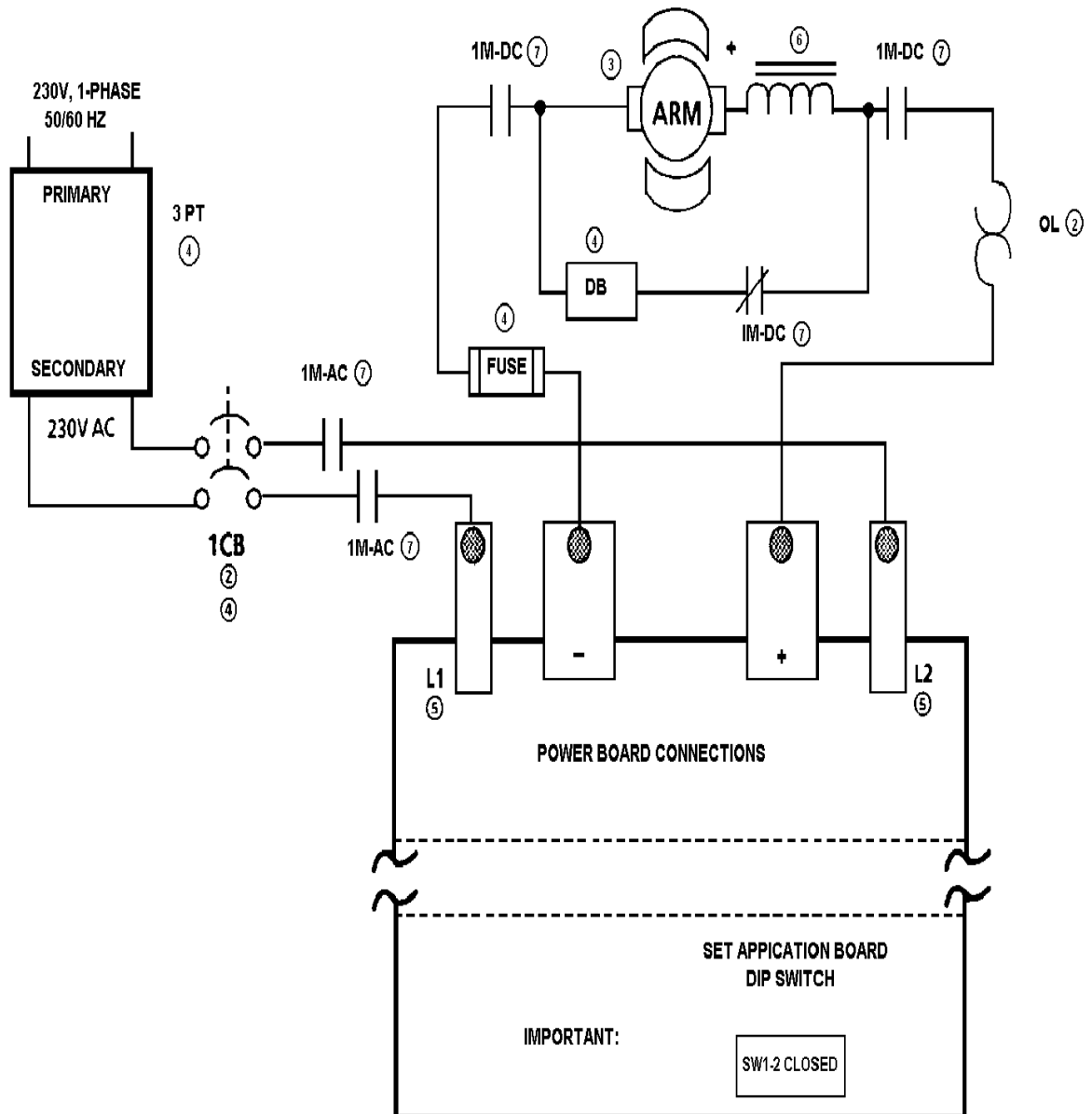

- ② Indicates customer supplied connections.
- ③ Recommended DC power loop circuit.
- ④ Indicates Optional components.
- ⑤ All L1 and L2 input lines must be "in phase". The input line fuses will blow if the "AC AUX" L1 and L2 line inputs are not in phase with the main power L1 and L2 line inputs.
- ⑥ With this type of motor, a smoothing reactor may be required to limit the amount of peak current and guard against permanent magnet damage.
- ⑦ Use an AC or DC contactor. Both are not recommended.

IMPORTANT:

SW1-2 CLOSED

200V Wound Field Motors

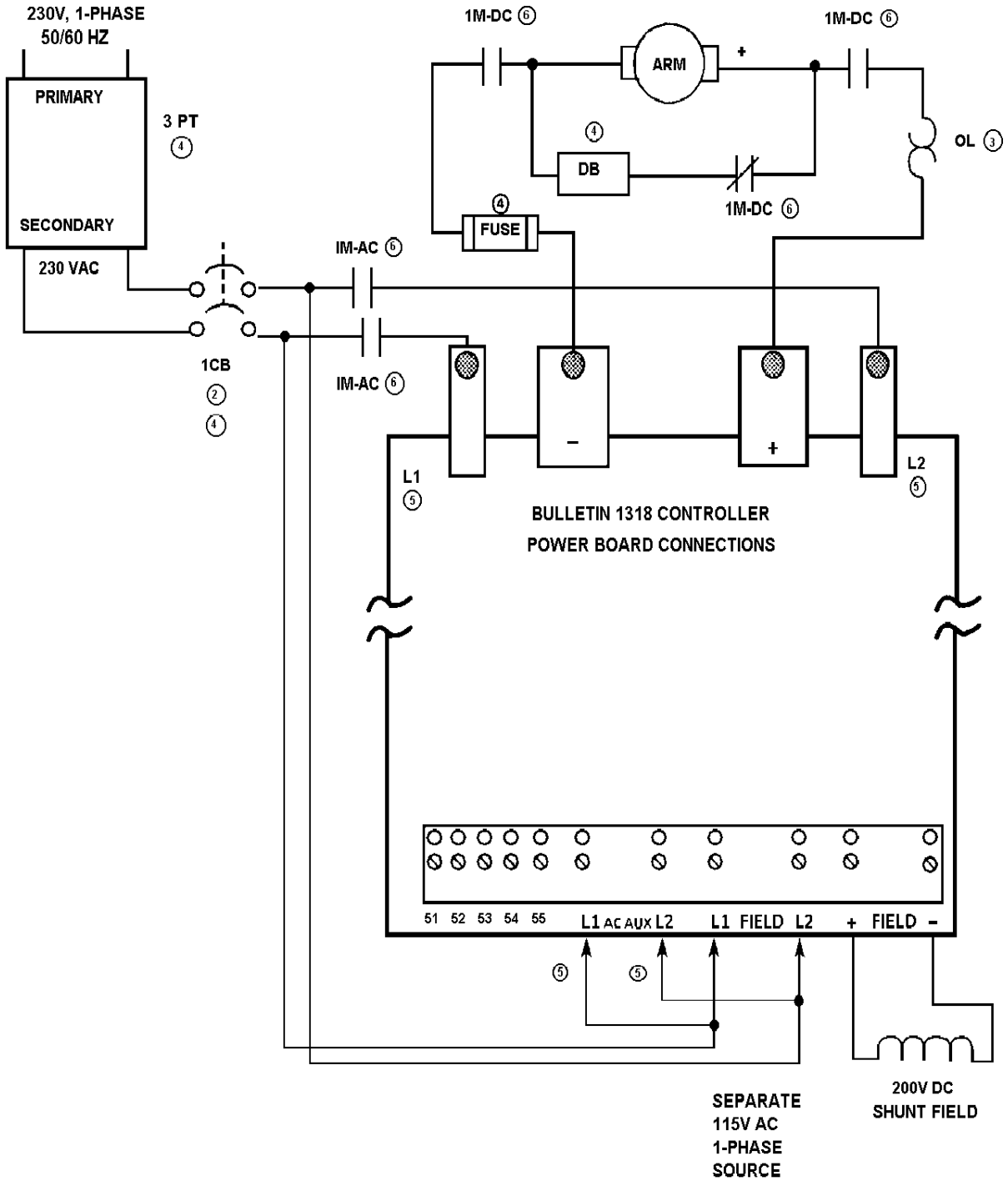

- ② Indicates customer supplied components.
- ③ Recommended DC power loop circuit.
- ④ Indicates optional components.
- ⑤ All L1 and L2 input lines must be "in phase". The input fuses will blow if the "AC AUX" L1 and L2 line inputs are not in phase with the main power L1 and L2 line inputs.
- ⑥ Use an AC or DC contactor. Both are not recommended.

Control Logic Interconnections

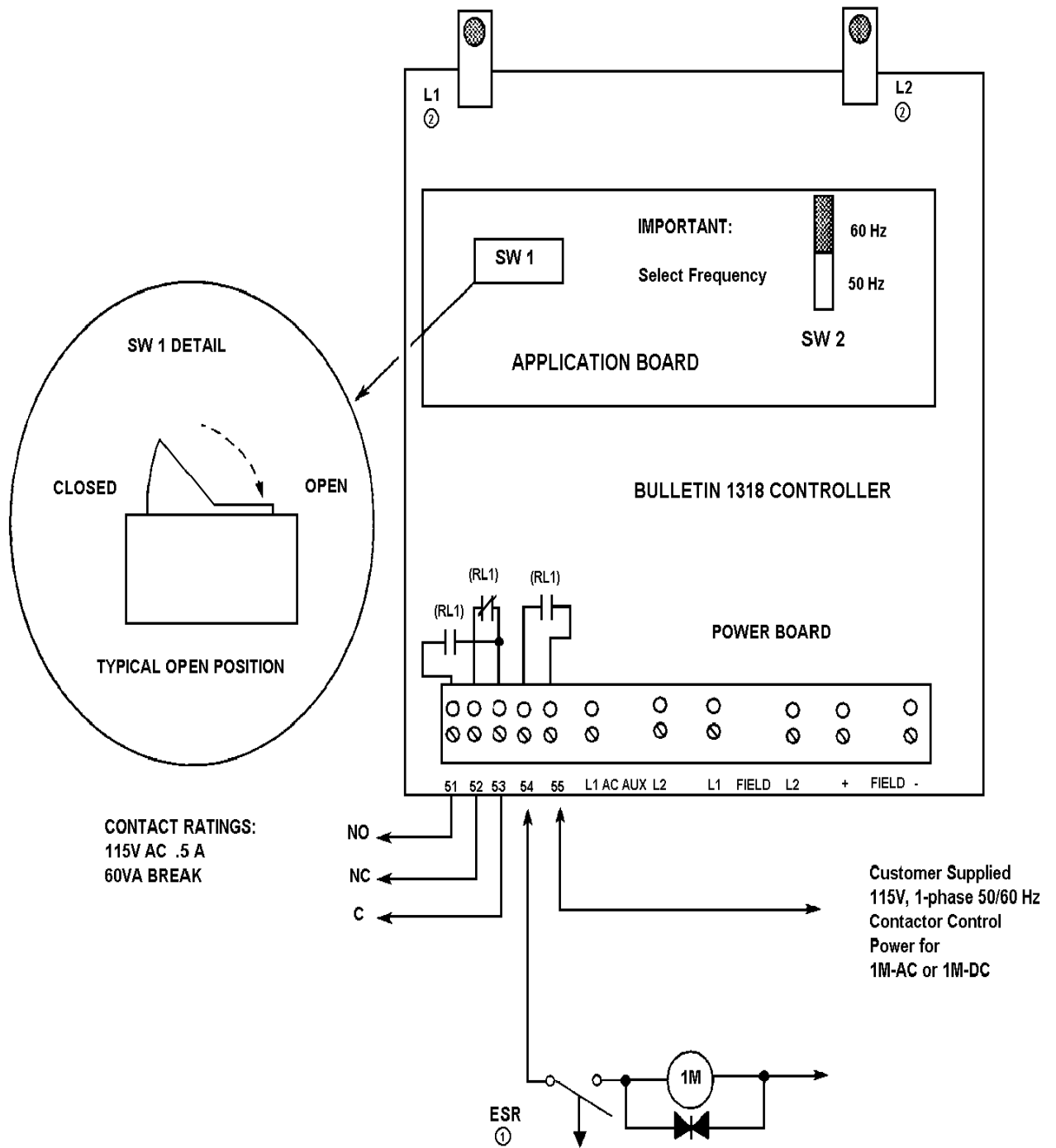

① Indicates customer supplied components.

② All L1 and L2 line inputs must be "in phase". The input line fuses will blow if the "AC AUX" L1 and L2 line inputs are not in phase with the main power L1 and L2 line inputs.

Coast to Stop Control Logic

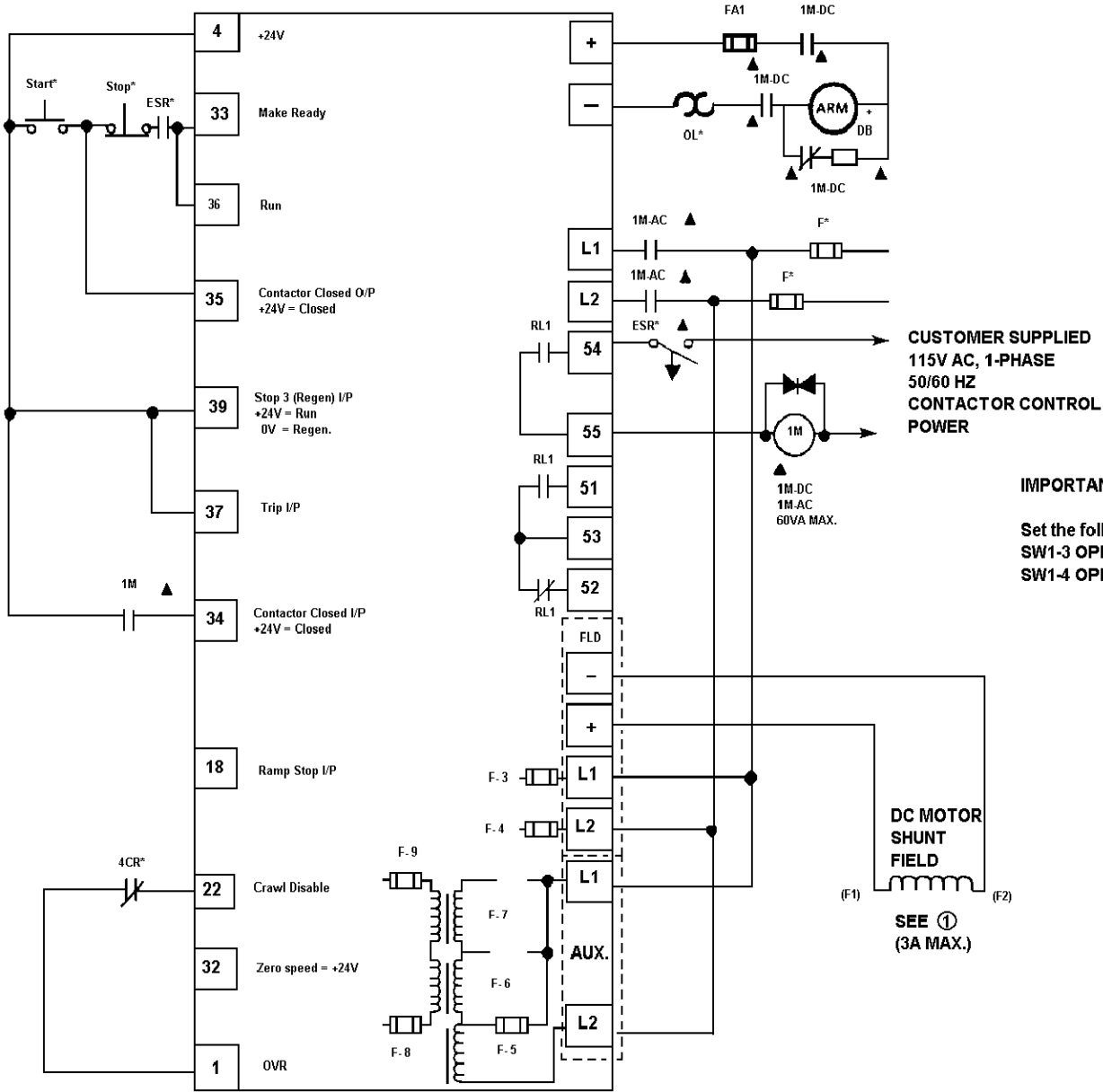

CUSTOMER SUPPLIED
 115V AC, 1-PHASE
 50/60 HZ
 CONTACTOR CONTROL
 POWER

IMPORTANT:
 Set the following switches:
 SW1-3 OPEN
 SW1-4 OPEN

DC MOTOR SHUNT FIELD
 (F1) (F2)
SEE ①
 (3A MAX.)

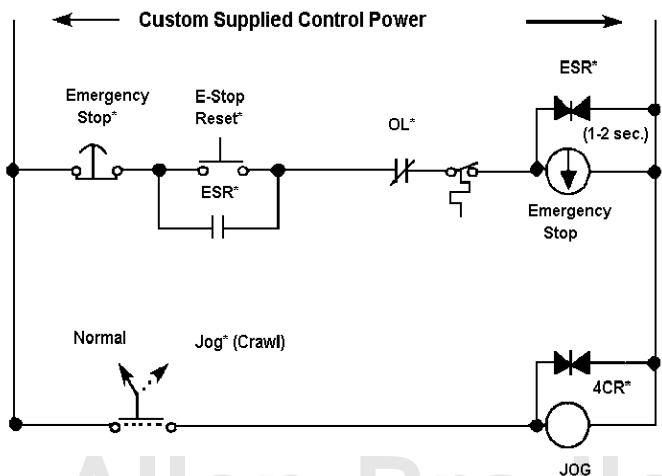

* Indicates component supplied by Allen-Bradley or others. Contacts used in signal circuits must be rated for low power duty.

▲ Indicates optional equipment.

① Typical dual voltage motor field connections are shown below. Consult the motor manufacturer's instructions for correct connections.

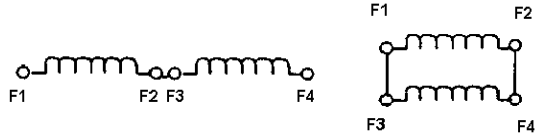

Required Current Limit Stop Control Logic

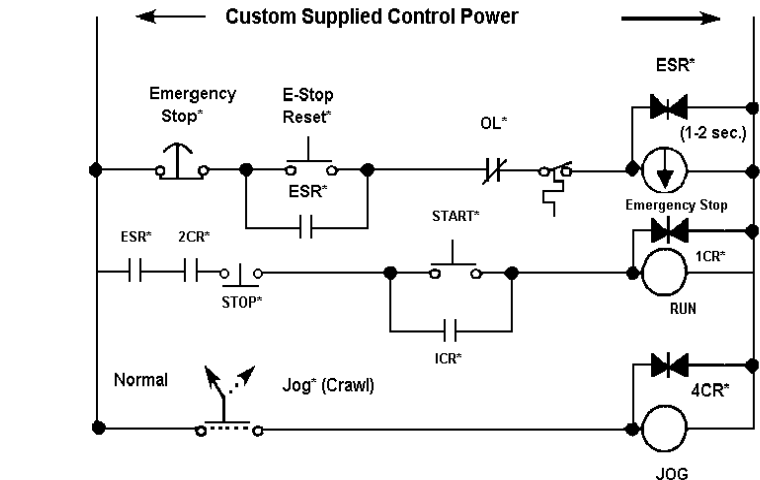
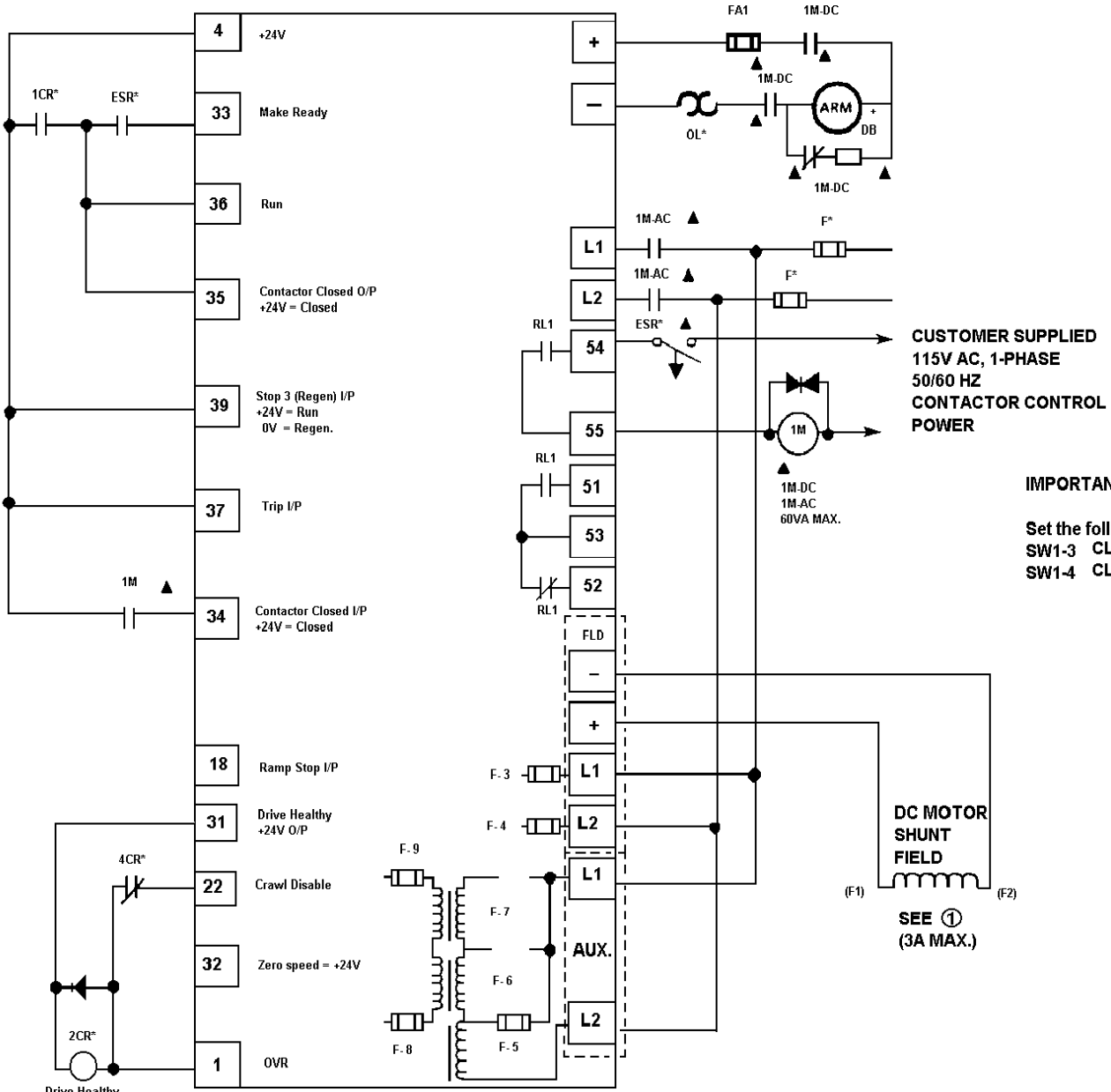

* Indicates component supplied by Allen-Bradley or others. Contacts used in signal circuits must be rated for low power duty.

▲ Indicates optional equipment.

① Typical dual voltage motor field connections are shown below. Consult the motor manufacturer's instructions for correct connections.

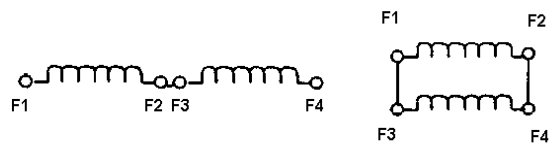

Required Ramp Controlled Stop Control Logic

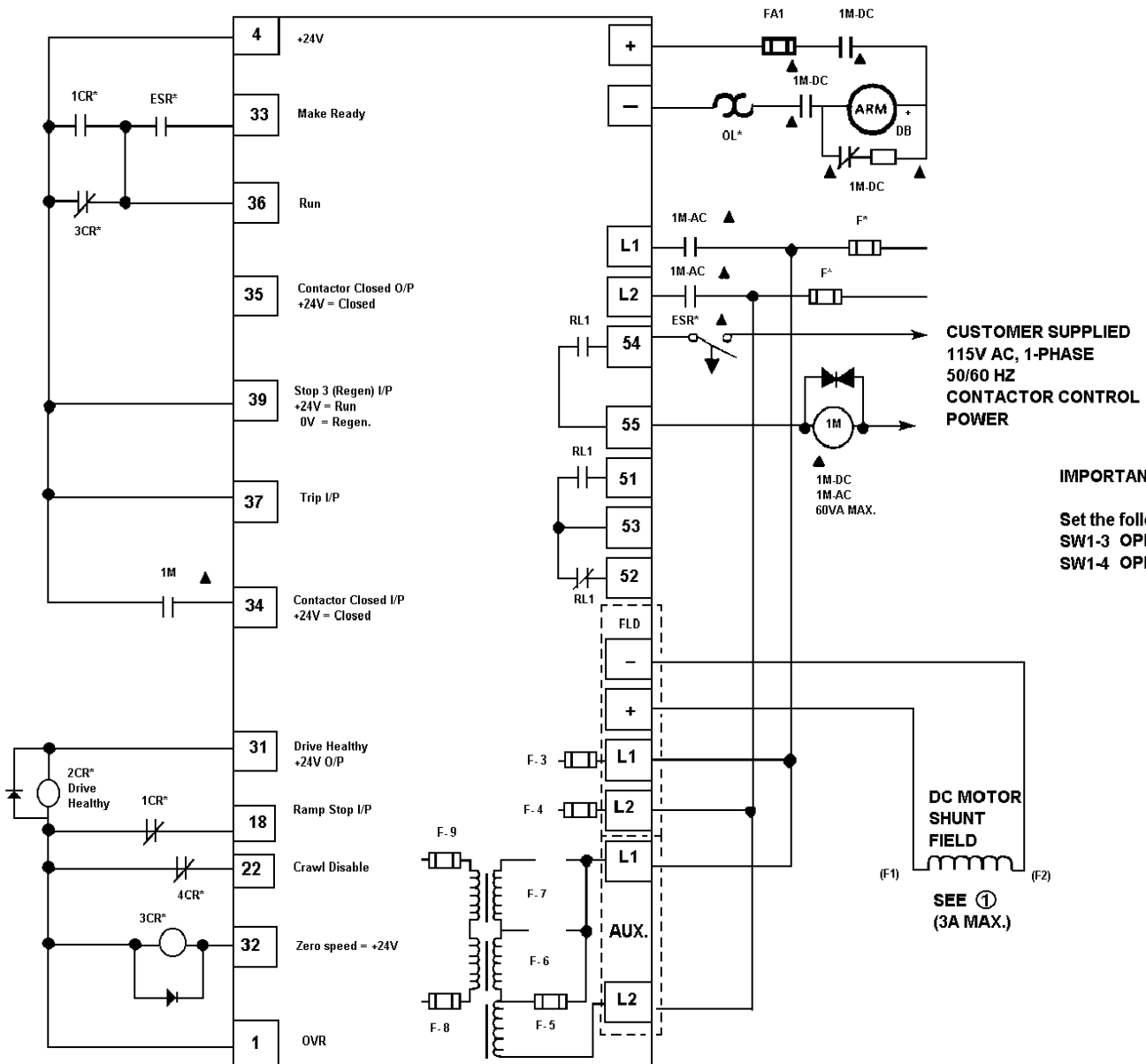

CUSTOMER SUPPLIED
 115V AC, 1-PHASE
 50/60 HZ
 CONTACTOR CONTROL
 POWER

IMPORTANT:
 Set the following switches:
 SW1-3 OPEN
 SW1-4 OPEN

DC MOTOR SHUNT FIELD
 (F1) (F2)
SEE ① (3A MAX.)

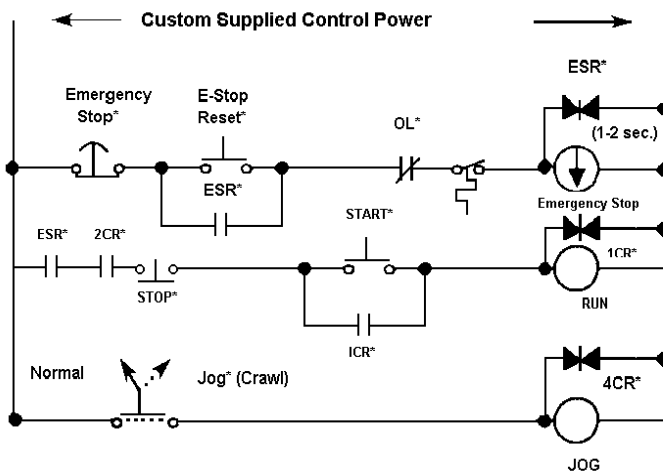

* Indicates component supplied by Allen-Bradley or others. Contacts used in signal circuits must be rated for low power duty.

▲ Indicates optional equipment.

① Typical dual voltage motor field connections are shown below. Consult the motor manufacturer's instructions for correct connections.

