



Installation Instructions

ControlLogix SynchLink Module

Catalog Number 1756-SYNCH

To:	See page:
Identify the Module Components	6
Use Related Publications	6
Note the Power Requirements	6
Install the Module	7
Connect the Fiber Optic Cable	8
Check the Indicators	9
Remove the Module	12
See 1756-SYNCH Specifications	12

Obtain a User Manual

This product also has a user manual (pub. no. 1756-UM521). To view it, visit www.ab.com/manuals or www.theautomationbookstore.com

To purchase a manual, you can:

- contact your distributor or Rockwell Automation representative
- visit www.theautomationbookstore.com and place an order
- call 800.963.9548 (USA/Canada) or 001.320.725.1574 (outside USA/Canada)

AB Drive

Important User Information

Solid state equipment has operational characteristics differing from those of electromechanical equipment. *Safety Guidelines for the Application, Installation and Maintenance of Solid State Controls* (Publication SGI-1.1 available from your local Rockwell Automation sales office or online at <http://www.ab.com/manuals/gi>) describes some important differences between solid state equipment and hard-wired electromechanical devices. Because of this difference, and also because of the wide variety of uses for solid state equipment, all persons responsible for applying this equipment must satisfy themselves that each intended application of this equipment is acceptable.



In no event will Rockwell Automation, Inc. be responsible or liable for indirect or consequential damages resulting from the use or application of this equipment.

The examples and diagrams in this manual are included solely for illustrative purposes. Because of the many variables and requirements associated with any particular installation, Rockwell Automation, Inc. cannot assume responsibility or liability for actual use based on the examples and diagrams.

No patent liability is assumed by Rockwell Automation, Inc. with respect to use of information, circuits, equipment, or software described in this manual.

Reproduction of the contents of this manual, in whole or in part, without written permission of Rockwell Automation, Inc. is prohibited.

Throughout this manual we use notes to make you aware of safety considerations.

WARNING 	Identifies information about practices or circumstances that can cause an explosion in a hazardous environment, which may lead to personal injury or death, property damage, or economic loss.
ATTENTION 	Identifies information about practices or circumstances that can lead to personal injury or death, property damage, or economic loss. Attentions help you: <ul style="list-style-type: none">• identify a hazard• avoid a hazard• recognize the consequence
IMPORTANT	Identifies information that is critical for successful application and understanding of the product.
SHOCK HAZARD 	Labels may be located on or inside the drive to alert people that dangerous voltage may be present.

Environment and Enclosure

ATTENTION

This equipment is intended for use in a Pollution Degree 2 industrial environment, in overvoltage Category II applications (as defined in IEC publication 60664-1), at altitudes up to 2000 meters without derating.

This equipment is considered Group 1, Class A industrial equipment according to IEC/CISPR Publication 11. Without appropriate precautions, there may be potential difficulties ensuring electromagnetic compatibility in other environments due to conducted as well as radiated disturbance.

This equipment is supplied as "open type" equipment. It must be mounted within an enclosure that is suitably designed for those specific environmental conditions that will be present and appropriately designed to prevent personal injury resulting from accessibility to live parts. The interior of the enclosure must be accessible only by the use of a tool. Subsequent sections of this publication may contain additional information regarding specific enclosure type ratings that are required to comply with certain product safety certifications.

NOTE: See NEMA Standards publication 250 and IEC publication 60529, as applicable, for explanations of the degrees of protection provided by different types of enclosure. Also, see the appropriate sections in this publication, as well as the Allen-Bradley publication 1770-4.1 ("Industrial Automation Wiring and Grounding Guidelines"), for additional installation requirements pertaining to this equipment.

Prevent Electrostatic Discharge

ATTENTION

This equipment is sensitive to electrostatic discharge, which can cause internal damage and affect normal operation. Follow these guidelines when you handle this equipment:

- Touch a grounded object to discharge potential static.
- Wear an approved grounding wriststrap.
- Do not touch connectors or pins on component boards.
- Do not touch circuit components inside the equipment.
- If available, use a static-safe workstation.

When not in use, store the equipment in appropriate static-safe packaging.

Removal and Insertion Under Power

WARNING

When you insert or remove the module while backplane power is on, an electrical arc can occur. This could cause an explosion in hazardous location installations.

Be sure that power is removed or the area is nonhazardous before proceeding. Repeated electrical arcing causes excessive wear to contacts on both the module and its mating connector. Worn contacts may create electrical resistance that can affect module operation.



North American Hazardous Location Approval

The following information applies when operating this equipment in hazardous locations:

Products marked "CL I, DIV 2, GP A, B, C, D" are suitable for use in Class I Division 2 Groups A, B, C, D, Hazardous Locations and nonhazardous locations only. Each product is supplied with markings on the rating nameplate indicating the hazardous location temperature code. When combining products within a system, the most adverse temperature code (lowest "T" number) may be used to help determine the overall temperature code of the system. Combinations of equipment in your system are subject to investigation by the local Authority Having Jurisdiction at the time of installation.

Informations sur l'utilisation de cet équipement en environnements dangereux :

Les produits marqués "CL I, DIV 2, GP A, B, C, D" ne conviennent qu'à une utilisation en environnements de Classe I Division 2 Groupes A, B, C, D dangereux et non dangereux. Chaque produit est livré avec des marquages sur sa plaque d'identification qui indiquent le code de température pour les environnements dangereux. Lorsque plusieurs produits sont combinés dans un système, le code de température le plus défavorable (code de température le plus faible) peut être utilisé pour déterminer le code de température global du système. Les combinaisons d'équipements dans le système sont sujettes à inspection par les autorités locales qualifiées au moment de l'installation.

The following information applies when operating this equipment in hazardous locations:	Informations sur l'utilisation de cet équipement en environnements dangereux :
<p>WARNING</p>  <p>EXPLOSION HAZARD</p> <ul style="list-style-type: none"> Do not disconnect equipment unless power has been removed or the area is known to be nonhazardous. Do not disconnect connections to this equipment unless power has been removed or the area is known to be nonhazardous. Secure any external connections that mate to this equipment by using screws, sliding latches, threaded connectors, or other means provided with this product. Substitution of components may impair suitability for Class I, Division 2. If this product contains batteries, they must only be changed in an area known to be nonhazardous. 	<p>AVERTISSEMENT</p>  <p>RISQUE D'EXPLOSION</p> <ul style="list-style-type: none"> Couper le courant ou s'assurer que l'environnement est classé non dangereux avant de débrancher l'équipement. Couper le courant ou s'assurer que l'environnement est classé non dangereux avant de débrancher les connecteurs. Fixer tous les connecteurs externes reliés à cet équipement à l'aide de vis, loquets coulissants, connecteurs filetés ou autres moyens fournis avec ce produit. La substitution de composants peut rendre cet équipement inadapté à une utilisation en environnement de Classe I, Division 2. S'assurer que l'environnement est classé non dangereux avant de changer les piles.

AB Drive

Identify the Module Components

You should have received a 1756-SYNCH module with your order. If you did not receive these components, contact your Rockwell Automation sales office.

This module mounts in a ControlLogix™ chassis and connects to other ControlLogix chassis through a fiber optic cable (Catalog number 1403-CFxxx, where xxx = cable length. For example, catalog number 1403-CF001 is a 1 meter cable.)

Use Related Publications

Publication title	Publication number
SynchLink Base Block installation instructions	1751-IN001
SynchLink 4-port Splitter Block installation instructions	1751-IN002
SynchLink Bypass Switch Block installation instructions	1751-IN003
SynchLink system overview	1756-S0008
ControlLogix SynchLink module user manual	1756-UM521

Note the Power Requirements

This module receives power from the 1756 chassis power supply and requires 2 sources of power from the backplane:

- 1200mA at 5.1V dc
- 3mA at 24V dc

Add this current/power value (6.19W) to the requirements of all other modules in the chassis to prevent overloading the power supply.

Install the Module

You can install or remove the module while chassis power is applied.

WARNING

When you insert or remove the module while backplane power is on, an electrical arc can occur. This could cause an explosion in hazardous location installations.

Be sure that power is removed or the area is nonhazardous before proceeding. Repeated electrical arcing causes excessive wear to contacts on both the module and its mating connector. Worn contacts may create electrical resistance that can affect module operation.

1. Align the circuit board with the top and bottom chassis guides.

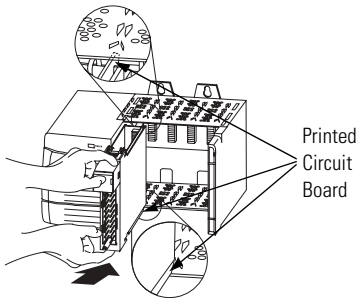

20861-M

2. Slide the module into chassis until module locking tabs click.

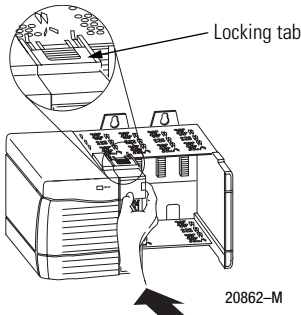

20862-M

AB Drive

Connect the Fiber Optic Cable

The front port of you 1756-SYNCH module receives data, and the rear port transmits data. Connect the fiber optic cables as shown below.

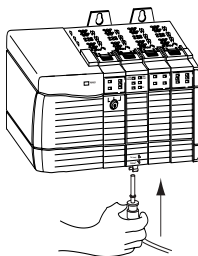

ATTENTION



Do not look directly into the fiber ports or fiber cables. Light levels may cause damage to eyesight. The SynchLink module is a Class I LED product.

Table 1 lists the possible connections that might be made to your 1756-SYNCH module and where to connect the fiber optic cable.

Table 1

If your 1756-SYNCH module:	Make theses fiber optic cable connections:
transmits data only	<ol style="list-style-type: none"> 1. Connect the fiber optic cable to the rear port. 2. Connect the other end of the cable to a module receiving data from this module.
receives data only	<ol style="list-style-type: none"> 1. Connect the fiber optic cable to the front port. 2. Connect the other end of the cable to a device transmitting data to this module.
transmits and receives data	<ol style="list-style-type: none"> 1. Connect the fiber optic cable transmitting data to another module to the front port. 2. Connect the fiber optic cable receiving data from another module to the rear port.

Check the Indicators

The indicators show SynchLink and ControlBus status (red/green) and a bi-colored LED for module "OK" (red/green).

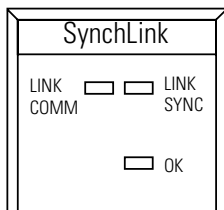

During power up, an indicator test is done and the following occurs:

- The "OK" indicator turns red for 1 second and then turns to flashing green if it has passed the self-test.

Use the table below to troubleshoot your module.

LED indicators:	This display:	Means:	Take this action:
COMM	Steady green light	The module is configured and operating properly.	None
COMM	Off	<ol style="list-style-type: none"> 1. The module is not powered. 2. The module is not configured. 3. The module is configured to receive data from SynchLink but did not receive it in the last scan. 4. The module is configured to transmit on SynchLink but has not enabled its transmitter. 5. The Transmit and Receive communications formats do not match between linked modules. 	<ol style="list-style-type: none"> 1. Power the module. 2. Configure the module. 3. Check fiber connections and diagnostic counter for errors. If the problem persists, replace the module. 4. Make sure configuration is complete and downloaded. If the problem persists, replace the module. 5. In RSLogix 5000, make sure communications formats match between linked modules.

10 ControlLogix SynchLink Module

LED indicators:	This display:	Means:	Take this action:
SYNC	Steady green light	The module is the time master or a time relay and synchronization is complete.	None
SYNC	Flashing green light	The module is configured: <ul style="list-style-type: none"> • to be a time relay from SynchLink to chassis backplane. • with the <i>Dependence on SynchLink</i> feature set to <i>Not Required</i> or <i>Ignored</i>. but has not synchronized with the upstream device.	Check configuration and make sure all modules in the system are online.
SYNC	Flashing red light	<ol style="list-style-type: none"> 1. The module is configured as the CST time master and has detected another CST time master. 2. The configuration information received from SynchLink does not match the module's configuration. 3. The module is configured as time master on SynchLink and has received time information from another time master on SynchLink. 	<ol style="list-style-type: none"> 1. Check configuration throughout the system and verify there is only one CST time master. 2. Check configuration of this module and all upstream SynchLink devices. 3. Check configuration for all modules in the system to make sure only one is the SynchLink time master.

LED indicators:	This display:	Means:	Take this action:
SYNC	Off	<ol style="list-style-type: none"> The module is not powered. The module is not configured as time master or time relay. The module is configured as a time relay from chassis backplane to SynchLink but is not synchronized with a CST master on the backplane. The module is configured: <ul style="list-style-type: none"> to be a time relay from SynchLink to chassis backplane. with the <i>Dependence on SynchLink</i> feature set to <i>Required</i>. but has not synchronized with the upstream device. 	<ol style="list-style-type: none"> Power the module. Configure the module for its proper function. Establish a CST master on the backplane. Check configuration and make sure all modules in the system are online.
OK	Steady green light	The module is operating properly.	None
OK	Flashing green light	The module is powered and ready for operation but has not received configuration.	Configure the module.
OK	Steady red light	The module has experienced an unrecoverable error.	Replace the module.
OK	Flashing red light	A flash upgrade is in process.	Wait for upgrade to finish. New code may be needed.
OK	Off	The module is not powered.	Power the module, if needed.

This completes installation of the module. Use the information below to remove the module.

Remove the Module

Before you remove the module, disconnect the fiber optic cable.

1. Push in top and bottom locking tabs.

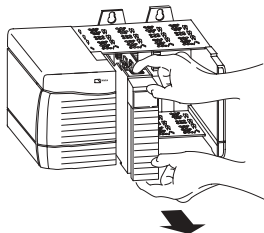

20808-M

2. Pull module out of the chassis.

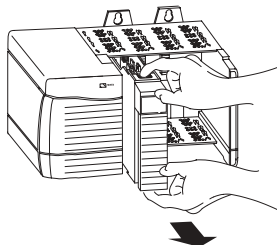

20857-M

1756-SYNCH Specifications

General Specifications	
Module Location	1756 ControlLogix chassis
Backplane Current	1200mA @ 5.1V dc & 3mA @ 24V dc
Maximum Power Dissipation	6.19W
Thermal Dissipation	21.1 BTU/hr
Connecting Cable	
Fiber Type	200/230 micron Hard Clad Silica (HCS),
Fiber Termination Type	Versalink V-System
Assemblies	Order from Rockwell Automation under catalog number 1403-CFxxx or use the Lucent Technologies HCP-M0200T V01RK 200µm simplex cable
Maximum Length	300m
Minimum Length	1m
Operating Wavelength	650nm (red)
SynchLink Data Rate	5Mbps
Baud Rate	5Mbaud

Type of Communication	Synchronous
Frame Period	50 μ s
Indicators	Green and red indicators for operation, status and diagnostics
Frame Parameters	3 Flags - 3 bytes Control field - 1 byte Data field - 24 bytes CRC field - 2 bytes

Environmental Conditions

Operational Temperature	IEC 60068-2-1 (Test Ad, Operating Cold), IEC 60068-2-2 (Test Bd, Operating Dry Heat), IEC 60068-2-14 (Test Nb, Operating Thermal Shock): 0 to 60°C (32 to 140°F)
Storage Temperature	IEC 60068-2-1 (Test Ab, Un-packaged Non-operating Cold), IEC 60068-2-2 (Test Bb, Un-packaged Non-operating Dry Heat), IEC 60068-2-14 (Test Na, Un-packaged Non-operating Thermal Shock): -40 to 85°C (-40 to 185°F)
Relative Humidity	IEC 60068-2-30 (Test Db, Un-packaged Non-operating Damp Heat): 5 to 95% non-condensing
Vibration	IEC 60068-2-6 (Test Fc, Operating): 2g @ 10-500Hz
Operating Shock	IEC 60068-2-27 (Test Ea, Unpackaged Shock): 30g
Non-operating Shock	IEC 60068-2-27 (Test Ea, Unpackaged Shock): 50g
Emissions	CISPR 11: Group 1, Class A
ESD Immunity	IEC 61000-4-2: 6kV contact discharges 8kV air discharges

14 ControlLogix SynchLink Module

Radiated RF Immunity	IEC 61000-4-3: 10V/m with 1kHz sine-wave 80%AM from 30MHz to 1000MHz 10V/m with 200Hz 50% Pulse 100%AM at 900Mhz
EFT/B Immunity	IEC 61000-4-4: ±4kV at 2.5kHz on power ports
Conducted RF Immunity	IEC 61000-4-6: 10Vrms with 1kHz sine-wave 80%AM from 150kHz to 80MHz
Enclosure Type Rating	None (open-style)
Certifications: (when product is marked)	UL UL Listed Industrial Control Equipment CSA CSA Certified Process Control Equipment CSA CSA Certified Process Control Equipment for Class I, Division 2 Group A,B,C,D Hazardous Locations CE ⁽¹⁾ European Union 89/336/EEC EMC Directive, compliant with: EN 50082-2; Industrial Immunity EN 61326; Meas./Control/Lab., Industrial Requirements EN 61000-6-2; Industrial Immunity EN 61000-6-4; Industrial Emissions C-Tick ⁽¹⁾ Australian Radiocommunications Act, compliant with: AS/NZS CISPR 11; Industrial Emissions

⁽¹⁾ See the Product Certification link at www.ab.com for Declarations of Conformity, Certificates, and other certification details.

Notes:

AB Drive

Rockwell Automation Support

Rockwell Automation provides technical information on the web to assist you in using our products. At <http://support.rockwellautomation.com>, you can find technical manuals, a knowledge base of FAQs, technical and application notes, sample code and links to software service packs, and a MySupport feature that you can customize to make the best use of these tools.

For an additional level of technical phone support for installation, configuration and troubleshooting, we offer TechConnect Support programs. For more information, contact your local distributor or Rockwell Automation representative, or visit <http://support.rockwellautomation.com>.

Installation Assistance

If you experience a problem with a hardware module within the first 24 hours of installation, please review the information that's contained in this manual. You can also contact a special Customer Support number for initial help in getting your module up and running:

United States	1.440.646.3223 Monday – Friday, 8am – 5pm EST
Outside United States	Please contact your local Rockwell Automation representative for any technical support issues.

New Product Satisfaction Return

Rockwell tests all of our products to ensure that they are fully operational when shipped from the manufacturing facility. However, if your product is not functioning and needs to be returned:

United States	Contact your distributor. You must provide a Customer Support case number (see phone number above to obtain one) to your distributor in order to complete the return process.
Outside United States	Please contact your local Rockwell Automation representative for return procedure.

www.rockwellautomation.com

Corporate Headquarters

Rockwell Automation, 777 East Wisconsin Avenue, Suite 1400, Milwaukee, WI, 53202-5302 USA, Tel: (1) 414.212.5200, Fax: (1) 414.212.5201

Headquarters for Allen-Bradley Products, Rockwell Software Products and Global Manufacturing Solutions

Americas: Rockwell Automation, 1201 South Second Street, Milwaukee, WI 53204-2496 USA, Tel: (1) 414.382.2000, Fax: (1) 414.382.4444
Europe: Rockwell Automation SA/NV, Vorstlaan/Boulevard du Souverain 36-BP 3A/B, 1170 Brussels, Belgium, Tel: (32) 2 663 0600, Fax: (32) 2 663 0640
Asia Pacific: Rockwell Automation, 27/F Citicorp Centre, 18 Whitfield Road, Causeway Bay, Hong Kong, Tel: (852) 2887 4788, Fax: (852) 2508 1846

Headquarters for Dodge and Reliance Electric Products

Americas: Rockwell Automation, 6040 Ponders Court, Greenville, SC 29615-4617 USA, Tel: (1) 864.297.4800, Fax: (1) 864.281.2433
Europe: Rockwell Automation, Brühlstraße 22, D-74834 Elztal-Dallau, Germany, Tel: (49) 6261 9410, Fax: (49) 6261 17741
Asia Pacific: Rockwell Automation, 55 Newton Road, #11-01/02 Revenue House, Singapore 307987, Tel: (65) 351 6723, Fax: (65) 355 1733

Publication 1756-IN575B-EN-P - September 2003

PN 957831-62

Supersedes Publication 1756-IN575A-EN-P - June 2001

Copyright © 2003 Rockwell Automation, Inc. All rights reserved. Printed in the U.S.A.