



ControlLogix AC (74-132V) Diagnostic Output Module

(Catalog Number 1756-0A8D)

To:	See page:
Prevent Electrostatic Discharge	2
See Removal and Insertion Under Power (RIUP)	2
Understand Compliance to European Union Directive	3
Note the Power Requirements	4
Identify the Module Components	4
Install the Module	5
Key the Removable Terminal Block/Interface Module	6
Wire the Removable Terminal Block	7
Assemble the Removable Terminal Block and the Housing	9
Install the Removable Terminal Block onto the Module	10
Check the Indicators	11
Remove the Removable Terminal Block from the Module	12
Remove the Module	12
See Specifications	13
Understand CSA Hazardous Location Approval	14

This module mounts in a ControlLogix™ chassis and uses a Removable Terminal Block (RTB) or a Bulletin 1492 Interface Module (IFM) to connect all field-side wiring.

When using an IFM to wire your module, consult the installation instructions that came with it to connect all wiring.

Before you install your module you should have already:

- installed and grounded a 1756 chassis and power supply.
- ordered and received an RTB or IFM and its components for your application.

Prevent Electrostatic Discharge

ATTENTION



Electrostatic discharge can damage integrated circuits or semiconductors if you touch backplane connector pins. Follow these guidelines when you handle the module:

- Touch a grounded object to discharge static potential.
 - Wear an approved wrist-strap grounding device.
 - Do not touch the backplane connector or connector pins.
 - Do not touch circuit components inside the module.
 - If available, use a static-safe work station.
 - When not in use, keep the module in its static-shield box.
-

Removal and Insertion Under Power (RIUP)

ATTENTION



This module is designed so you can remove and insert it under backplane power and field-side power. When you remove or insert a module while field-side power is applied, you may cause an electrical arc. An electrical arc can cause personal injury or property damage because it may:

- send an erroneous signal to your system's field devices, causing unintended machine motion or loss of process control.
- cause an explosion in a hazardous environment.

Repeated electrical arcing causes excessive wear to contacts on both the module and its mating connector. Worn contacts may create electrical resistance.

Understand Compliance to European Union Directive

If this product bears the CE marking, it is approved for installation within the European Union and EEA regions. It has been designed and tested to meet the following directives.

EMC Directive

This product is tested to meet Council Directive 89/336/EEC Electromagnetic Compatibility (EMC) and the following standards, in whole or in part, documented in a technical construction file:

- EN 50081-2 EMC - Generic Emission Standard, Part 2 - Industrial Environment
- EN 50082-2 EMC - Generic Immunity Standard, Part 2 - Industrial Environment

This product is intended for use in an industrial environment.

Low Voltage Directive

This product is tested to meet Council Directive 73/23/EEC Low Voltage, by applying the safety requirements of EN 61131-2 Programmable Controllers, Part 2 - Equipment Requirements and Tests.

For specific information required by EN 61131-2, see the appropriate sections in this publication, as well as the following Allen-Bradley publications:

- Industrial Automation Wiring and Grounding Guidelines For Noise Immunity, publication 1770-4.1
- Automation Systems Catalog, publication B111

This equipment is classified as open equipment and must be installed (mounted) in an enclosure during operation as a means of providing safety protection.

Note the Power Requirements

This module receives power from the 1756 chassis power supply and requires 2 sources of power from the backplane:

- 175mA at 5.1V dc
- 250mA at 24V dc

Add this current to the requirements of all other modules in the chassis to prevent overloading the chassis backplane.

Identify the Module Components

You received the following components with your order:

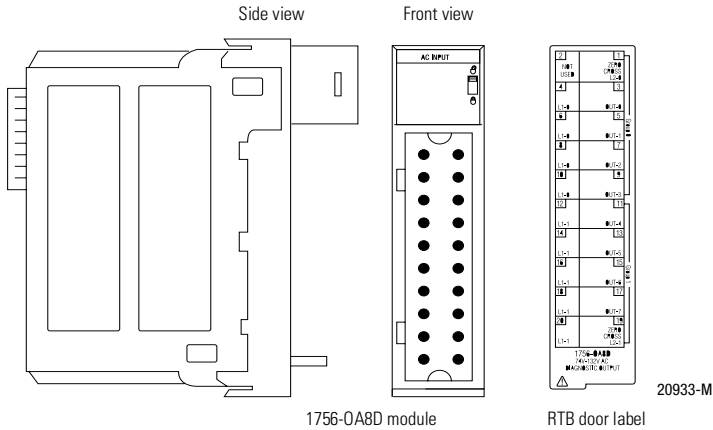

If you did not receive these components, contact your local Rockwell Automation sales office.

Removable Terminal Block and Housing

A separately-ordered RTB connects field-side wiring to the module. You cannot use your module without an RTB and its components.

Use one of the following RTBs with your module:

- 1756-TBNH 20 position NEMA RTB
- 1756-TBSH 20 position Spring Clamp RTB

You received the following components with your RTB:

- standard-depth RTB housing
- wedge-shaped keying tabs and U-shaped keying bands
- a generic RTB door label

Use these components in all module applications. Use an optional extended-depth cover (1756-TBE) for applications requiring heavy gauge wiring.

Install the Module

You can install or remove the module while chassis power is applied.

ATTENTION



The module is designed to support Removal and Insertion Under Power (RIUP). However, when you remove or insert an RTB with field-side power applied, **unintended machine motion or loss of process control can occur**. Exercise extreme caution when using this feature.

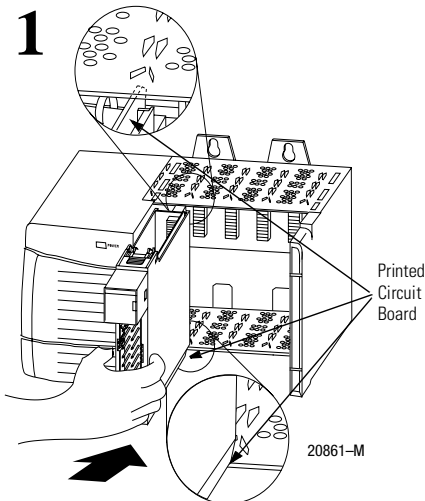

Align circuit board with top and bottom chassis guides.

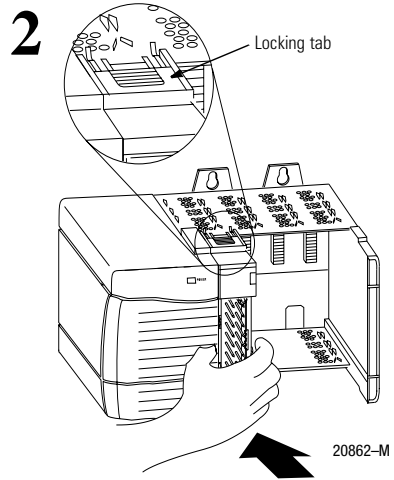

Slide module into chassis until module tabs 'click'.

Key the Removable Terminal Block/Interface Module

Key the RTB or IFM to prevent inadvertently making the wrong wire connections to your module. Use a unique keying pattern for each module. You can use a minimum of one key.

1. Key the module. Insert the U-shaped band with the longer side near the terminals. Push the band onto the module until it snaps into place.

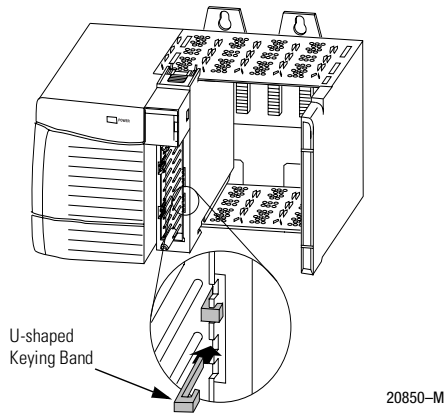

2. Key the RTB in positions that correspond to unkeyed module positions. Insert the wedge-shaped tab on the RTB with the rounded edge first. Push the tab onto the RTB until it stops.

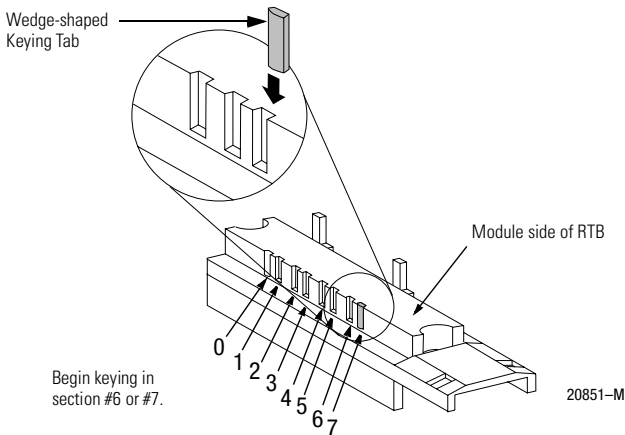

Reposition the tabs to rekey future module applications.

Wire the Removable Terminal Block

Wire the RTB before installing it onto the module. Use a 5/16 inch (8mm) maximum flat-bladed screwdriver.

IMPORTANT: Pull the housing off of the RTB before wiring.

For the Spring Clamp RTB

Strip 7/16 inch (11mm) maximum length to wire your RTB.

1. Insert the screwdriver into the inner hole of the RTB.
2. Insert the wire into the open terminal and remove the screwdriver.

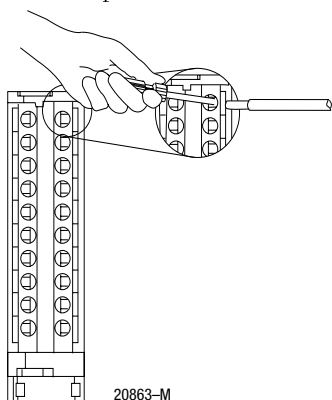

For the NEMA Screw RTB

Strip 5/16 inch (8mm) maximum length to wire your RTB.

Wire the terminals.

Wiring example

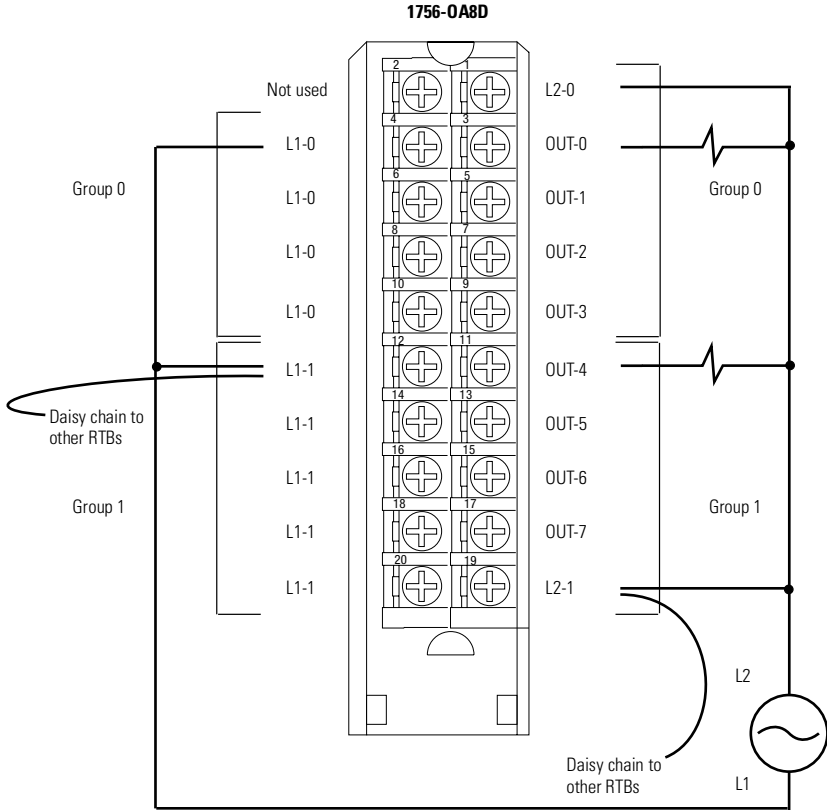

NOTES: All terminals with the same name are connected together on the module.
For example, L1 can be connected to any terminal marked L1-0.

When you daisy chain from a group to another RTB, always connect the daisy chain to the terminal directly connected to the supply wire, as shown above.

This wiring example shows a single voltage source.

40185-M

After field-side wiring is complete, secure the wires in the strain relief area with a cable-tie.

Assemble the Removable Terminal Block and the Housing

1. Align the grooves at the bottom of each side of the housing with the side edges of the RTB.
2. Slide the RTB into the housing until it snaps into place.

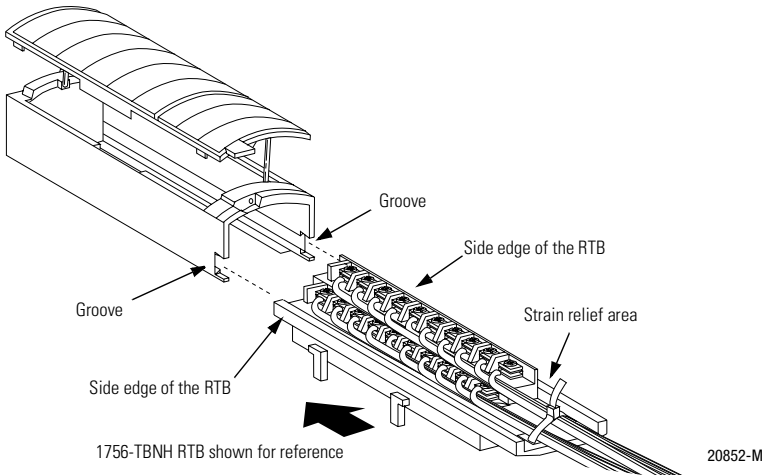

Install the Removable Terminal Block onto the Module

ATTENTION



Shock hazard exists. If the RTB is installed onto the module while the field-side power is applied, the RTB will be electrically live. Do not touch the RTB's terminals. Failure to observe this caution may cause personal injury.

The RTB is designed to support Removal and Insertion Under Power (RIUP). However, when you remove or insert an RTB with field-side power applied, **unintended machine motion or loss of process control can occur.** Exercise extreme caution when using this feature. It is recommended that field-side power be removed before installing the RTB onto the module.

Before installing the RTB, make certain:

- field-side wiring of the RTB has been completed.
- the RTB housing is snapped into place on the RTB.
- the RTB housing door is closed.
- the locking tab at the top of the module is unlocked.

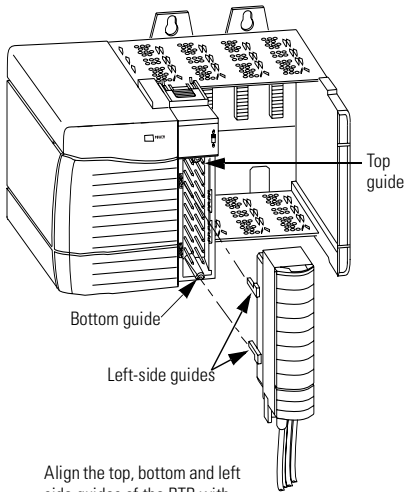

Align the top, bottom and left side guides of the RTB with the guides on the module.

20853-M

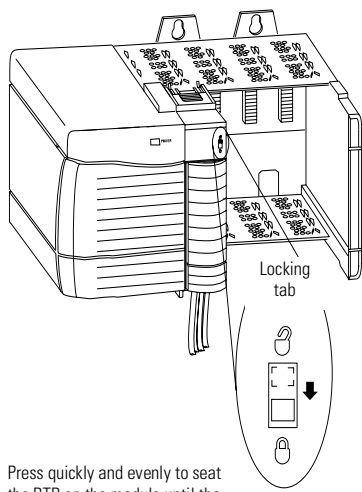

Press quickly and evenly to seat the RTB on the module until the latches snap into place. Slide the locking tab down to lock the RTB onto the module.

20854-M

Check the Indicators

The indicators show individual I/O status (yellow) for each point and a bi-colored LED for module "OK" (red/green).

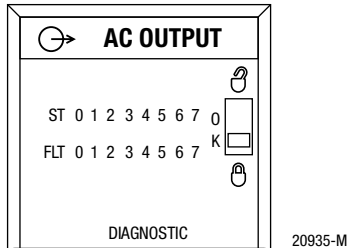

During power up, an indicator test is done. The "OK" indicator turns red for 1 second and then turns to flashing green if it has passed the self-test. The I/O indicators will be active for a maximum of 2 seconds.

LED indicator:	This display:	Means:	Take this action:
OK	Steady green light	The outputs are actively being controlled by a system processor.	None
OK	Flashing green light	The module has passed internal diagnostics but is not actively controlled.	None
OK	Flashing red light	Previously established communication has timed out.	Check controller and chassis communication.
OK	Steady red light	The module must be replaced.	Replace the module.
I/O State	Yellow	The output is active.	None
I/O Fault	Red	A fault has occurred for this point.	Check this point at the controller.

This completes installation of the module. Use the following information to remove the RTB and module.

Remove the Removable Terminal Block from the Module

ATTENTION



Shock hazard exists. If the RTB is removed from the module while the field-side power is applied, the module will be electrically live. Do not touch the RTB's terminals. Failure to observe this caution may cause personal injury.

The RTB is designed to support Removal and Insertion Under Power (RIUP). However, when you remove or insert an RTB with field-side power applied, **unintended machine motion or loss of process control can occur.** Exercise extreme caution when using this feature. It is recommended that field-side power be removed before removing the module.

Before removing the module, you must remove the RTB.

1. Unlock the locking tab at the top of the module.
2. Open the RTB door and pull the RTB off the module as shown below.

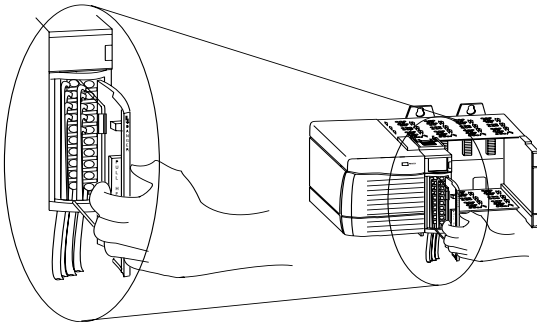

20855-M

Remove the Module

1. Push in top and bottom locking tabs.
2. Pull module out of the chassis.

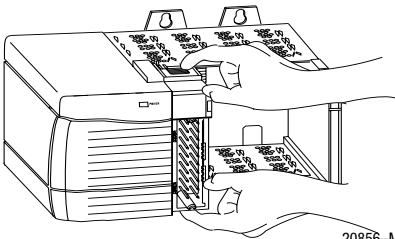



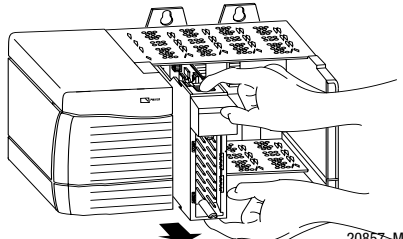

20856-M



20857-M

1756-0A8D Specifications

Number of Outputs	8 (4 points/common)
Module Location	1756 ControlLogix Chassis
Backplane Current	175mA @ 5.1V dc & 250mA @ 24V dc (Total backplane power 6.89W)
Maximum Power Dissipation (Module)	5.3W @ 60°C
Thermal Dissipation	18 BTU/hr
Output Voltage Range	74-132V ac, 47-63Hz
Output Current Rating Per Point Per Module	1A maximum @ 30°C & 0.5A maximum @ 60°C (Linear derating) 8A maximum @ 30°C & 4A maximum @ 60°C (Linear derating)
Surge Current per Point	8A for 43ms each, repeatable every 2s @ 30°C 5A for 43ms each, repeatable every 1s @ 60°C
Minimum Load Current	10mA per point
Maximum On-State Voltage Drop	2.5V peak @ 0.5A & 3V peak @ 1A
Maximum Off-State Leakage Current	3mA per point
Output Delay Time Off to on On to off	9.3ms @ 60Hz; 11ms @ 50Hz 9.3ms @ 60Hz; 11ms @ 50Hz
Diagnostic Functions Short Trip NoLoad Output Verification Pulse Test Field Power Loss (Zero Cross) Time stamp of diagnostics	12A for 500µs minimum Off state detection only On state detection only User selectable maximum width & user selectable maximum time delay from zero cross Detects at 25V peak minimum (Firmware phase locked loop) +/- 1ms
Scheduled Outputs	Synchronization within 16.7s maximum, reference to the Coordinated System Time
Configurable Fault States per Point	Hold Last State, ON or OFF (OFF is the default)
Configurable States in Program Mode per Point	Hold Last State, ON or OFF (OFF is the default)
Maximum Inhibit Voltage	Zero crossing 25V peak
Fusing	Electronically fused per point
Isolation Voltage Group to group User to system	100% tested at 2546V dc for 1s (250V ac maximum continuous voltage between groups) 100% tested at 2546V dc for 1s
Module Keying (Backplane)	Software configurable
RTB Screw Torque (NEMA)	7-9 inch-pounds (0.8-1Nm)
RTB Keying	User defined mechanical keying
RTB and Housing	20 Position RTB (1756-TBNH or TBSH)
Environmental Conditions Operating Temperature Storage Temperature Relative Humidity	0 to 60°C (32 to 140°F) -40 to 85°C (-40 to 185°F) 5 to 95% noncondensing

Conductors	Wire Size	22-14-gauge (2mm ²) stranded ¹
	Category	3/64 inch (1.2mm) insulation maximum 1 ^{2,3}
Screwdriver Width for RTB		5/16 inch (8mm) maximum
User Manual		Publication 1756-6.5.8
Agency Certification (when product or packaging is marked)		  Class I Div 2 Hazardous ⁴  Class I Div 2 Hazardous ⁴  marked for all applicable directives  marked for all applicable acts

- ¹ Maximum wire size will require extended housing - 1756-TBE.
- ² Use this conductor category information for planning conductor routing as described in the system level installation manual.
- ³ Refer to publication 1770-4.1, "Programmable Controller Wiring and Grounding Guidelines"
- ⁴ CSA certification—Class I, Division 2, Group A, B, C, D or nonhazardous locations.
FM approved—Class I, Division 2, Group A, B, C, D or nonhazardous locations.

CSA Hazardous Location Approval

CSA certifies products for general use as well as for use in hazardous locations. Actual CSA certification is indicated by the product label as shown below, and not by statements in any user documentation.

Example of the CSA certification product label:



CL I, DIV 2
GP A,B,C,D
TEMP



To comply with CSA certification for use in hazardous locations, the following information becomes a part of the product literature for this CSA-certified industrial control product::

- This equipment is suitable for use in Class I, Division 2, Groups A, B, C, D, or non-hazardous locations only.
- The products having the appropriate CSA markings (that is, Class I, Division 2, Groups A, B, C, D) are certified for use in other equipment where the suitability of combination (that is, application or use) is determined by the CSA or the local inspection office having jurisdiction.

IMPORTANT

Due to the modular nature of a programmable control system, the product with the highest temperature rating determines the overall temperature code rating of a programmable control system in a Class I, Division 2 location. The temperature code rating is marked on the product label as shown.

Temperature code rating:



CL I, DIV 2
GP A,B,C,D
TEMP



Look for temperature code rating here.

The following warnings apply to products having CSA certification for use in hazardous locations.

ATTENTION



Explosion hazard!

- Substitution of components may impair suitability for Class 1, Division 2.
- Do not replace components unless power has been switched off or the area is known to be non-hazardous.
- Do not disconnect equipment unless power has been switched off or the area is known to be non-hazardous.
- Do not disconnect connectors unless power has been switched off or the area is known to be non-hazardous. Secure any user-supplied connectors that mate to external circuits on this equipment by using screws, sliding latches, threaded connectors, or other means such that any connection can withstand a 15 Newton (3.4 lb) separating force applied for a minimum of one minute.
- If the Product contains batteries, they must only be changed in an area known to be non-hazardous.

CSA logo is a registered trademark of the Canadian Standards Association.

Approbation d'utilisation dans des environnements dangereux par la CSA

La CSA certifie des produits pour une utilisation générale aussi bien que pour une utilisation en environnements dangereux. La certification CSA en vigueur est indiquée par l'étiquette produit et non par des indications dans la documentation utilisateur.

Exemple d'étiquette de certification d'un produit par la CSA:



CL I, DIV 2
GP A,B,C,D
TEMP



Pour satisfaire à la certification CSA en environnements dangereux, les informations suivantes font partie intégrante de la documentation des produits de commande industrielle certifiés.

- Cet équipement ne convient qu'à une utilisation en environnements de Classe 1, Division 2, Groupes A, B, C, D ou non dangereux.
- Les produits portant le marquage CSA approprié (c'est-à-dire Classe 1, Division 2, Groupes A, B, C, D) sont certifiés pour une utilisation avec d'autres équipements, les combinaisons d'applications et d'utilisations étant déterminées par la CSA ou le bureau local d'inspection qualifié.

IMPORTANT

De par la nature modulaire des systèmes de commande programmables, le produit ayant le code de température le plus élevé détermine le code de température global du système dans un environnement de Classe 1, Division 2. Le code de température est indiqué sur l'étiquette produit.

Code de température :



CL I, DIV 2
GP A,B,C,D
TEMP



Le code de température est indiqué ici.

Les avertissements suivants s'appliquent aux produits ayant la certification CSA pour une utilisation en environnements dangereux.

ATTENTION



Risque d'explosion

- La substitution de composants peut rendre cet équipement inadapté à une utilisation en environnements de Classe 1, Division 2.
- Couper le courant ou s'assurer que l'environnement est classé non dangereux avant de remplacer des composants.
- Couper le courant ou s'assurer que l'environnement est classé non dangereux avant de débrancher l'équipement.
- Couper le courant ou s'assurer que l'environnement est classé non dangereux avant de débrancher les connecteurs. Fixer tous les connecteurs fournis par l'utilisateur pour se brancher aux circuits externes de cet équipement à l'aide de vis, loquets coulissants, connecteurs filetés ou autres, de sorte que les connexions résistent à une force de séparation de 15 Newtons (1,5 kg - 3,4 lb.) appliquée pendant au moins une minute.
- S'assurer que l'environnement est classé non dangereux avant de changer les piles.

Le sigle CSA est une marque déposée de l'Association des Standards pour le Canada.

Reach us now at www.rockwellautomation.com

Wherever you need us, Rockwell Automation brings together leading brands in industrial automation including Allen-Bradley controls, Reliance Electric power transmission products, Dodge mechanical power transmission components, and Rockwell Software. Rockwell Automation's unique, flexible approach to helping customers achieve a competitive advantage is supported by thousands of authorized partners, distributors and system integrators around the world.

Americas Headquarters, 1201 South Second Street, Milwaukee, WI 53204, USA, Tel: (1) 414 382-2000, Fax: (1) 414 382-4444
European Headquarters SA/NV, avenue Hermann Dethroux 46, 1180 Brussels, Belgium, Tel: (32) 2 863 06 00, Fax: (32) 2 863 06 40
Asia Pacific Headquarters, 27/F Citicorp Centre, 19 Whitfield Road, Causeway Bay, Hong Kong, Tel: (852) 2887 4788, Fax: (852) 2508 1846



Publication 1756-5.7 - September 1999

Supersedes Publication 1756-5.7 - October 1998

PN 957236-46

© 1999 Rockwell International Corporation. Printed in the U.S.A.