



# ControlLogix Power Supplies

(Catalog Numbers 1756-PA75/A, -PB75/A)

Use this publication as a guide when installing the ControlLogix™ 1756-PA75/PB75 power supplies. These supplies may only be used with Series B chassis.

To install the power supply, read:	See page:
Prepare for Installation	3
Install the Power Supply	3
Connect Equipment Protective Earth Ground	5
Connect Power	7
Remove the Protective Label	8
Activate the Power Supply	8

For this reference information:	See page:
Compliance to European Union Directives	2
Troubleshooting	9
CSA Hazardous Location Approval	9
1756-PA75/A, -PB75/A Specifications	12

### ATTENTION



Electrostatic discharge can damage integrated circuits or semiconductors if you touch backplane connector pins. Follow these guidelines when you handle the 1756-PA75/A or 1756-PB75/A.

- Touch a grounded object to discharge static potential.
- Do not touch the backplane connector or connector pins.
- Do not touch circuit components inside the power supply.
- If available, use a static-safe work station.
- When not in use, keep the power supply in its static-shield packaging.

## Compliance to European Union Directives

If this product bears the CE marking it is approved for installation within the European Union and EEA regions. It has been designed and tested to meet the following directives.

### EMC Directive

This apparatus is tested to meet Council Directive 89/336/EEC Electromagnetic Compatibility (EMC) using a technical construction file and the following standards, in whole or in part:

- EN 50081-2 EMC - Generic Emission Standard, Part 2 - Industrial Environment
- EN 50082-2 EMC - Generic Immunity Standard, Part 2 - Industrial Environment

The product described in this document is intended for use in an industrial environment.

### Low Voltage Directive

This product is also designed to meet Council Directive 73/23/EEC Low Voltage, by applying the safety requirements of EN 61131-2 Programmable Controllers, Part 2 - Equipment Requirements and Tests.

For specific information required by EN 61131-2, see the appropriate sections in this publication, as well as the following Allen-Bradley publications:

- *Industrial Automation Wiring and Grounding Guidelines*, publication 1770-4.1
- *Automation Systems Catalog*, publication B111

This equipment is classified as open equipment and must be installed (mounted) in an enclosure during operation as a means of providing safety protection.

## Prepare for Installation

### Power Supply

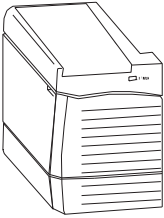

### These Tools

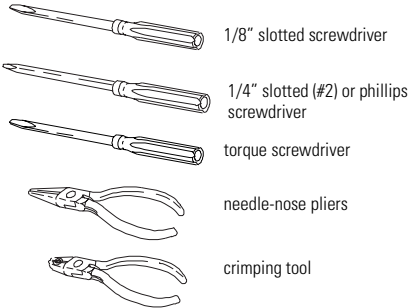

20181-M

## Install the Power Supply

1. Verify that the voltage jumper is present and in the factory-preset position:

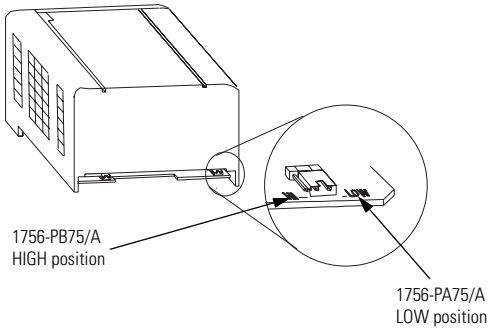

44143

2. Align the circuit board of the power supply with the card guides on the left side of the Series B chassis.

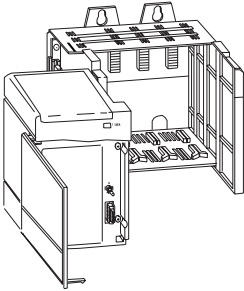

20264a-M

3. Guide the extended tab on the power supply circuit board into the notch of the Series B chassis. Slide the power supply in until it is flush with the back of the chassis.

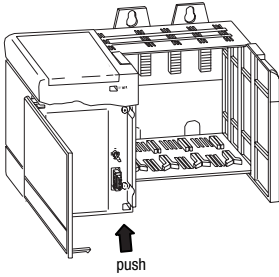

44144

4. Fasten the power supply to the chassis.

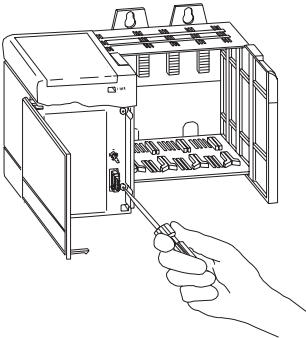

44145

## Connect Equipment Protective Earth Ground

Use the following figure to connect equipment protective earth ground from the power supply to the chassis.

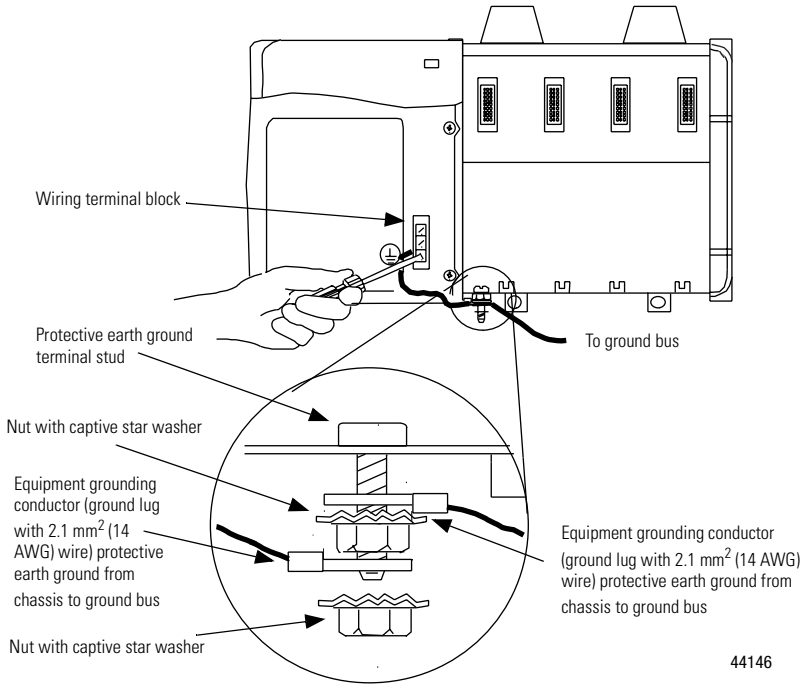
**IMPORTANT**

Tighten the nut on the equipment protective earth ground terminal stud to a torque of 12 inch-pounds.

## Verify Grounding Configuration

This figure shows you how to run functional and equipment protective earth ground connections from the chassis. Using a ground bus is recommended because it reduces the electrical resistance at the connection.



For more information on installing and connecting protective earth ground to the ControlLogix chassis, refer to the ControlLogix Chassis Installation Instructions, publication 1756-5.2.

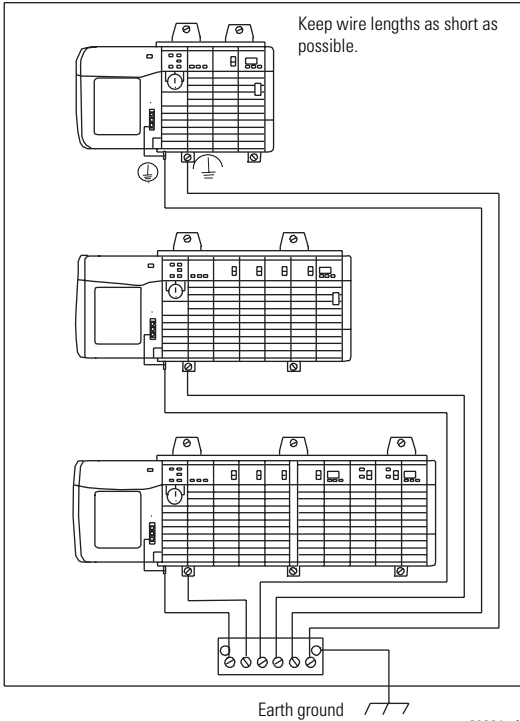

## Connect Power

### ATTENTION



Turn off power lines before connecting power; failure to do so could cause injury to personnel and/or equipment. This equipment must be provided with a disconnect on each ungrounded conductor.

### TIP



For this connection, use #14 AWG 75°C copper wire.

Tighten the terminals to a torque of 7 inch-pounds (0.79 Newton-meters).

### 1756-PA75/A

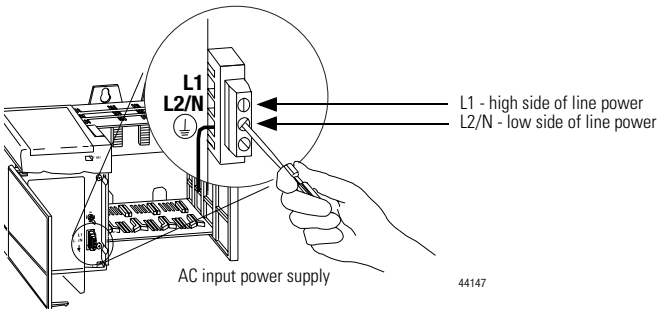

### 1756-PB75/A

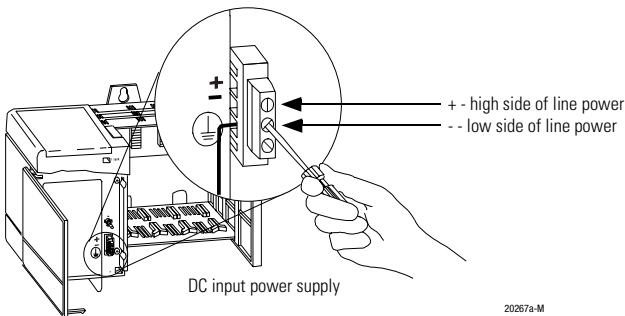

## Remove the Protective Label

**ATTENTION**



Make sure the chassis is mounted and all panel fabrication is complete before you remove the protective label. This label protects the power supply from metal shavings falling inside the power supply and damaging it during operation.

---

Remove the plastic label from the top of the power supply.

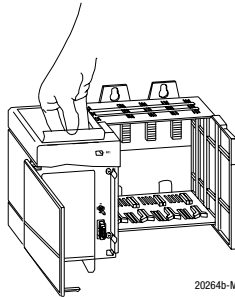

## Activate the Power Supply

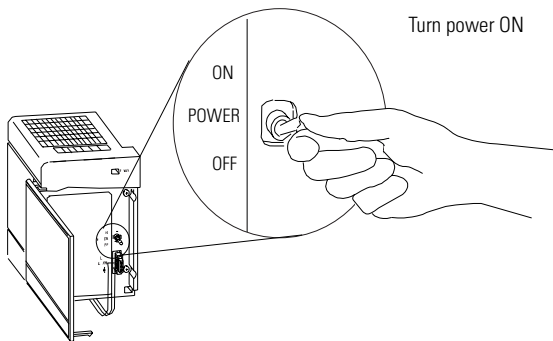



## Troubleshooting

The ControlLogix power supplies have a green LED indicator that remains ON during normal operation.

### Indicator

### If indicator is off

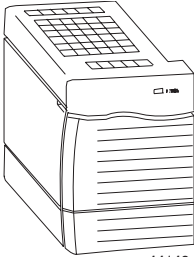

44148

1. Verify that the line voltage is within the specified range.
2. If indicator remains off, cycle line power OFF.
3. Loosen the screws holding the power supply to the chassis.
4. Slide the power supply out so that the rear connector is disconnected.
5. Make sure the voltage jumper is present and in the factory-preset settings: 1756-PA75/A- low position, 1756-PB75/A - high position.
6. Wait 45 seconds and reapply input power.
7. If the indicator turns on, verify that the module loads in the system are within the output rating of the power supply and reinstall the power supply in the chassis. If the LED remains off, return the power supply to your local Allen-Bradley distributor.

## CSA Hazardous Location Approval

CSA certifies products for general use as well as for use in hazardous locations. Actual CSA certification is indicated by the product label as shown below, and not by statements in any user documentation.



CL I, DIV 2  
GP A,B,C,D  
TEMP

Example of the CSA certification product label



To comply with CSA certification for use in hazardous locations, the following information becomes a part of the product literature for this CSA-certified industrial control product:

- This equipment is suitable for use in Class I, Division 2, Groups A, B, C, D, or non-hazardous locations only.
- The products having the appropriate CSA markings (that is, Class I, Division 2, Groups A, B, C, D) are certified for use in other equipment where the suitability of combination (that is, application or use) is determined by the CSA or the local inspection office having jurisdiction.

### IMPORTANT

Due to the modular nature of a programmable control system, the product with the highest temperature rating determines the overall temperature code rating of a programmable control system in a Class I, Division 2 location. The temperature code rating is marked on the product label as shown.



CL I, DIV 2  
GP A,B,C,D  
TEMP



Look for temperature code rating here.

The following warnings apply to products having CSA certification for use in hazardous locations.

**ATTENTION**



Explosion hazard!

- Substitution of components may impair suitability for Class I, Division 2.
- Do not replace components unless power has been switched off or the area is known to be non-hazardous.
- Do not disconnect equipment unless power has been switched off or the area is known to be non-hazardous.
- Do not disconnect connectors unless power has been switched off or the area is known to be non-hazardous. Secure any user-supplied connectors that mate to external circuits on this equipment by using screws, sliding latches, threaded connectors, or other means such that any connection can withstand a 15 Newton (3.4 lb) separating force applied for a minimum of one minute.
- If the product contains batteries, they must only be changed in an area known to be non-hazardous.

CSA logo is a registered trademark of the Canadian Standards Association.

## Approbation d'utilisation dans des environnements dangereux par la CSA

La CSA certifie des produits pour une utilisation générale aussi bien que pour une utilisation en environnements dangereux. La certification CSA en vigueur est indiquée par l'étiquette produit et non par des indications dans la documentation utilisateur.



CL I, DIV 2  
GP A,B,C,D  
TEMP

Exemple d'étiquette de certification d'un produit par la CSA



Pour satisfaire à la certification CSA en environnements dangereux, les informations suivantes font partie intégrante de la documentation des produits de commande industrielle certifiés:

- Cet équipement ne convient qu'à une utilisation dans des environnements de Classe 1, Division 2, Groupes A, B, C, D, ou non dangereux.
- Les produits portant le marquage CSA approprié (c'est-à-dire Classe 1, Division 2, Groupes A, B, C, D) sont certifiés pour une utilisation avec d'autres équipements, les combinaisons d'applications et d'utilisation étant déterminées par la CSA ou le bureau local d'inspection.

**IMPORTANT**

De par la nature modulaire des systèmes de commande programmables, le produit ayant le code de température le plus élevé détermine le code de température global du système dans un environnement de Classe I, Division 2. Le code de température est indiqué sur l'étiquette produit.



CL I, DIV 2  
GP A,B,C,D  
TEMP



Le code de température est indiqué ici.

Les avertissements suivants s'appliquent aux produits ayant la certification CSA pour une utilisation dans des environnements dangereux.





**ATTENTION**

Risque d'explosion --

- La substitution de composants peut rendre ce matériel inadapté à une utilisation en environnement de Classe 1, Division 2.
- Couper le courant ou s'assurer que l'environnement est classé non dangereux avant de remplacer des composants.
- Couper le courant ou s'assurer que l'environnement est classé non dangereux avant de débrancher l'équipement.
- Couper le courant ou s'assurer que l'environnement est classé non dangereux avant de débrancher les connecteurs. Fixer tous les connecteurs fournis par l'utilisateur pour se brancher aux circuits externes de cet appareil à l'aide de vis, loquets coulissants, connecteurs filetés ou autres, de sorte que les connexions résistent à une force de séparation de 15 Newtons (1.5 kg - 3.4 lb.) appliquée pendant au moins une minute.
- S'assurer que l'environnement est classé non dangereux avant de changer les piles.

AVERTISSEMENT :Le sigle CSA est une marque déposée de la Canadian Standards Association.

# 1756-PA75/A, -PB75/A Specifications

	<b>1756-PA75/A</b>	<b>1756-PB75/A</b>
<i>Input Voltage Range</i>	85-265 V ac	19.2-32 V dc (16-32V dc) <sup>1</sup>
<i>Input Power</i>	225 VA, 95 W	95 W
<i>Output Power</i>	CSA certified – 75W @ 60°C FM approved – 75W @ 60°C UL listed – 75W @ 60°C	
<i>Hold Up Time<sup>2</sup></i> <i>(typical)</i>	@ 60 Hz: 85 V ac: 2 cycles 120 V ac: 6 cycles 200 V ac: 20 cycles	19 V dc: 20 mS 24 V dc: 70 mS
<i>Maximum Inrush Current</i>	20 A	30 A
<i>Frequency Range</i>	47-63 Hz	dc
<i>Backplane Output Current — maximum<sup>3</sup></i>	1.5 A @ 1.2 V 4 A @ 3.3 V 13 A @ 5.1 V 2.8 A @ 24 V	
<i>Maximum user-supplied overcurrent protection<sup>4</sup></i>	15 A	15 A
<i>Internal Fuse Protection<sup>5</sup></i>	non-replaceable fuse is soldered in place	
<i>Wiring</i>	#14 AWG 75°C copper	
<i>Connector Screw Torque</i>	7 inch-pounds (0.79 Newton-meters)	
<i>Dimensions (W x H x D)</i>	11.2 x 14.0 x 14.5 cm (4.41 x 5.51 x 5.71")	
<i>Weight — approximate</i>	1.1 kg (2.5 lbs)	
<i>Location</i>	left side of Series B chassis only	
<i>Environmental Operating Temperature Conditions</i>	0 to 60°C	
<i>Storage Temperature</i>	-40 to 85°C (-40 to 185°F)	
<i>Relative Humidity</i>	5 to 95%, noncondensing	
<i>Agency Certification</i> <i>(when product or packaging is marked)</i>	  Class I Div 2 Hazardous <sup>6</sup>  Class I Div 2 Hazardous <sup>6</sup>  marked for all applicable directives  marked for all applicable acts <b>N223</b>	

1 Input may drop to 16 V for a maximum of two minutes each hour for motor starting.

2 Time between input voltage removal and dc power failure.

3 The combination of all output power (5.1 V backplane, 24 V backplane, 3.3 V backplane, and 1.2 V backplane) cannot exceed 75 W.

4 Use time-delay type overcurrent protection in all ungrounded conductors.

5 This fuse is intended to guard against fire hazard due to short circuit conditions.

6 CSA certification - Class I, Division 2, Group A, B, C, D, or nonhazardous locations.

FM approved - Class I, Division 2, Group A, B, C, D, or nonhazardous locations.

## Reach us now at [www.rockwellautomation.com](http://www.rockwellautomation.com)

Wherever you need us, Rockwell Automation brings together leading brands in industrial automation including Allen-Bradley controls, Reliance Electric power transmission products, Dodge mechanical power transmission components, and Rockwell Software, Rockwell Automation's unique, flexible approach to helping customers achieve a competitive advantage is supported by thousands of authorized partners, distributors and system integrators around the world.

**Americas Headquarters**, 1201 South Second Street, Milwaukee, WI 53204, USA, Tel: (1) 414 382-2000, Fax: (1) 414 382-4444  
**European Headquarters SA/AV**, avenue Herrmann Debroux, 46, 1180 Brussels, Belgium, Tel: (32) 2 663 06 00, Fax: (32) 2 663 06 40  
**Asia Pacific Headquarters**, 27/F Citicorp Centre, 18 Whitfield Road, Causeway Bay, Hong Kong, Tel: (852) 2887 4788, Fax: (852) 2508 1846



**Rockwell Automation**

Publication 1756-5.78 - September 1999

Supersedes Publication 1756-5.67 - July 1998

PN 957208-25

© 1999 Rockwell International Corporation. Printed in the U.S.A.