



## ControlLogix Chassis—Series B

(Catalog Numbers 1756-A4, -A7, -A10, -A13, -A17)

Use this publication as a guide when installing a ControlLogix™ chassis.

To install the chassis, read:	See page:
Prepare for Installation	this page
Allow Sufficient Mounting Space	3
Install Your Chassis	4
Ground Your Chassis	6
Attach Your Power Supply and Install Your Modules	9

For this reference information	See page
Compliance to European Union Directives	2
Mounting Dimensions	10
Specifications	12
CSA Hazardous Location Approval	13

## Prepare for Installation

Make sure you have these items.

- M4 or M5 (#10 or #12) mounting tab screws and washers
- drill
- documentation for your ControlLogix modules that will be placed in the chassis
- phillips screwdriver

For each	You need
top mounting tab	1 phillips screw, 1 flat washer, 1 split lock-washer
bottom mounting tab	1 phillips screw and 1 star washer or 1 SEM screw <sup>1</sup>

<sup>1</sup> Phillips screw with attached star washer

This chassis	Number of mounting tabs	
1756-A4, -A7	2 top	2 bottom
1756-A10	3 top	3 bottom
1756-A13	4 top	4 bottom
1756-A17	5 top	5 bottom

**ATTENTION**



Electrostatic discharge can damage integrated circuits or semiconductors if you touch backplane connector pins. Follow these guidelines when you handle the 1756-PA72/B, 1756-PB72/B, 1756-PA75/A, or 1756-PB75/A.

- Touch a grounded object to discharge static potential.
  - Do not touch the backplane connector or connector pins.
  - Do not touch circuit components inside the power supply.
  - If available, use a static-safe work station.
  - When not in use, keep the power supply in its static-shield packaging.
- 

## Compliance to European Union Directives

If this product bears the CE marking, it is approved for installation within the European Union and EEA regions. It has been designed and tested to meet the following directives.

### EMC Directive

This apparatus is tested to meet Council Directive 90/336/EEC Electromagnetic Compatibility (EMC) using a technical construction file and the following standards, in whole or in part:

- EN 50081-2 EMC - Generic Emission Standard, Part 2 - Industrial Environment
- EN 50082-2 EMC - Generic Immunity Standard, Part 2 - Industrial Environment

The product described in this document is intended for use in an industrial environment.

### Low Voltage Directive

This product is also designed to meet Council Directive 73/23/EEC Low Voltage, by applying the safety requirements of EN 61131-2 Programmable Controllers, Part 2 - Equipment Requirements and Tests.

For specific information required by EN 61131-2, see the appropriate sections in this publication, as well as the following Allen-Bradley publications:

- *Industrial Automation Wiring and Grounding Guidelines*, publication 1770-4.1
- *Automation Systems Catalog*, publication B111

This equipment is classified as open equipment and must be installed (mounted) in an enclosure during operation as a means of providing safety protection.

### Allow Sufficient Mounting Space

**IMPORTANT**

Make sure you meet these **minimum** spacing requirements.

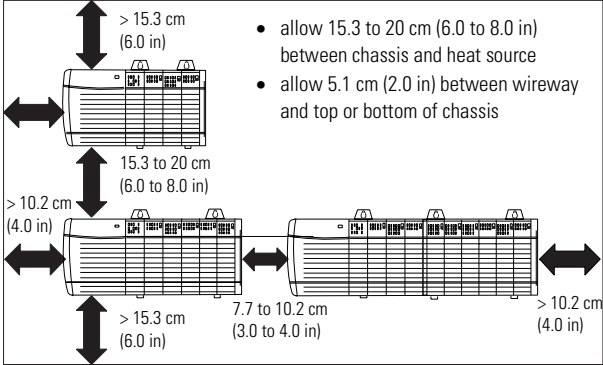

20230a-M

## Minimum Cabinet Size

### IMPORTANT

To meet the UL/CSA standards, do not exceed these **minimum** cabinet size requirements.

Chassis	Minimum Cabinet Size (W x H x D)
1756-A4	50.7 x 50.7 x 20.3 cm 20 x 20 x 8 in
1756-A7	50.7 x 70 x 20.3 cm 20 x 24 x 8 in
1756-A10	76.2 x 50.7 x 20.3 cm 30 x 20 x 8 in
1756-A13	76.2 x 70 x 20.3 cm 30 x 24 x 8 in
1756-A17	82.2 x 76.2 x 20.3 cm 36 x 30 x 8 in

## Install Your Chassis

### ATTENTION



Do not drill holes for a chassis above an installed chassis. Metal chips from drilling can damage the backplane and cause intermittent operation.

1. Drill holes in the back panel of the enclosure for chassis mounting tabs. See *Mounting Dimensions*, on page 10, for assistance in hole placement.

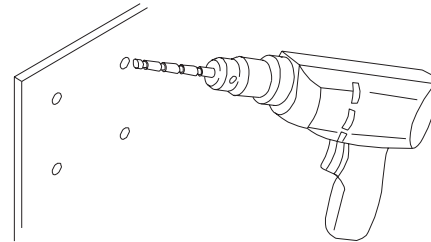

20288

2. Install the hardware for the top mounting tabs.

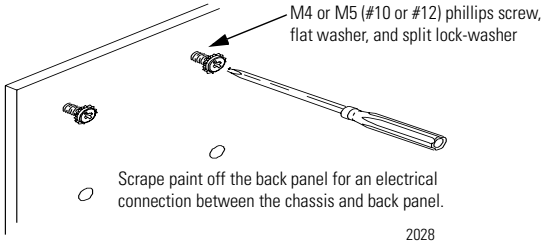

3. Slide the chassis over the installed screws and tighten them.

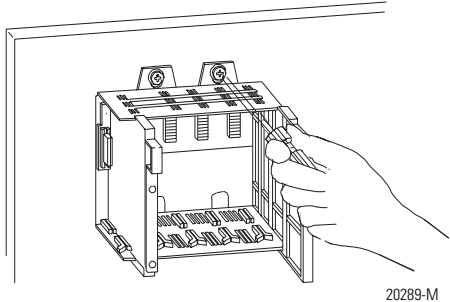

**ATTENTION**



If the chassis mounting tabs do not lay flat before the screws are tightened, use additional washers as shims so the chassis is not warped by tightening the screws.

Warping a chassis could damage the backplane and cause intermittent operation.

4. Leaving the far-left bottom tab open for functional ground, install the remaining tab screw(s).

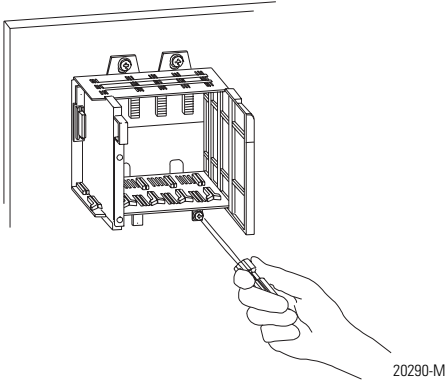

## Ground Your Chassis

<b>To properly ground your I/O chassis, read:</b>	<b>See page:</b>
Verify Grounding Configuration	this page
Install a Central Ground Bus	7
Connect Functional Ground	7
Connect Equipment Protective Earth Ground	8
Connect Equipment Grounding Conductor to Ground Bus	8
Connect Ground Bus to Grounding-Electrode System	9

### Verify Grounding Configuration

This figure shows you how to run functional and equipment protective earth ground connections from the chassis and power supply to the ground bus. Using a ground bus is recommended because it reduces the electrical resistance at the connection.



For more information on installing and connecting protective earth ground to the ControllLogix power supply, refer to the ControllLogix Power Supplies Installation Instructions, publication 1756-5.1.

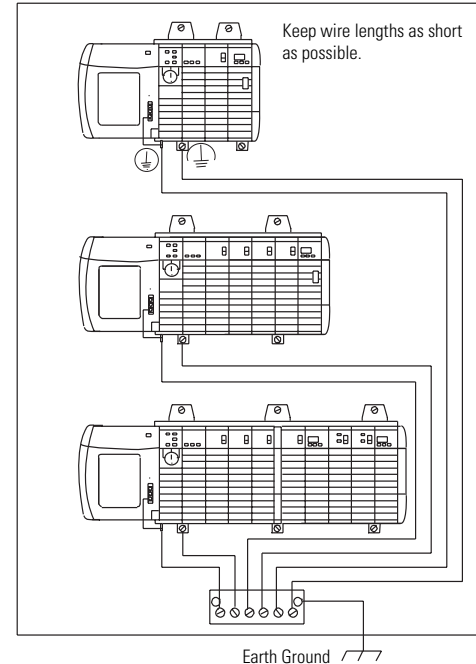

20231a-M

### Install a Central Ground Bus

Each enclosure must contain a central ground bus. The ground bus is the common connection for each chassis within the enclosure and the enclosure itself.



For more information on installing a central ground bus, refer to the Industrial Automation Wiring and Grounding Guidelines, publication 1770-4.1

### Connect Functional Ground

Use the following figure to connect functional ground to the chassis.

### Functional Ground Connection

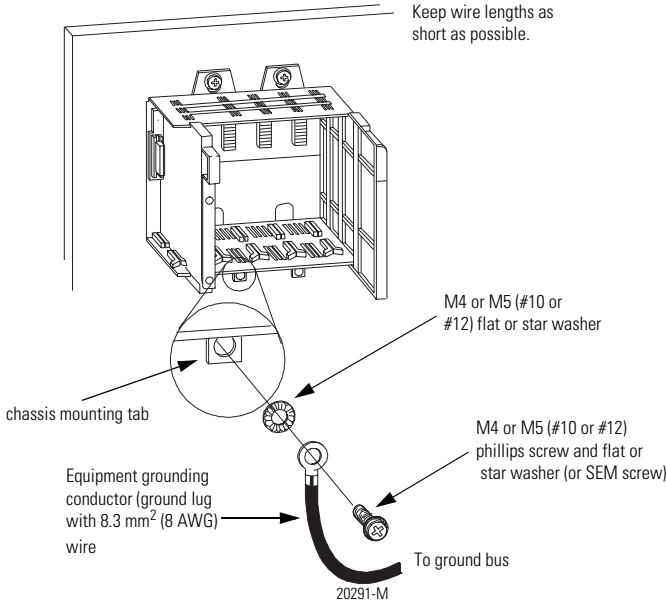

## Connect Equipment Protective Earth Ground

Use the following figure to connect equipment protective earth ground to the chassis.

### IMPORTANT

Tighten the nut on the equipment protective earth ground terminal stud to a torque of 12 inch-pounds.

### Equipment Protective Earth Ground Connection

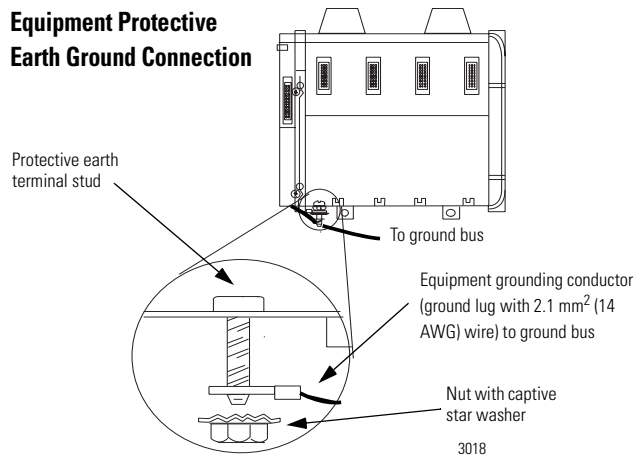

## Connect the Equipment Grounding Conductors to the Ground Bus

Connect the equipment grounding conductors (functional and equipment protective earth ground) directly from each chassis to an individual bolt on the ground bus.

### IMPORTANT

Do not lay one ground lug directly on top of the other; this connection can become loose due to compression of the metal lugs. Place the first lug between a star washer and a nut with a captive star washer. After tightening the nut, place the second lug between the first nut and a second nut with a lug between the first nut and a second nut with a captive star washer.



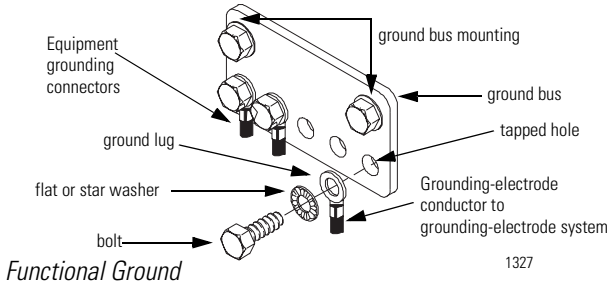

- use 2.54 cm (1 in) thick copper braid or 8.3 mm<sup>2</sup> (8 AWG) copper wire to connect equipment grounding conductor for each chassis, the enclosure, and a central ground bus mounted on the back-panel
- use a steel enclosure to guard against electromagnetic interference (EMI)
- make sure the enclosure door viewing window is a laminated screen or a conductive optical substrate (to block EMI)

*Equipment Protective Earth Ground*

- use a 2.1 mm<sup>2</sup> (14 AWG) copper wire for the equipment grounding conductors
- install a bonding wire for electrical contact between the door and the enclosure; do not rely on the hinge.

**Connect Ground Bus to Grounding-Electrode System**

The grounding-electrode system is at earth-ground potential and is the central ground for all electrical equipment and ac power within any facility. Use a grounding-electrode conductor to connect the ground bus to the grounding-electrode system.

Use at minimum 8.3 mm<sup>2</sup> (8 AWG) copper wire for the grounding-electrode conductor to guard against EMI. The National Electrical Code specifies safety requirements for the grounding-electrode conductor.

**Attach Your Power Supply and Install Your Modules**

Use the installation instructions/user manuals for your modules to install them in the chassis.

Use the installation instructions for your power supply (document #1756-5.78) to attach it to your chassis.

## Mounting Dimensions

For dimensions of:	See page:
right side of all chassis	this page
1756-A4, -A7	this page
1756-A10, -A13, -A17	11

Right-side view of all chassis

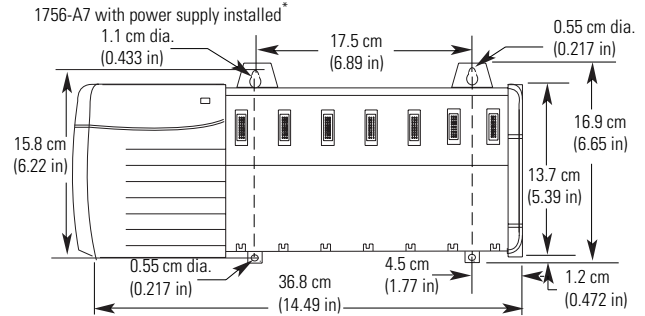
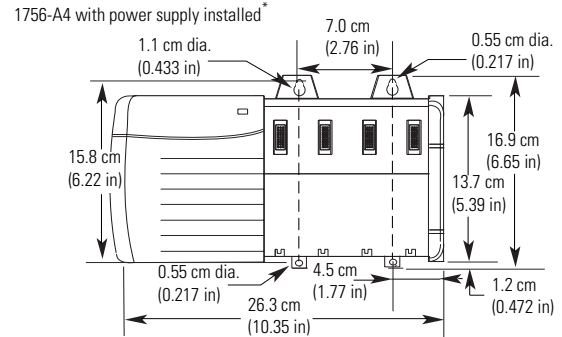
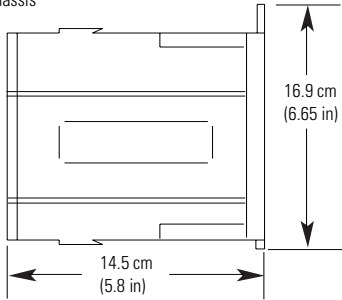



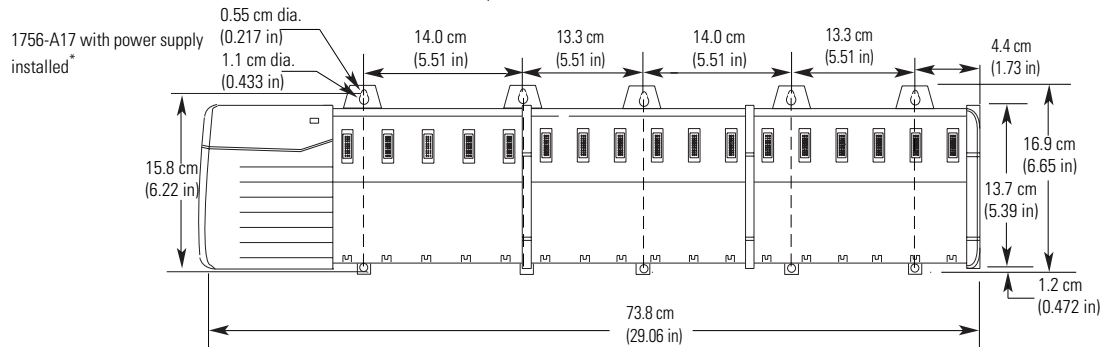
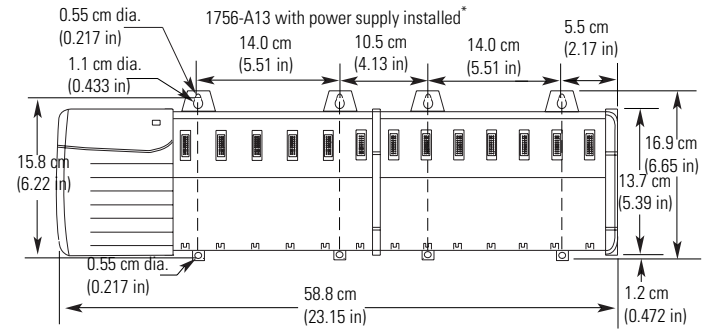
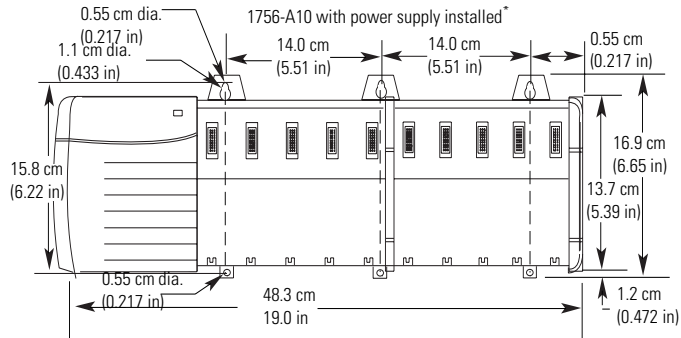

\* The Series B chassis is compatible with 1756-PA72, -PB72, and 1756-PA75, -PB75



\* The Series B chassis is compatible with 1756-PA72, -PB72, and 1756-PA75, -PB75

## Specifications

	1756-A4	1756-A7	1756-A10	1756-A13	1756-A17
<i>dimensions (with tabs) W x H x D</i>	17.7 x 16.9 x 14.5 cm (7.71 x 6.65 x 5.8 in)	28.2 x 16.9 x 14.5 cm (11.3 x 6.65 x 5.8 in)	39.7 x 16.9 x 14.5 cm (15.9 x 6.65 x 5.8 in)	50.2 x 16.9 x 14.5 cm (19.7 x 6.65 x 5.8 in)	65.2 x 16.9 x 14.5 cm (25.7 x 6.65 x 5.8 in)
<i>minimum cabinet size W x H x D</i>	50.7 x 50.7 x 20.3 cm (20 x 20 x 8 in)	50.7 x 70 x 20.3 cm (20 x 24 x 8 in)	76.2 x 50.7 x 20.3 cm (30 x 20 x 8 in)	76.2 x 70 x 20.3 cm (30 x 24 x 8 in)	82.2 x 76.2 x 20.3 cm (36 x 30 x 8 in)
<i>approximate weight (without modules)</i>	0.75 kg (1.7 lbs)	1.1 kg (2.4 lbs)	1.45 kg (3.2 lbs)	1.9 kg (4.2 lbs)	2.2 kg (4.8 lbs)
<i>module slots</i>	4	7	10	13	17
	<b>chassis/slot</b>				
<i>maximum backplane current</i>	5.1 V dc 24 V dc 3.3 V dc	15 A/6 A 2.8 A/2.8 A 4 A/4 A			
<i>type of mount</i>	panel mount				
<i>operating conditions</i>	operating temperature: 0° to 60° C (32° to 140° F) storage temperature: -40° to 85° C (-40° to 185° F) relative humidity: 5 to 95% (without condensation)				
<i>agency certification (when product or packaging is marked)</i>		 Class I, Division 2 hazardous <sup>1</sup>	 FM APPR VEE	 N223	marked for all applicable acts
	 marked for all applicable directives				

<sup>1</sup> CSA certification - Class I, Division 2, Group A, B, C, D, or nonhazardous locations

## CSA Hazardous Location Approval

CSA certifies products for general use as well as for use in hazardous locations. Actual CSA certification is indicated by the product label as shown below, and not by statements in any user documentation.

Example of the CSA certification product label:



To comply with CSA certification for use in hazardous locations, the following information becomes a part of the product literature for this CSA-certified industrial control product.

- This equipment is suitable for use in Class I, Division 2, Groups A, B, C, D, or non-hazardous locations only.
- The products having the appropriate CSA markings (that is, Class I, Division 2, Groups A, B, C, D) are certified for use in other equipment where the suitability of combination (that is, application or use) is determined by the CSA or the local inspection office having jurisdiction.

### IMPORTANT

Due to the modular nature of a programmable control system, the product with the highest temperature rating determines the overall temperature code rating of a programmable control system in a Class I, Division 2 location. The temperature code rating is marked on the product label as shown.

### Temperature Code Rating

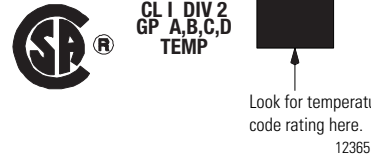

The following warnings apply to products having CSA certification for use in hazardous locations.

**ATTENTION**



Explosion hazard!

- Substitution of components may impair suitability for Class I, Division 2.
- Do not replace components unless power has been switched off or the area is known to be non-hazardous.
- Do not disconnect equipment unless power has been switched off or the area is known to be non-hazardous.
- Do not disconnect connectors unless power has been switched off or the area is known to be non-hazardous. Secure any user-supplied connectors that mate to external circuits on this equipment by using screws, sliding latches, threaded connectors, or other means such that any connection can withstand a 15 Newton (3.4 lb) separating force applied for a minimum of one minute.
- If the product contains batteries, they must only be changed in an area known to be non-hazardous.

CSA logo is a registered trademark of the Canadian Standards Association.

## Approbation d'utilisation dans des environnements dangereux par la CSA

La CSA certifie des produits pour une utilisation générale aussi bien que pour une utilisation en environnements dangereux. La certification CSA en vigueur est indiquée par l'étiquette produit et non par des indications dans la documentation utilisateur.

Exemple d'étiquette de certification d'un produit par la CSA:



Pour satisfaire à la certification CSA en environnements dangereux, les informations suivantes font partie intégrante de la documentation des produits de commande industrielle certifiés.

- Cet équipement ne convient qu'à une utilisation dans des environnements de Classe I, Division 2, Groupes A, B, C, D, ou non dangereux.
- Les produits portant le marquage CSA approprié (c'est-à-dire Classe I, Division 2, Groupes A, B, C, D) sont certifiés pour une utilisation avec d'autres équipements, le combinaison d'applications et d'utilisation étant déterminées par la CSA ou le bureau local d'inspection.

**IMPORTANT**

De par la nature modulaire des systèmes de commande programmables, le produit ayant le code de température le plus élevé détermine le code de température global du système dans un environnement de Classe I, Division 2. Le code de température est indiqué sur l'étiquette produit.



CL I DIV 2  
GP A,B,C,D  
TEMP



Le code de température est  
indiqué ici.

12365

Les avertissements suivants s'appliquent aux produits ayant la certification CSA pour une utilisation dans des environnements dangereux.

**ATTENTION**

Risque d'explosion!

- La substitution de composants peut rendre ce matériel inadapté à une utilisation en environnement de Classe I, Division 2.
- Couper le courant ou s'assurer que l'environnement est classé non dangereux avant de remplacer des composants.
- Couper le courant ou s'assurer que l'environnement est classé non dangereux avant de débrancher les connecteurs. Fixer tous les connecteurs fournis par l'utilisateur pour se brancher aux circuits externes de cet appareil à l'aide de vis, loquets coulissants, connecteurs filetés ou autres, de sorte que les connexions résistent à une force de séparation de 15 Newtons (1.5 kg - 3.4 lb) appliquée pendant au moins une minute.
- S'assurer que l'environnement est classé non dangereux avant de changer les piles.

AVERTISSEMENT: Le sigle CSA est une marque déposée de la Canadian Standards Association.

Allen-Bradley, ControlLogix, and PLC are trademarks of Rockwell Automation. CSA logo is a registered trademark of the Canadian Standards Association.

Le sigle CSA est la marque déposée de l'Association des Standards pour le Canada. Allen-Bradley, ControlLogix, et PLC sont des marques déposées de Allen-Bradley Company, Inc.

---

## Reach us now at [www.rockwellautomation.com](http://www.rockwellautomation.com)

Wherever you need us, Rockwell Automation brings together leading brands in industrial automation including Allen-Bradley controls, Reliance Electric power transmission products, Dodge mechanical power transmission components, and Rockwell Software. Rockwell Automation's unique, flexible approach to helping customers achieve a competitive advantage is supported by thousands of authorized partners, distributors and system integrators around the world.

**Americas Headquarters**, 1201 South Second Street, Milwaukee, WI 53204, USA, Tel: (1) 414 382-2000, Fax: (1) 414 382-4444

**European Headquarters SA/NV**, avenue Hermann Debroux, 46, 1160 Brussels, Belgium, Tel: (32) 2 663 06 00, Fax: (32) 2 663 06 40

**Asia Pacific Headquarters**, 27/F Citicorp Centre, 18 Whitfield Road, Causeway Bay, Hong Kong, Tel: (852) 2887 4788, Fax: (852) 2508 1846

Publication 1756-5.80 - September 1999



**Rockwell  
Automation**

PN 957208-86

© 1999 Rockwell International Corporation. Printed in the U.S.A.