



# Data Highway/Data Highway Plus Asynchronous Communication Interface Module, Series D

Catalog Number 1770-KF2

Use these release notes with the Data Highway or Data Highway Plus Asynchronous (RS-232-C or RS-422-A) Interface Module User Manual, publication 1770-6.5.13, March 1989.

These release notes supersede all previous documentation updates and release notes.

## Updates to the Series D

Updates to the 1770-KF2 module for Series D include the removal of UL and CSA certifications.

## Applicable Standards and Certifications

The 1770-KF2 module conforms to:

- FCC Part 15, Subpart J, Class A
- DOC R.I.R. SEP, 1988
- CE

---

**ATTENTION**

Due to the removal of UL/CSA certifications, the Series D 1770-KF2 is intended to serve as a replacement for previously installed 1770-KF2 modules. For new DH+ installations that require UL/CSA, the 1785-KE would be a more appropriate substitute.

---

**WARNING**

With any complex communication system you need to identify potential application-related communication problems and make provisions in the system design to prevent hazardous or undesired consequences, if a problem occurs. These problems include, but are not limited to, the possibility of unexpected loss of communication, and erroneous or incomplete data being supplied to the network and passed on to your application.

---

# Allen-Bradley PLCs

## Cabling

Series D includes additional circuit protection on the computer (asynchronous) connector, and lower power consumption. To get the full benefit of the additional circuit protection, your RS-232-C cable must conform to these requirements:

- signal ground (pin 7) must be isolated from protective ground (pin 1)
- the cable shield must be connected to protective ground (pin 1) at only one end of the cable; leave the other end unconnected

### IMPORTANT

Cables using protected ground (pin 1) rather than signal ground (pin 7) may have worked with earlier revisions of the 1770-KF2 module, but will not work reliably with Series D.

The standard 25-pin RS-232-C cable connections shown on the configuration label indicate the minimum cabling requirements for RS-232-C communication between the 1770-KF2 module and a computer. They are an alternative to the connections shown in Figure 3.6b of the user manual, reproduced here as Figure 1.

**Figure 1 Wiring Diagram for RS-232-C Cable**

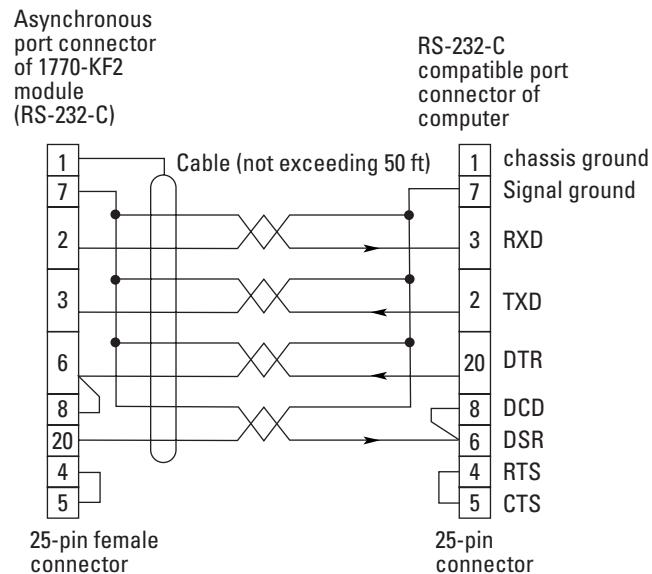

31486-M

If you have constructed or purchased a cable that meets the standards in Figure 1 or that matches the standard 25-pin RS-232-C cable connections on the configuration label, no changes in cabling are required. If your cable does not conform to these specifications, it might communicate correctly, but the effect of the improvements in the Series D hardware will be minimized.

An RS-232-C cable conforming to the pinouts shown in Figure 1, but without the twisted pairs, is supplied with the 1770-KF2 module.

## Connecting the Module to a Data Highway or Data Highway Plus Network

To make twinaxial cable connections to the 1770-KF2 module, connect the 1770-CD cable to the 15-pin connector labeled Data Highway (Figure 2).

**Figure 2 Connecting the Module to a Data Highway or Data Highway Plus Network**

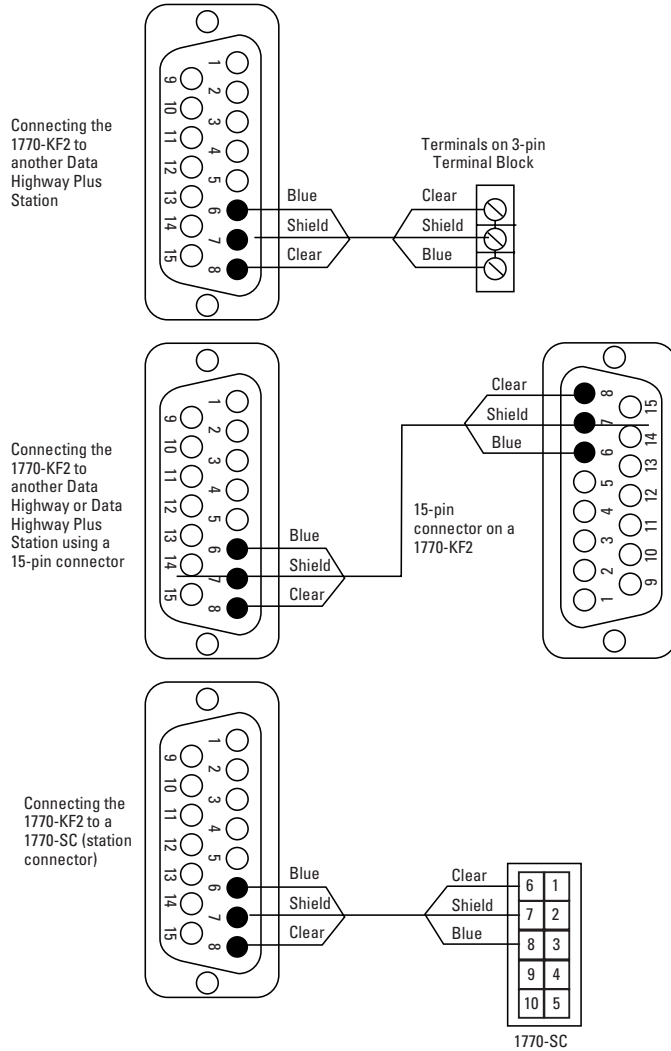

For details on constructing the dropline, refer to the Data Highway/Data Highway Plus/Data Highway II/Data Highway-485 Cable Installation Manual, publication 1770-6.2.2, April 1994.

## RS-232-A Cable Termination Resistor

The RS-422-A cable interface, as illustrated in Figure 3.6c of the user manual, may require cable termination resistors, shown in Figure 3, to ensure reliable operation. The optimum value of these resistors ranges from 90 to 150 ohms, depending on the cable type and length. Connect the resistors as close to the receiving ends of the cable as possible.

Some computers' RS-422-A compatible ports may already include this resistor, though pins may have to be jumpered to achieve the desired connections. Refer to your computer's manual for more information. If the resistor already exists on your computer port, attach an external resistor on only the 1770-KF2 end of the cable.

**Figure 3 RS-422-A Wiring Diagram with Terminating Resistors**

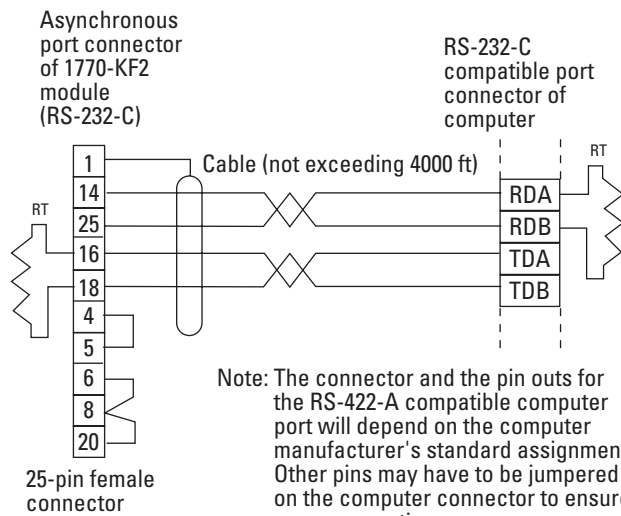

Note: The connector and the pin outs for the RS-422-A compatible computer port will depend on the computer manufacturer's standard assignment. Other pins may have to be jumpered on the computer connector to ensure proper operation.

RT = 1/2 watt termination resistor, typically 90 to 150 ohms.

31487-M

## Asynchronous Communication Rate (SW-6)

The 1770-KF2 module supports a data rate of 19,200 bits per second. Set the communication rate switches as shown in Table 1.

**Table 1 Communication Rate Switch Settings**

| Bits Per Second | Set Switch: |     |     |
|-----------------|-------------|-----|-----|
|                 | 1           | 2   | 3   |
| 110             | OFF         | OFF | OFF |
| 300             | ON          | OFF | OFF |
| 600             | OFF         | ON  | OFF |
| 1200            | ON          | ON  | OFF |
| 2400            | OFF         | OFF | ON  |
| 4800            | ON          | OFF | ON  |
| 9600            | OFF         | ON  | ON  |
| 19200           | ON          | ON  | ON  |

## Factory Default Switch Settings

All switches are set as shown on the label on the bottom of the unit when the 1770-KF2 module is shipped.

## Delivery Order of Commands

---

**IMPORTANT**

If any node on a Data Highway, Data Highway Plus, or Data Highway II network initiates multiple commands, e.g., the initiating node sets multiple bits at any one time, the order in which those commands are executed at the remote node cannot be guaranteed.

---

The initiating node, the network, and the receiving node execute commands based on network conditions, including but not limited to:

- node buffering commands
- retries due to noise on the network

If your application requires that commands be delivered in a specific order, your logic must control the initiation of one command at a time on the network and verify delivery before initiating additional commands. This verification is completed by:

- a done bit or error bit in the PLC processor
- a reply message in a computer

A done bit or a successful reply should cause the next command to be initiated. If an error bit or a reply with a non-zero status is returned, you must decide the appropriate action based on your application.

**Notes:**

Allen-Bradley PLCs

# Rockwell Automation Support

Rockwell Automation provides technical information on the web to assist you in using our products. At <http://support.rockwellautomation.com>, you can find technical manuals, a knowledge base of FAQs, technical and application notes, sample code and links to software service packs, and a MySupport feature that you can customize to make the best use of these tools.

For an additional level of technical phone support for installation, configuration and troubleshooting, we offer TechConnect Support programs. For more information, contact your local distributor or Rockwell Automation representative, or visit <http://support.rockwellautomation.com>.

## Installation Assistance

If you experience a problem with a hardware module within the first 24 hours of installation, please review the information that's contained in this manual. You can also contact a special Customer Support number for initial help in getting your module up and running:

|                       |  |
|-----------------------|--|
| United States         | 1.440.646.3223<br>Monday – Friday, 8am – 5pm EST   |
| Outside United States | Please contact your local Rockwell Automation representative for any technical support issues. |

## New Product Satisfaction Return

Rockwell tests all of our products to ensure that they are fully operational when shipped from the manufacturing facility. However, if your product is not functioning and needs to be returned:

|                       |   |
|-----------------------|---|
| United States         | Contact your distributor. You must provide a Customer Support case number (see phone number above to obtain one) to your distributor in order to complete the return process. |
| Outside United States | Please contact your local Rockwell Automation representative for return procedure.  |

Data Highway, Data Highway Plus, Data Highway II, and PLC are trademarks of Rockwell Automation Inc.

[www.rockwellautomation.com](http://www.rockwellautomation.com)

### Corporate Headquarters

Rockwell Automation, 777 East Wisconsin Avenue, Suite 1400, Milwaukee, WI, 53202-5302 USA, Tel: (1) 414.212.5200, Fax: (1) 414.212.5201

### Headquarters for Allen-Bradley Products, Rockwell Software Products and Global Manufacturing Solutions

Americas: Rockwell Automation, 1201 South Second Street, Milwaukee, WI 53204-2496 USA, Tel: (1) 414.382.2000, Fax: (1) 414.382.4444

Europe: Rockwell Automation SA/NV, Vorstlaan/Boulevard du Souverain 36-BP 3A/B, 1170 Brussels, Belgium, Tel: (32) 2 663 0600, Fax: (32) 2 663 0640

Asia Pacific: Rockwell Automation, 27/F Citicorp Centre, 18 Whitfield Road, Causeway Bay, Hong Kong, Tel: (852) 2887 4788, Fax: (852) 2508 1846

### Headquarters for Dodge and Reliance Electric Products

Americas: Rockwell Automation, 6040 Ponders Court, Greenville, SC 29615-4617 USA, Tel: (1) 864.297.4800, Fax: (1) 864.281.2433

Europe: Rockwell Automation, Brühlstraße 22, D-74834 Elztal-Dallau, Germany, Tel: (49) 6261 9410, Fax: (49) 6261 17741

Asia Pacific: Rockwell Automation, 55 Newton Road, #11-01/02 Revenue House, Singapore 307987, Tel: (65) 351 6723, Fax: (65) 355 1733

Publication 1770-6.5.13-RN3 - April 2004

Supersedes Publication 1770-6.5.13-RN1 - May 1993 and 1770-6.5.13-RN2 - December 1995

PN 957899-13

Copyright © 2004 Rockwell Automation, Inc. All rights reserved. Printed in the U.S.A.