



Isolated 24V dc Output Module

(Cat. No. 1771-OQ Series B)

Contents

Use this document as a guide when installing the catalog number 1771-OQ Series B isolated dc output module.

To	See page
Important User Information	1
Preinstallation Considerations	3
Set the Jumper Configuration	3
Calculate Power Requirements	4
Key the Backplane Connector	5
Install the Field Wiring Arm	5
Connect Wiring to the Field Wiring Arm	6
Interpreting the Status Indicators	8
Replacing the Fuses	8
Specifications	9

Important User Information

Solid state equipment has operational characteristics differing from those of electromechanical equipment. *Safety Guidelines for the Application, Installation and Maintenance of Solid State Controls* (Publication SGI-1.1 available from your local Rockwell Automation sales office or online at <http://www.ab.com/manuals/gi>) describes some important differences between solid state equipment and hard-wired electromechanical devices. Because of this difference, and also because of the wide variety of uses for solid state equipment, all persons responsible for applying this equipment must satisfy themselves that each intended application of this equipment is acceptable.

In no event will Rockwell Automation, Inc. be responsible or liable for indirect or consequential damages resulting from the use or application of this equipment.

The examples and diagrams in this manual are included solely for illustrative purposes. Because of the many variables and requirements associated with any particular installation, Rockwell Automation, Inc. cannot assume responsibility or liability for actual use based on the examples and diagrams.

No patent liability is assumed by Rockwell Automation, Inc. with respect to use of information, circuits, equipment, or software described in this manual.

Reproduction of the contents of this manual, in whole or in part, without written permission of Rockwell Automation, Inc. is prohibited.

Allen-Bradley Parts

Throughout this manual we use notes to make you aware of safety considerations.

WARNING



Identifies information about practices or circumstances that can cause an explosion in a hazardous environment, which may lead to personal injury or death, property damage, or economic loss.

IMPORTANT

Identifies information that is critical for successful application and understanding of the product.

ATTENTION



Identifies information about practices or circumstances that can lead to personal injury or death, property damage, or economic loss. Attentions help you:

- identify a hazard
- avoid a hazard
- recognize the consequence

ATTENTION



Environment and Enclosure

This equipment is intended for use in a Pollution Degree 2 industrial environment, in overvoltage Category II applications (as defined in IEC publication 60664-1), at altitudes up to 2000 meters without derating. This equipment is considered Group 1, Class A industrial equipment according to IEC/CISPR Publication 11. Without appropriate precautions, there may be potential difficulties ensuring electromagnetic compatibility in other environments due to conducted as well as radiated disturbance.

This equipment is supplied as "open type" equipment. It must be mounted within an enclosure that is suitably designed for those specific environmental conditions that will be present and appropriately designed to prevent personal injury resulting from accessibility to live parts. The interior of the enclosure must be accessible only by the use of a tool. Subsequent sections of this publication may contain additional information regarding specific enclosure type ratings that are required to comply with certain product safety certifications.

See NEMA Standards publication 250 and IEC publication 60529, as applicable, for explanations of the degrees of protection provided by different types of enclosure. Also, see the appropriate sections in this publication, as well as the Allen-Bradley publication 1770-4.1 ("Industrial Automation Wiring and Grounding Guidelines"), for additional installation requirements pertaining to this equipment.

ATTENTION**Preventing Electrostatic Discharge**

This equipment is sensitive to electrostatic discharge, which can cause internal damage and affect normal operation. Follow these guidelines when you handle this equipment:

- Touch a grounded object to discharge potential static.
- Wear an approved grounding wriststrap.
- Do not touch connectors or pins on component boards.
- Do not touch circuit components inside the equipment.
- If available, use a static-safe workstation.
- When not in use, store the equipment in appropriate static-safe packaging.

Preinstallation Considerations

This module contains soldered jumpers which must be removed when using certain output devices, such as solenoids. These jumpers limit the effects of noise. These jumpers are not reusable. Make certain that you will not be using a particular output for other uses before clipping the jumper.

Set the Jumper Configuration

Your module contains a jumper for each output. Under normal conditions, these jumpers are left in the position as shipped. When using solenoids as an output device, remove the jumper on the circuit board. Removing the jumper changes the off-state clamping voltage from -0.7V dc to -15.7V dc. This decreases the turnoff time of the solenoid, allowing it to energize faster. Follow the procedure listed below for removing a jumper. Refer to Figure 1.

1. Remove the plastic cover on the left front side of the module by removing two screws.
2. Locate the jumper which corresponds to your output. **Note:** The jumpers are usually brown with a black band.
3. Clip both ends of the jumper with diagonal cutters.

ATTENTION

Do not use a soldering tool to remove the jumper. This could cause damage to the adjacent components or the entire circuit board.

4. Replace the cover and secure with two screws

**Figure 1
Configuration Jumper Locations**

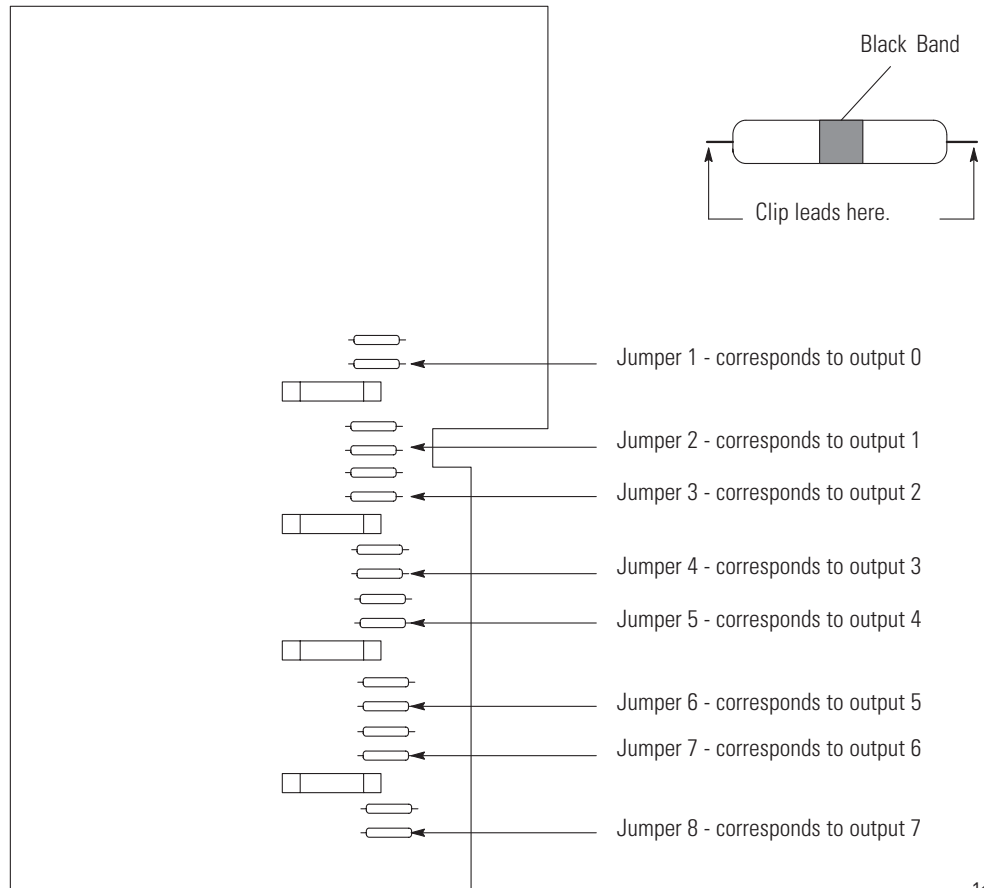

11065-I

Calculate Power Requirements

The module receives its power through the 1771 I/O chassis backplane from the chassis power supply. The module requires 225mA from the output of this supply .

Add this current to the requirements of all other modules in the I/O chassis to prevent overloading the chassis backplane and/or backplane power supply.

ATTENTION



Do not insert or remove modules from the I/O chassis while system power is applied. Failure to observe this rule could result in:

- module damage or degradation of performance
- injury or equipment damage due to possible unexpected operation.

Key the Backplane Connector

Place your module in any slot in the chassis except the leftmost slot which is reserved for processors or adapters.

ATTENTION



Observe the following precautions when inserting or removing keys:

- insert or remove keys with your fingers
- make sure that key placement is correct

Incorrect keying or the use of a tool can result in damage to the backplane connector and possible system faults.

Position the keying bands in the backplane connectors to correspond to the key slots on the module.

Place the keying bands:
- between 2 and 4
- between 10 and 12

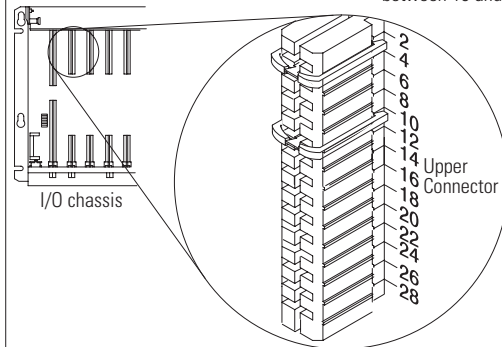

You can change the position of these bands if subsequent system design and rewiring makes insertion of a different type of module necessary.

11022-I

Install the Field Wiring Arm

ATTENTION



Remove power from the 1771 I/O chassis backplane and field wiring arm before removing or installing the I/O module. Failure to remove power from the backplane or wiring arm could cause:

- module damage, degradation of performance, or injury.
- injury or equipment damage due to possible unexpected operation.

1

Place the module in the card guides on the top and bottom of the chassis that guide the module into position.

Important: Apply firm even pressure on the module to seat it into its backplane connector.

1771-A1B, -A2B, -A3B, -A4B I/O chassis

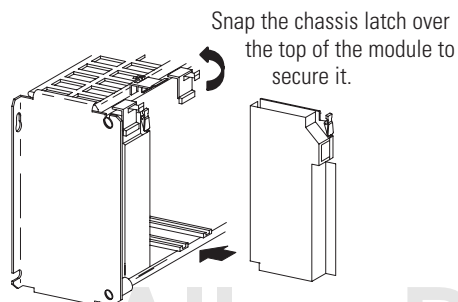

Snap the chassis latch over the top of the module to secure it.

1771-A1B, -A2B, -A4B Series B I/O chassis

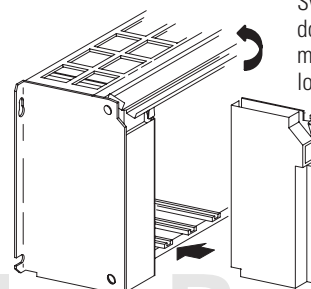

Swing the chassis locking bar down into place to secure the modules. Make sure the locking pins engage.

Allen-Bradley Parts

2

Attach the wiring arm (1771-WF) to the horizontal bar at the bottom of the I/O chassis.

The wiring arm pivots upward and connects with the module so you can install or remove the module without disconnecting the wires.

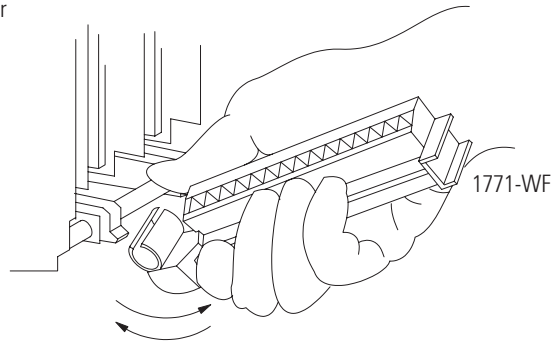

The 1771-OQ module is a modular component of the 1771 I/O system requiring a properly installed system chassis. Refer to publication 1771-IN075 for detailed information on acceptable chassis, proper installation, and grounding requirements. Limit the maximum adjacent slot power dissipation to 15.5W maximum.

Connect Wiring to the Field Wiring Arm

Make wiring connections to the module through the field wiring arm (cat. no. 1771-WF). The arm pivots on the I/O chassis to connect with terminals on the front of the module and acts as a terminal strip. The wiring arm allows the module to be removed from the chassis without disconnecting the wiring.

ATTENTION



Remove power from the 1771 I/O chassis backplane and field wiring arm before removing or installing the I/O module.

- Failure to remove power from the backplane or wiring arm could cause module damage, degradation of performance, or injury.
- Failure to remove power from the backplane could cause injury or equipment damage due to possible unexpected operation.

1. Make certain all power is removed from the module before making wiring connections.
2. Swing the wiring arm up into position on the front of the module. The locking tab on the module will secure it into place.

IMPORTANT

The field wiring arm terminal identification number is not the same as the number of the bit which controls that output

Figure 2
Connection Diagram

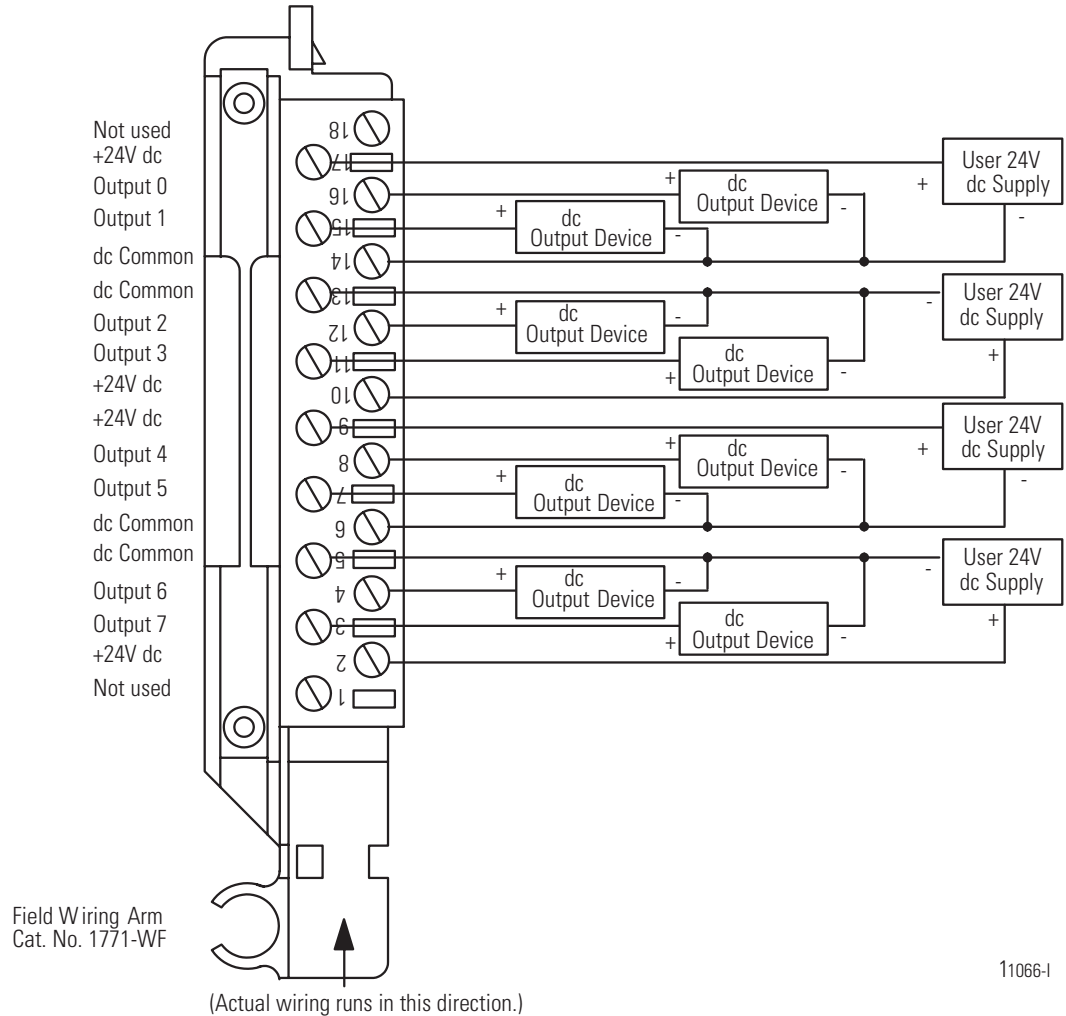

Connect your output device wiring to the field wiring arm as shown in Figure 2. Use two wires per output. Connect only one wire to a terminal. When multiple connections to a terminal are required, use an auxiliary terminal strip. Use stranded 14 gauge wire to minimize the voltage drop over long cable distances.

ATTENTION



Observe proper polarity with dc power connections. Reverse polarity, or application of ac voltage could damage the module.

Interpreting the Status Indicators

The front panel of your module contains 8 red status indicators (below). The red status indicators are on when the associated output is on.

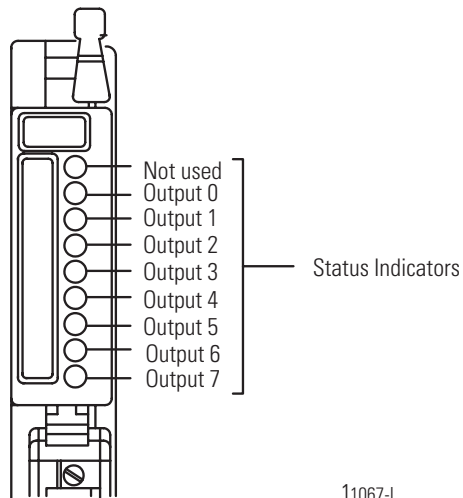

Replacing the Fuses

To replace a blown fuse, proceed as follows:

ATTENTION



Remove power from the 1771 I/O chassis backplane and field wiring arm before removing or installing an I/O module.

- Failure to remove power from the backplane or wiring arm could cause module damage, degradation of performance, or injury.
- Failure to remove power from the backplane could cause injury or equipment damage due to possible unexpected operation.

1. Turn off power to the chassis.
2. Remove the module from the I/O chassis.
3. Remove the 2 screws securing the front cover on the unlabelled side of the module. Note: One fuse protects 2 outputs.
4. Remove the blown fuse from fuse holder, and replace with a 2.5A, 3AG normal blow fuse.
5. Replace the cover and secure with screws removed in step 3.
6. Reinsert the module into I/O chassis.
7. Turn on power to chassis.

Specifications

Specifications	
Outputs per Module	8 (4 groups of 2, each group sharing a common dc supply)
Module Location	1771-A1B, thru -A4B or later I/O chassis
Output Voltage Range	24V dc, 2.25A, 4A inrush derated linearly from 37°C to 1.25A, 24V dc @ 60°C 2.25A per group derated linearly from 37°C to 1.25A
Maximum Output Current	2.25A per output 2.25A per group 9.0A per module
Maximum Surge Current	4.0A for 10ms per output
Maximum On-state Voltage Drop	2V dc @ 2.25A
Maximum Off-stage Leakage Current	1.0mA per output @ 34V dc, 25°C
Maximum Power Rating	4.5W per output
Output Signal Delay	10ms on or off
Power Dissipation	19.1W (max.), 1.1W (min.)
Thermal Dissipation	65.1 BTU/hr (max.), 3.75 BTU/hr (min.)
Backplane Current	225mA @ 5V
Isolation Voltage	50V continuous, tested to withstand 500V for 60s
Environmental Conditions	
Operating Temperature	IEC 60068-2-1 (Test Ad, Operating Cold), IEC 60068-2-2 (Test Bd, Operating Dry Heat), IEC 60068-2-14 (Test Nb, Operating Thermal Shock): 0 to 60°C (32 to 140°F)
Storage Temperature	IEC 60068-2-1 (Test Ab, Unpackaged Nonoperating Cold), IEC 60068-2-2 (Test Bb, Unpackaged Nonoperating Dry Heat), IEC 60068-2-14 (Test Na, Unpackaged Nonoperating Thermal Shock): -40 to 85°C (-40 to 185°F)
Relative Humidity	IEC 60068-2-30 (Test Db, Unpackaged Nonoperating Damp Heat): 5 to 95% noncondensing
Shock Operating Nonoperating	IEC 60068-2-27 (Test Ea, Unpackaged Shock): 30g 50g
Vibration	IEC 60068-2-6 (Test Fc, Operating): 2g @ 10-500Hz
Radiated RF Immunity	IEC 61000-4.3 10V/m with 1kHz sine-wave 80%AM from 30MHz to 1000MHz 10V/m with 200Hz 50% Pulse 100%AM at 900Mhz
EFT/B Immunity	IEC 61000-4.4 ±1kV at 5kHz on signal ports
Surge Transient Immunity	IEC 61000-4.5 ±1kV line-line(DM) and ±2kV line-earth(CM) on signal ports
Conducted RF Immunity	IEC 61000-4.6 10Vrms with 1kHz sine-wave 80%AM from 150kHz to 30MHz

Allen-Bradley Parts

Specifications	
Emmissions	CISPR 11 Group 1, Class A (with appropriate enclosure)
Enclosure Type Rating	None (open-style)
Fuse	2.5A, 250V normal blow fuse, Cooper Bussman AGC 2.5 or Littelfuse 31202.5
Field Wiring Arm	Cat. No. 1771-WF
Wiring Arm Screw Torque	7 pound-inches (0.8Nm)
Conductors	
Wire Size	14AWG (2.5mm ²) stranded copper rated at 60°C or greater
Category	3/64 inch (1.2mm) insulation (maximum) 2 ¹
Certification (when product is marked)	UL UL Listed Industrial Control Equipment CSA CSA Certified Process Control Equipment CE² European Union 89/336/EEC EMC Directive, compliant with: EN 50082-2, Industrial Immunity EN 61326, Meas./Control/Lab., Industrial Requirements EN 61000-6-2, Industrial Immunity EN 61000-6-4, Industrial Emissions C-Tick² Australian Radiocommunications Act, compliant with: AS/NZS CISPR 11, Industrial Emissions

1 You use this conductor category information for planning routing as described in publication 1770-4.1, Industrial Automation Wiring and Grounding Guidelines.
 2 See the Product Certification link at www.ab.com for Declarations of Conformity, Certificates and other certification details.

Derating Curve for the 1771-0Q Output Module

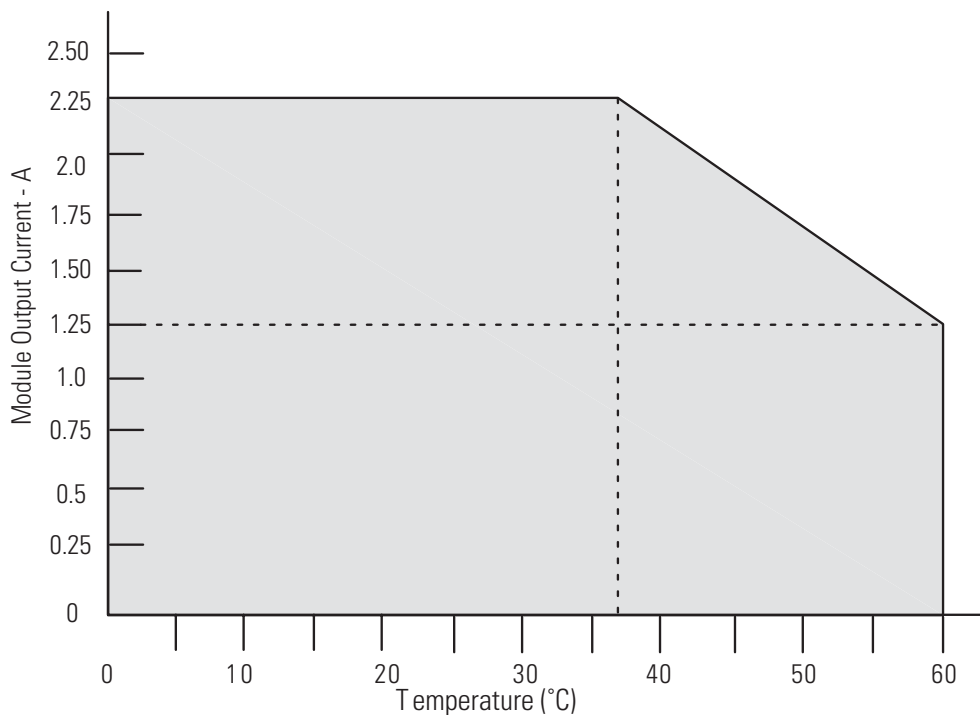

Allen-Bradley Parts

Rockwell Automation Support

Rockwell Automation provides technical information on the web to assist you in using our products. At <http://support.rockwellautomation.com>, you can find technical manuals, a knowledge base of FAQs, technical and application notes, sample code and links to software service packs, and a MySupport feature that you can customize to make the best use of these tools.

For an additional level of technical phone support for installation, configuration and troubleshooting, we offer TechConnect Support programs. For more information, contact your local distributor or Rockwell Automation representative, or visit <http://support.rockwellautomation.com>.

Installation Assistance

If you experience a problem with a hardware module within the first 24 hours of installation, please review the information that's contained in this manual. You can also contact a special Customer Support number for initial help in getting your module up and running:

United States	1.440.646.3223 Monday – Friday, 8am – 5pm EST
Outside United States	Please contact your local Rockwell Automation representative for any technical support issues.

New Product Satisfaction Return

Rockwell tests all of our products to ensure that they are fully operational when shipped from the manufacturing facility. However, if your product is not functioning and needs to be returned:

United States	Contact your distributor. You must provide a Customer Support case number (see phone number above to obtain one) to your distributor in order to complete the return process.
Outside United States	Please contact your local Rockwell Automation representative for return procedure.

www.rockwellautomation.com

Corporate Headquarters

Rockwell Automation, 777 East Wisconsin Avenue, Suite 1400, Milwaukee, WI, 53202-5302 USA, Tel: (1) 414.212.5200, Fax: (1) 414.212.5201

Headquarters for Allen-Bradley Products, Rockwell Software Products and Global Manufacturing Solutions

Americas: Rockwell Automation, 1201 South Second Street, Milwaukee, WI 53204-2496 USA, Tel: (1) 414.382.2000, Fax: (1) 414.382.4444

Europe: Rockwell Automation SA/NV, Vorstlaan/Boulevard du Souverain 36-BP 3A/B, 1170 Brussels, Belgium, Tel: (32) 2 663 0600, Fax: (32) 2 663 0640

Asia Pacific: Rockwell Automation, 27/F Citicorp Centre, 18 Whitfield Road, Causeway Bay, Hong Kong, Tel: (852) 2887 4788, Fax: (852) 2508 1846

Headquarters for Dodge and Reliance Electric Products

Americas: Rockwell Automation, 6040 Ponders Court, Greenville, SC 29615-4617 USA, Tel: (1) 864.297.4800, Fax: (1) 864.281.2433

Europe: Rockwell Automation, Brühlstraße 22, D-74834 Elztal-Dallau, Germany, Tel: (49) 6261 9410, Fax: (49) 6261 17741

Asia Pacific: Rockwell Automation, 55 Newton Road, #11-01/02 Revenue House, Singapore 307987, Tel: (65) 351 6723, Fax: (65) 355 1733

Publication 1771-IN081B-EN-P - June 2004

Supersedes Publication 1771-IN081A-EN-P - August 2003

PN 957899-57

Copyright © 2004 Rockwell Automation, Inc. All rights reserved. Printed in the U.S.A.