



DC Output Driver Module

Cat. No. 1771-OC

Installation Data

To The Installer

This document provides information on:

- important pre-installation considerations
- power supply requirements
- initial handling procedures
- installing the module
- using the indicators for troubleshooting
- module specifications

Pre-installation Considerations

The 1771-OC module can control the following output devices:

- dc motor starters
- indicators
- solenoids

Power Requirements

Your module receives its power through the 1771 I/O chassis backplane from the chassis power supply. The module requires 165mA from the output of this supply. Add this to the requirements of all other modules in the I/O chassis to prevent overloading the chassis backplane and/or backplane power supply.

Initial Handling

The dc output driver module is shipped in a static–shielded bag to guard against electrostatic discharge damage. Observe the following precautions when handling the module.

Electrostatic Discharge Damage



ATTENTION: Under some conditions, electrostatic discharge can degrade performance or damage the module. Observe the following precautions to guard against electrostatic damage.

- Wear an approved wrist strap grounding device, or touch a grounded object to discharge yourself before handling the module.
- Do not touch the backplane connector or connector pins.
- If you configure or replace internal components, do not touch other circuit components inside the module. If available, use a static–free work station.
- When not in use, keep the module in a static–shielded bag.

Installing Your Module

In this section we tell you how to key your I/O chassis, install your module and make your wiring connections.

Keying Your I/O Chassis

Use the plastic keying bands, shipped with each I/O chassis, to key the I/O slots to accept only this type of module.

The module circuit board is slotted in two places on the rear edge. The position of the keying bands on the backplane connector must correspond to these slots to allow insertion of the module. You can key any connector in an I/O chassis to receive this module except for the left–most connector reserved for adapter or processor modules. Place keying bands between the following numbers labeled on the backplane connector:

- Between 4 and 6
- Between 20 and 22

You can change the position of these keys if system redesign and rewiring makes insertion of a different module necessary.

Installing the Output Driver Module

To install the dc output driver module in your 1771 I/O chassis, follow the steps listed below.



ATTENTION: Remove power from the 1771 I/O chassis backplane and wiring arm before removing or installing an I/O module.

- Failure to remove power from the backplane or wiring arm could cause module damage, degradation of performance, or injury.
- Failure to remove power from the backplane could cause injury or equipment damage due to possible unexpected operation.

1. Turn off power to the I/O chassis.
2. Position the module so that the circuit board on the rear of the module lines up with the top and bottom card guides in the chassis.
3. Do not force the module into its backplane connector. Apply firm, even pressure on the module to seat it properly.
4. Snap the chassis latch over the top of the module to secure its position.
5. Connect the wiring arm to the module.
6. Make wiring connections to the field wiring arm as indicated in Figures 1 and 2.

Connecting Wiring to the Output Driver Module

Connections to the output driver module are made to the 10 terminal field wiring arm (cat. no. 1771-WA) shipped with the module. Attach the wiring arm to the pivot bar on the bottom of the I/O chassis. The wiring arm pivots upward and connects with the module so you can install or remove the module without disconnecting the wires.

Figure 1
Connection Diagram

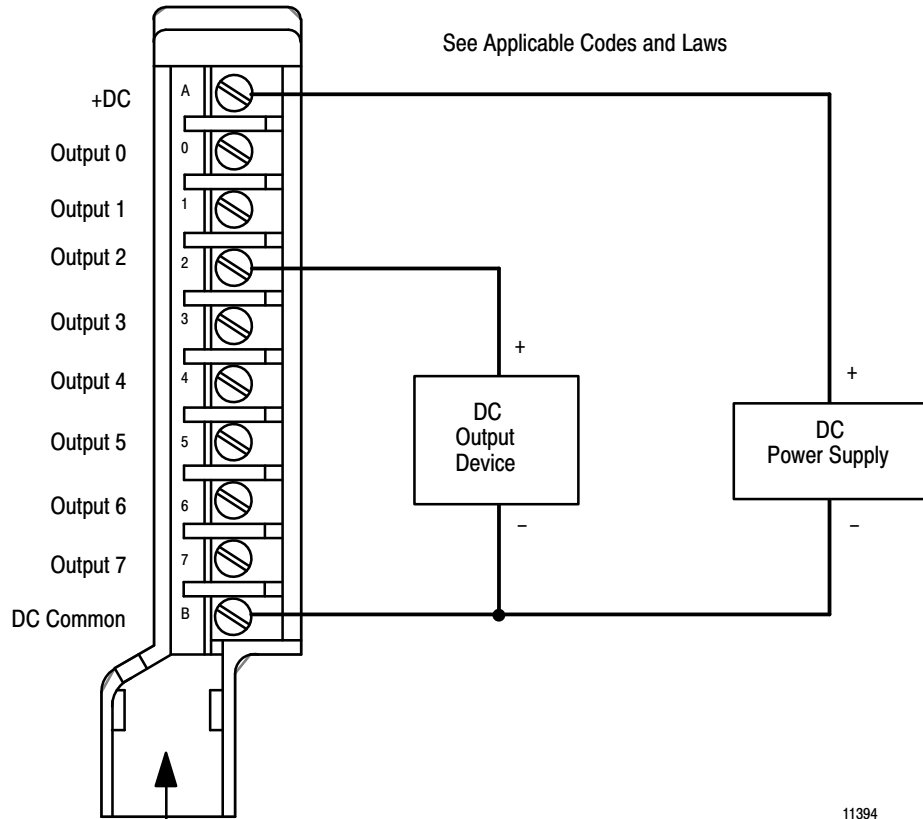

(Actual wiring runs in this direction.)

You must supply dc voltage to terminal A on the field wiring arm. Supply dc common to output devices and terminal B on the field wiring arm.



ATTENTION: Proper polarity, as indicated in the connection diagram (figure 1) must be observed with DC power connections. Reverse polarity, or incorrect application of 120V ac, may cause damage to the module.

Important: You can directly drive terminals on an DC (48V) Input Module (cat. no. 1771-IC) from terminals on the DC (48V) Output module (cat. no. 1771-OC).

Important: Use the same dc power source to power both modules to ensure that ground is at the same potential.

Figure 2
Driving an Input module with an Output module

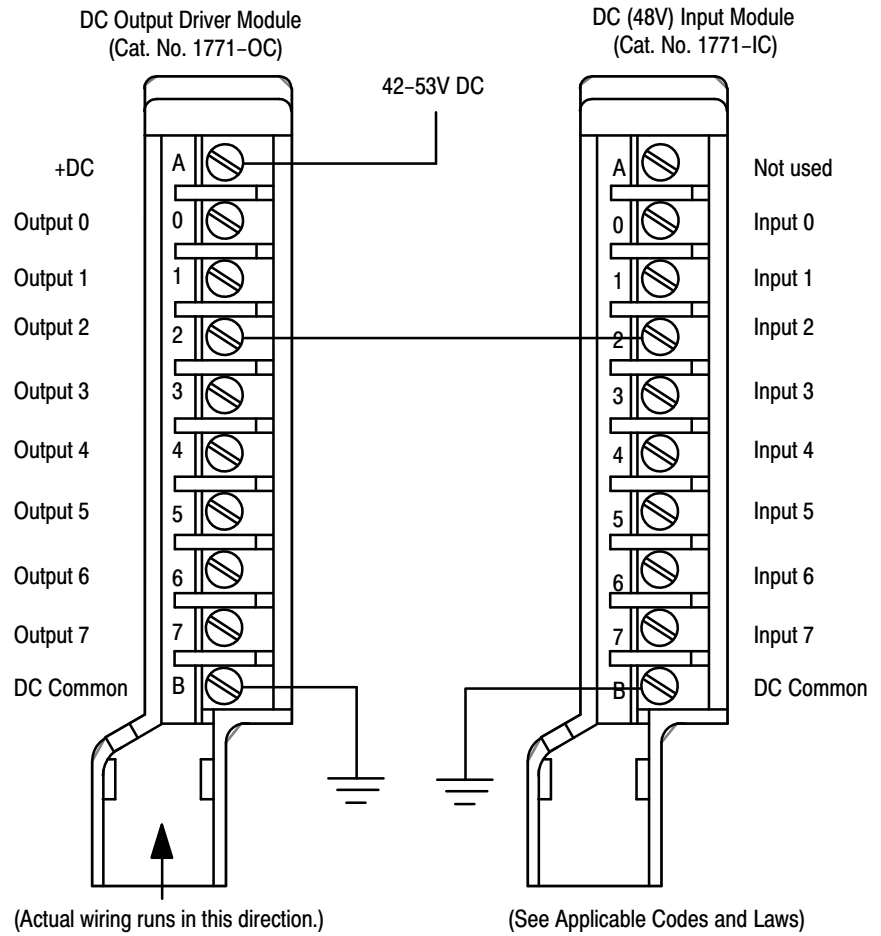

Interpreting the Status Indicators

The front panel of your module contains 9 red status LED indicators (Figure 3). The top LED is the fuse blown indicator. It illuminates when a fuse has blown in the module. The remaining 8 red status indicators correspond to each of the 8 inputs. They illuminate when the corresponding output energizes.

Figure 3
Status Indicators

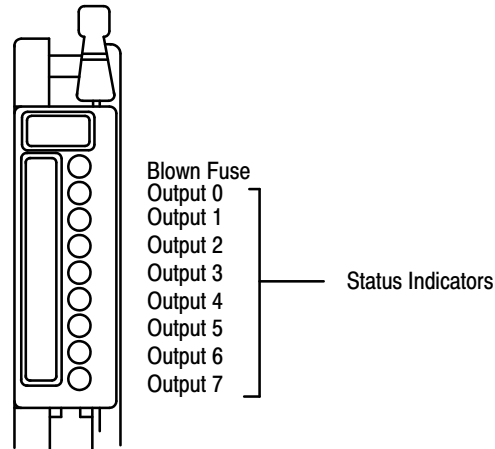

Replacing a Fuse

Each of the 8 outputs on the module are individually fused to protect the user's power supply. Fuses are accessed by removing the front component-side cover on the module.

If a blown fuse is indicated:

1. Turn off system power.



ATTENTION: Remove system power before removing or installing your module in the 1771 I/O chassis. Failure to observe this warning could result in damage to module circuitry and/or undesired operation with possible injury to personnel.

2. Pivot the field wiring arm away from the module, and remove the module from the chassis.
3. Remove the protective cover from the side of the module by removing the 2 screws.
4. Replace the blown fuse with a 2 amp 8AG normal blow fuse.
5. Reinstall the protective cover and reinstall the module in the chassis.
6. Reposition the field wiring arm on the module.

7. Restart system power.

Installation Data
DC Output Driver Module
Cat. No. 1771-OC

Installation Data
DC Output Driver Module
Cat. No. 1771-OC

Specifications

Outputs per Module	8
Module Location	1771 I/O chassis
Input Voltage Range	42 to 53V dc
Output Current	1.5A per output (not to exceed 8A per module)
Surge Current (maximum)	4A for 1ms, repeatable every 1 second
Off-state Leakage Current	1mA per output
On-state Voltage Drop	2V dc (maximum)
Signal Delay Time	Turn on/off: 10msec
Power Dissipation	16.9 Watts (max.), 0.9 Watts (min.)
Thermal Dissipation	57.6 BTU/hr (max.), 3.0 BTU/hr (min.)
Backplane Current	165mA @ 5V dc \pm 5%
Opto-electrical Isolation	1500V ac (RMS)
Environmental Conditions Operational Temperature Storage Temperature Relative Humidity	0° to 60°C (32° to 140°F) -40° to 85°C (-40° to 185°F) 5 to 95% (without condensation)
Conductors Wire Size Category	14 gage stranded maximum 3/64 inch insulation maximum 2 ¹
Keying	Between 4 and 6 Between 20 and 22
Fuses	2A 8AG (one per output)
Field Wiring Arm	Catalog Number 1771-WA

¹ Refer to publication 1770-4.1, Programmable Controller Wiring and Grounding Guidelines.

Installation Data
DC Output Driver Module
Cat. No. 1771-OC



As a subsidiary of Rockwell International, one of the world's largest technology companies — Allen-Bradley meets today's challenges of industrial automation with over 85 years of practical plant-floor experience. More than 11,000 employees throughout the world design, manufacture and apply a wide range of control and automation products and supporting services to help our customers continuously improve quality, productivity and time to market. These products and services not only control individual machines but integrate the manufacturing process, while providing access to vital plant floor data that can be used to support decision-making throughout the enterprise.

With offices in major cities worldwide

WORLD HEADQUARTERS
Allen-Bradley
1201 South Second Street
Milwaukee, WI 53204 USA
Tel: (1) 414 382-2000
Telex: 43 11 016
FAX: (1) 414 382-4444

EUROPE/MIDDLE EAST/AFRICA HEADQUARTERS
Allen-Bradley Europe B.V.
Amsterdamseweg 15
1422 AC Uithoorn
The Netherlands
Tel: (31) 2975/43500
Telex: (844) 18042
FAX: (31) 2975/60222

ASIA/PACIFIC HEADQUARTERS
Allen-Bradley (Hong Kong) Limited
Room 1006, Block B, Sea View Estate
28 Watson Road
Hong Kong
Tel: (852) 887-4788
Telex: (780) 64347
FAX: (852) 510-9436

CANADA HEADQUARTERS
Allen-Bradley Canada Limited
135 Dundas Street
Cambridge, Ontario N1R 5X1
Canada
Tel: (1) 519 623-1810
FAX: (1) 519 623-8930

LATIN AMERICA HEADQUARTERS
Allen-Bradley
1201 South Second Street
Milwaukee, WI 53204 USA
Tel: (1) 414 382-2000
Telex: 43 11 016
FAX: (1) 414 382-2400