



ALLEN-BRADLEY

Configurable Flowmeter Module

(Cat. No. 1771-CFM)

Product Data

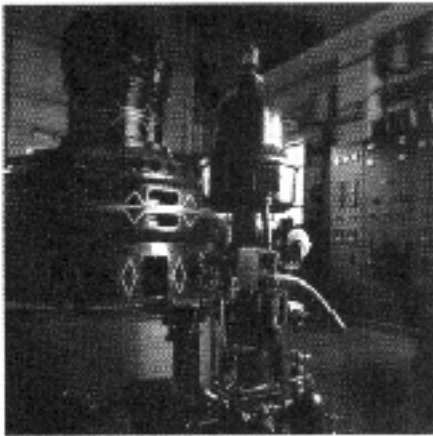

Calculate fast and accurate measurements for your flow-metering and/or shaft-speed applications.

The CFM module interfaces Allen-Bradley programmable logic controllers (PLCs[®]) with magnetic pickups, single-channel shaft encoders, turbine flowmeters or any source of TTL pulses to measure flow and shaft speed. Frequencies as high as 100kHz and counts as large as 9,999,999 are supported.

Using the CFM module to perform high-speed totalizing and/or frequency calculation operations:

- increases throughput
- lightens the burden on the PLC processor
- allows outputs (operated from the CFM module) to be tied to these calculated values

Allen-Bradley Spares

Typical Applications

You can use the CFM module in the power generation, automotive, food and beverage, and pipeline (oil, gas, etc.) industries for various flow and/or turbine metering applications. Some sample applications include:

SCADA Custom Application Routines (CARs — 6200-AGA and -API) let your 1785 PLC-5 processor perform American Gas Association (AGA) and American Petroleum Institute (API) volumetric and mass flow calculations for natural gas, crude oil and other liquid petroleum products.

The PLC-5 processor performs these calculations using data from the CFM module. This:

- eliminates the need for a flow computer
- simplifies programming
- conserves PLC-5 memory

turbine shaft speed monitoring

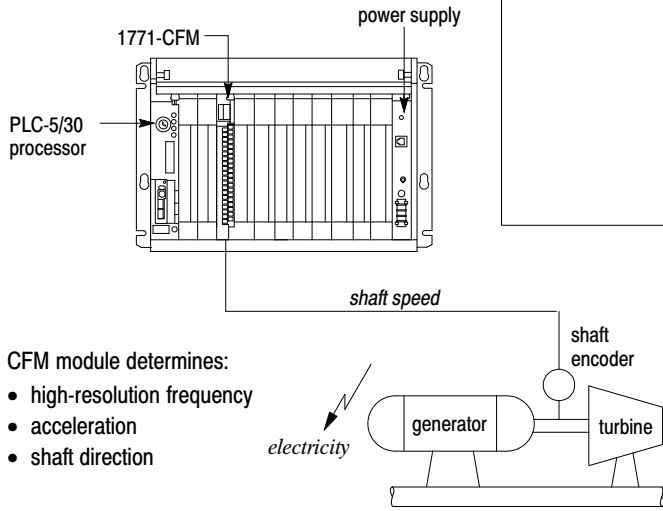

petrochemical flow and custody transfer

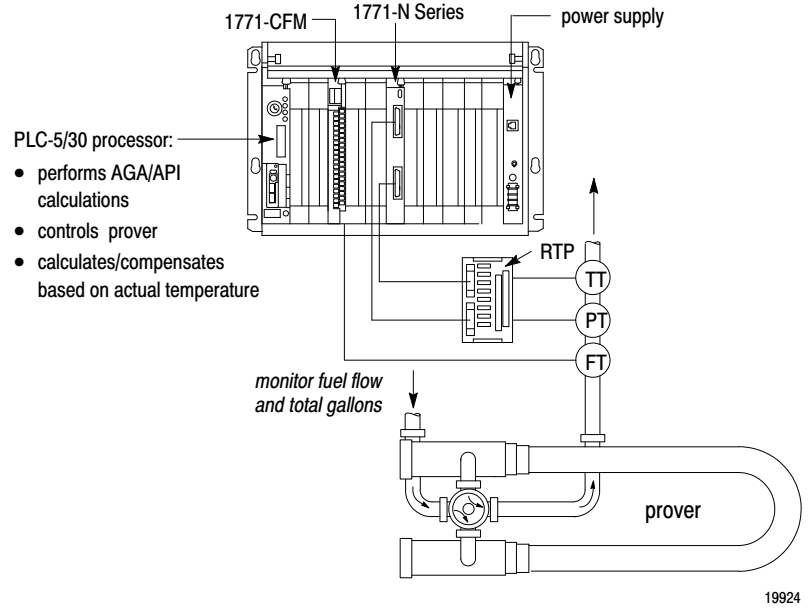

brewery flow monitoring

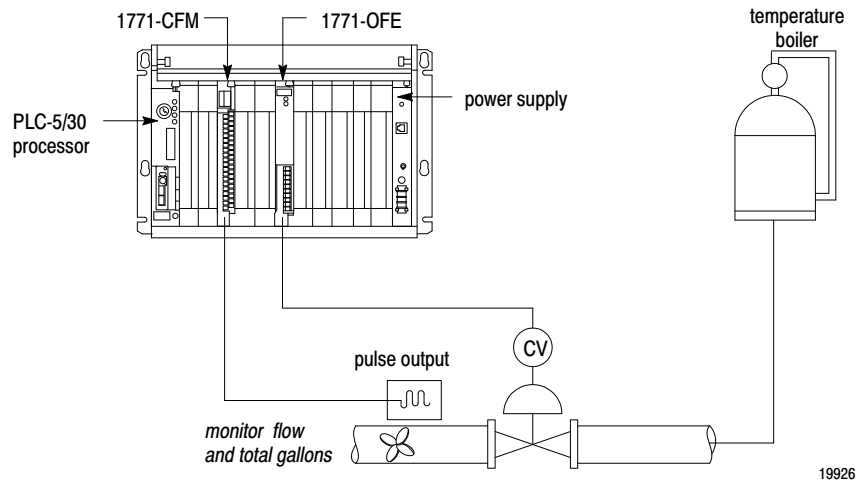

Introducing the CFM Module

The CFM module is a single-slot I/O module that interfaces between any Allen-Bradley PLC processor that has block-transfer capability and external I/O devices.

You can use the CFM module as a direct replacement for your 1771-QRC or 1771-QRD module by setting the CFM module's operation jumper and wiring your I/O devices to the new field wiring arm. When you use the CFM module as a direct replacement, you continue to program your block transfer instructions as before; no changes to ladder logic are necessary.

The CFM module has four input channels you can configure to:

- measure speed or frequency
- measure counts or volume
- interface to a prover — capture pulse counts during meter calibration using a liquid prover
- measure the direction of shaft rotation (uses two input channels)

The CFM module can control four outputs based on the values and status of the input channels. You can configure the outputs to trigger on (mode dependent):

- total counts
- frequency
- frequency change (acceleration)
- total overflow
- prover status
- shaft direction (clockwise / counterclockwise)

How The CFM Module Works

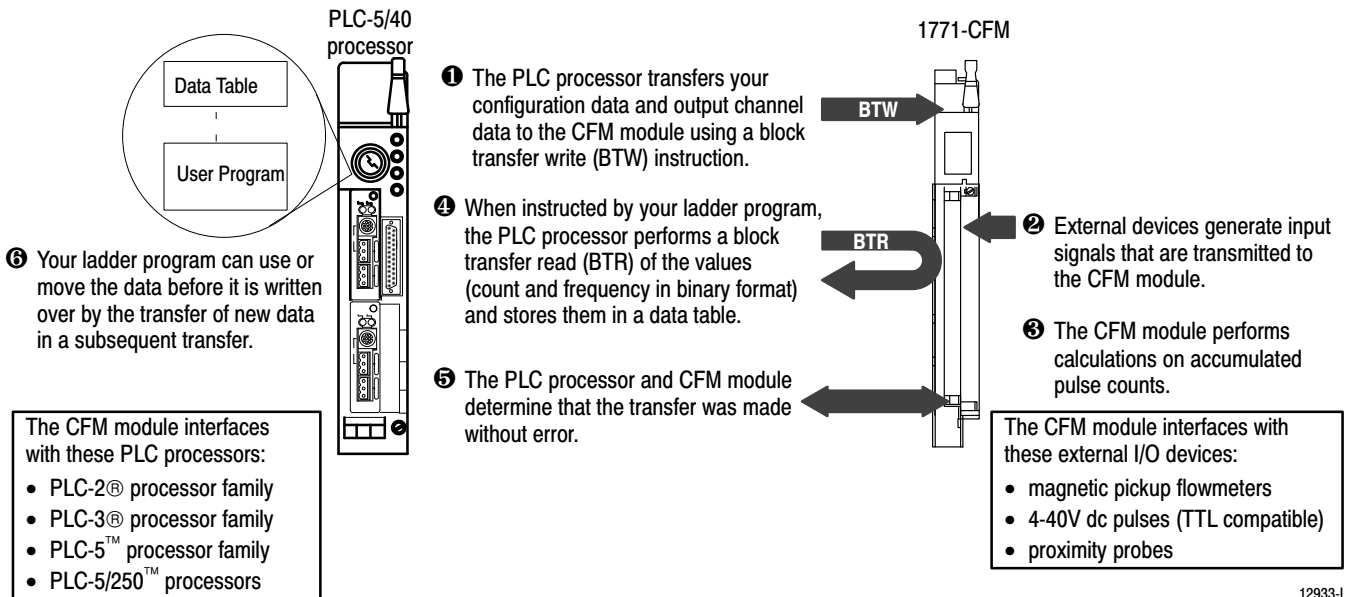

12933-1

Input/Output Capabilities

The CFM module:

- accepts input for up to four channels
 (mode dependent — specified modes use two input channels each)
- has four assignable outputs

Input

Each of the four input channels may accept these input signals:

- magnetic pickup — 50mV to 200V ac peak (optional 500mV to 200V ac peak for improved noise immunity)
- 4-40V dc pulses with open collector (TTL compatible)
- proximity probe inputs
 - compatible with Bently Nevada 3300 (5mm and 8mm) proximity transducer systems
 - provides two isolated 24V dc power supplies (rated at 12mA) to power external devices

You configure the CFM module's four input channels for your specific application(s). Each input channel has two input selections:

Flowmeter input (F0-F3) — you connect your input device to this input (ac, TTL).

Each flowmeter input has a corresponding flowmeter jumper. You can set each flowmeter jumper for low-pass filter (70Hz) or high-speed operation.

Gate input (G0-G3) — accepts 4-40V dc input pulse from open collector or external contact closure. Used in Totalizer and Nonresettable Totalizer modes to:

- store the current count of an input channel upon impulse on gate
- interface to a prover — used to store the count as the spheroid is sensed in the prover tube

Each gate input has a corresponding gate jumper. You can set each gate jumper for +5-12V or +12-40V operation.

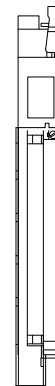

four input channels¹

flowmeter input (F0) gate input (G0)	Channel 0
flowmeter input (F1) gate input (G1)	Channel 1
flowmeter input (F2) gate input (G2)	Channel 2
flowmeter input (F3) gate input (G3)	Channel 3

¹ See page 11 for terminal connections.

To configure the CFM module, you set the appropriate bits in the BTW configuration block. You do this:

- through the I/O configuration utility if you are using a PLC-5 family processor (see *PLC-5 Programming Software I/O Configuration Software Manual*, publication 6200-6.4.12, for supported processors)
- or**
- by editing bits at the address of the BTW instruction

Selecting Mode(s) of Operation

If You Want To	Use This Mode
<ul style="list-style-type: none"> accurately accumulate counts using a flowmeter or positive displacement meter interface to a prover monitor meter pulse totals, frequency and acceleration independent of your PLC processor scan times store counts based on external input scale the frequency and count to engineering units trigger outputs directly from the CFM module — trigger on total, frequency or acceleration 	Totalizer mode
operate in the Totalizer mode with the count reset function disabled to prevent loss of accumulated value	Nonresettable Totalizer mode
<ul style="list-style-type: none"> monitor the frequency of an input with high accuracy (e.g. shaft) monitor acceleration scale the frequency to engineering units trigger outputs directly from the CFM module — trigger on frequency or acceleration 	High-resolution Frequency mode ¹ (channels 0&1 or channels 2&3)
<ul style="list-style-type: none"> monitor the direction of shaft rotation monitor frequency and acceleration scale the frequency and count to engineering units trigger outputs directly from the CFM module — trigger on direction, frequency or acceleration 	Direction Sensor mode ¹ (channels 0&1 or channels 2&3)

¹ This modes uses two channels for one input (your input device is connected to F0 or F2, while F1 or F3 is unused).

Using a Prover

A prover is used for the calibration of liquid meters in custody transfer applications. This calibration is done by comparing a metered throughput to a known volume in the prover. The number of pulses accumulated, while the spheroid moves between two detectors, is then compared to the predetermined volume of the prover section to ascertain the meter factor.

If you are using the Totalizer or Nonresettable Totalizer mode for capturing meter counts during a prover calibration, you have the option of selecting two types of provers:

- unidirectional** — the CFM module:
- begins counting when the spheroid passes the first detector
 - stops counting when the spheroid passes the second detector (*Prover Total Count Value* is updated at this time)
- ↔ bidirectional** — the CFM module:
- begins counting when the spheroid passes the first detector
 - stops counting when the spheroid passes the second detector (*Prover Total Count Value* is updated at this time - intermediate value returned)
 - continues counting when the spheroid returns past the second detector
 - stops counting when the spheroid returns past the first detector (*Prover Total Count Value* is updated at this time)

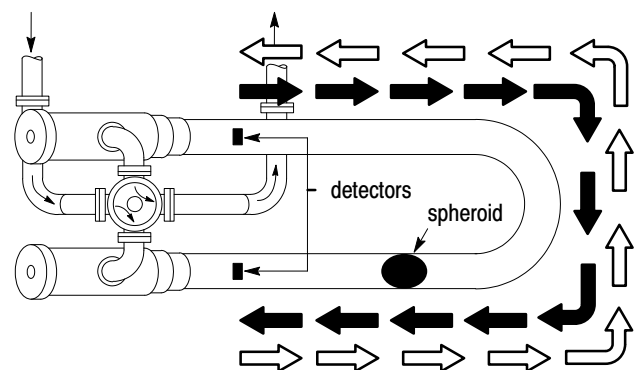

19884

Storing Current Count Values

If you are using the Totalizer or Nonresettable Totalizer mode and you are not using a prover, you can use the gate input to store the current count value of any (or all) of the four input channels.

The current count value of each channel is placed in a separate word in the BTR file (*Store Count Value*). The *Store Count Value* will remain in the BTR file until a new trigger pulse is received at the gate input. The *Store Count Value* is then updated to reflect the new value.

Output

The CFM module's four outputs are designed for applications that require fast response. The outputs:

- are electrically fused/current limited to 3A (output combinations are limited to 7A)
- can be assigned to any input channel with user-selectable turn-on and turn-off values
- are current sourcing at 5 to 40V dc (1A maximum per output)
- must be connected to an external power supply
- are in groups of two — this allows you to use two separate external power supplies if desired (one for outputs 0&1 and one for outputs 2&3)

Outputs may be forced on or off (independent of inputs) by setting bits in the BTW configuration block.

Important: You can assign as many as four outputs to a given channel; however, you cannot use the same output with two different channels.

In This Mode Of Operation	You Can Assign Outputs That Are Programmable To Trigger
Totalizer	on total, frequency, acceleration, total overflow, or prover status
Nonresettable Totalizer	on total, frequency, acceleration, total overflow, or prover status
High-resolution Frequency	on frequency or acceleration
Direction Sensor	ON on either CLOCKWISE or COUNTER-CLOCKWISE direction, acceleration or frequency

Implementing Application Features

You can use the CFM module to implement programmable application features that are usually initiated by your PLC processor; this frees the PLC processor to do other tasks and helps increase the overall throughput of your PLC system.

This Feature	Is Used In These Modes	To
overflow indication	Totalizer Nonresettable Totalizer	set an overflow flag when the count is > rollover (programmable — default = 9,999,999).
overrange alarm	all	activate overrange alarm when frequency is > 100kHz.
overspeed alarm	all	activate overspeed alarm when frequency is > user-specified frequency value.
acceleration alarm	all	activate acceleration alarm when acceleration is > user-specified acceleration value.

Modes of Operation

You select the mode(s) of operation and configure each input channel to accept input signals from your input device(s).

Use Totalizer mode if you:

- need counting (totalization) capabilities
- can measure frequency over a fixed sampling period (4ms-1s)
- need a frequency value
- need prover capabilities
- need count storage capabilities
- also want to calculate acceleration

Use Nonresettable Totalizer mode if you want to use the features of the Totalizer mode with NO software reset capabilities.

Typical applications:

- measuring ingredients in a batch process
- oil pipeline terminals (prover)

Totalizer and Nonresettable Totalizer Modes

These modes measure incoming pulses over a user-specified time interval (4-1000ms). In either of these modes, the CFM module calculates:

- frequency (0-100,000 Hz)
- total count (0-9,999,999)
- acceleration value (optional)
- prover value (optional)
- store count value — current count value (optional)

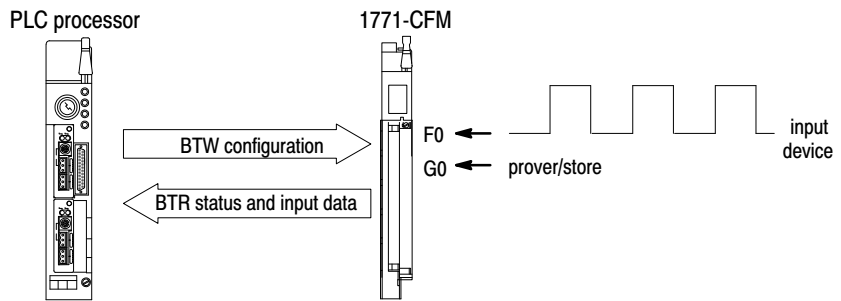

Counting

In these modes, the CFM module counts pulses based on:

Value	Used To
<i>Rollover</i>	specify the value at which the CFM module will rollover to zero and begin counting again. DEFAULT: 0 = 10,000,000 RANGE: 0-9,999,999
<i>Overflow Reset</i>	resets the overflow status of the CFM module for the appropriate input channel.
<i>Total Reset (Totalizer mode only)</i>	reset the total count to zero.
<i>Total Scaler Multiplier</i>	scale the returned total count to actual engineering units.
<i>Total Scaler Divisor</i>	For each value RANGE: 0-32,767 DEFAULT: 1

Frequency Sampling

In the Totalizer and Nonresettable Totalizer modes, the CFM module begins a frequency sample arbitrarily and ends the sampling within 1ms after the sampling time has expired and one pulse has been detected.

In these modes, the CFM module calculates frequency based on:

Value	Used To
<i>Minimum Frequency Sampling Time</i>	specify the minimum time the CFM module will spend collecting pulses to determine a frequency. The time period begins arbitrarily.
<i>Bandwidth Limit</i>	control the maximum time the CFM module spends calculating a frequency and the minimum frequency that can be read by the CFM module. If ON: limits the maximum time period to 2 x <i>Minimum Frequency Sampling Time</i> and minimum frequency read to 1/ <i>Minimum Frequency Sampling Time</i> . If OFF: maximum time period is 2s, minimum frequency is 1Hz.
<i>Acceleration Calculation Time</i>	specify the number of frequency samples the CFM module will spend to calculate the acceleration value. The default value (0) will calculate a rolling average of the previous five samples.
<i>Acceleration Alarm</i>	determine the acceleration value that, if exceeded, will activate the BTR <i>Acceleration Alarm</i> . RANGE: 0-32,767 DEFAULT: 0 (= OFF)
<i>Frequency Multiplier/Divisor</i>	scale the returned frequency and acceleration to actual engineering units. <i>Frequency Multiplier must be < Frequency Divisor</i> . For each value RANGE: 0-255 DEFAULT: 0 (= 1 no scaling)
<i>Highest Allowable Frequency</i>	specify the highest frequency value allowed on the input channel. When this value is exceeded, the input channel's overspeed alarm will activate.

Storing Count Values

In the Totalizer and Nonresettable Totalizer modes, the CFM module stores the current count based on:

Value	Used To
<i>Prover Run Initialize</i>	initialize an input channel for prover inputs on the gate or store current count value (if prover not used). If OFF (=0) — CFM module stores the current count every time there is a low to high transition at the appropriate gate input terminal. As each value is stored, the <i>Prover Status</i> (BTR words 4 & 5, bits 4-6) will be updated to indicate a new value. If ON (= 1) — the CFM module resets to 0 any previously stored count contained in the <i>Store Count Value</i> (in the BTR) and then waits for the proper number of gate transitions (2 for unidirectional and 4 for bidirectional) to occur. As the gate transitions occur, <i>Prover Status</i> (in the BTR) is updated accordingly, dependent upon the current state of the prover. A mid-run value is returned when prover type is bidirectional.
<i>Debounce Filtering</i>	debounce gate input for a period of 1s. If ON: CFM module takes appropriate action at the first low to high transition (at the gate input) and ignores all other gate transitions for 1s. If OFF: CFM module takes appropriate action at every low to high transition (at the gate input).

High-resolution Frequency Mode

Use this mode if you:

- need accurate frequency value (see page 14 for frequency accuracy)
- need fastest possible sample update time across large frequency range
- want to calculate acceleration
- need to measure frequency in 10ths of Hz (0.1Hz)

Typical application:

measuring shaft speed of turbine generators

This mode measures incoming pulses over a user-specified time interval (4-1000ms) **or** over a user-specified number of input signal pulses. In this mode, the CFM module calculates:

- frequency (0-100,000 Hz)
- acceleration value

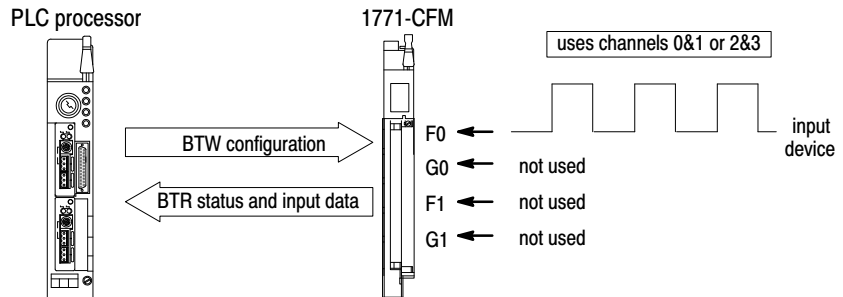

Frequency Sampling

In this mode, frequency sampling begins on the first pulse to occur and ends on the next pulse to occur after the sampling time has expired or after the user-specified number of pulses has occurred. In this mode, the CFM module calculates frequency based on:

Value	Used To
<i>Minimum Frequency Sampling Time</i>	specify the minimum time the CFM module will spend collecting pulses to determine a frequency.
<i>Sampling Termination</i>	terminate the sampling on either a time base or a set number of pulses, depending on which occurs first.
<i>Bandwidth Limit</i>	control the maximum time the CFM module spends calculating a frequency and the minimum frequency that can be read by the CFM module.
<i>Acceleration Calculation Time</i>	specify the number of frequency samples the CFM module will spend to calculate the acceleration value. The default value (0) will calculate a rolling average of the previous five samples. Since the actual sample time can vary, so does the <i>Acceleration Calculation Time</i> .
<i>Acceleration Alarm</i>	determine the acceleration value that, if exceeded, will activate the <i>Acceleration Alarm</i> in the BTR. The CFM module will not calculate an acceleration if this acceleration value is zero. RANGE: 0-32,767
<i>Number of Pulses to Terminate Sampling</i>	terminate the sampling when the specified number of input pulses are received.
<i>Highest Allowable Frequency</i>	specify the highest frequency value allowed on the input channel. When this value is exceeded, the input channel's overspeed alarm will activate.
<i>Frequency Scaler Multiplier/Divisor</i>	scale the returned frequency to actual engineering units. For each value RANGE: 1-255 DEFAULT: 1 <i>Frequency Multiplier must be < Frequency Divisor</i> . The scaled frequency value can not be used to trigger any outputs (outputs triggered by frequency are triggered by actual frequency).

Direction Sensor Mode

Use this mode if you want to determine shaft direction.

Typical applications:

turbine generators
pumps

Use this mode to measure shaft direction. In this mode, the CFM module calculates:

- frequency (0-100,000 Hz)
- acceleration value
- direction of shaft

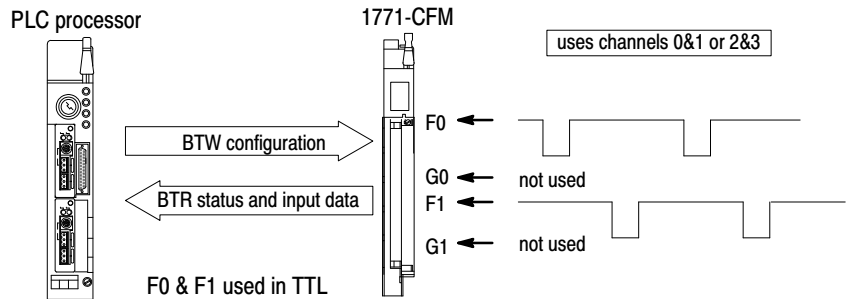

Frequency Sampling

In this mode, frequency samples are taken every revolution by measuring A and B:

- A = the time between F0 input channel pulses (to determine frequency of the shaft)
- B = the time between F0 and F1 input channel pulses (to determine direction of the shaft)

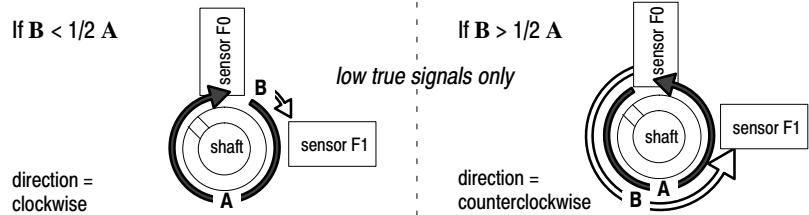

In this mode, the CFM module calculates frequency based on:

Value	Used To
<i>Minimum Frequency Sampling Time</i>	determine the minimum frequency and maximum sample time. All sample times are based on the time between F0 or F2 pulses.
<i>Bandwidth Limit</i>	control the maximum time the CFM module spends calculating a frequency and the minimum frequency that can be read by the CFM module. If ON: limits the maximum time period to 2 x <i>Minimum Frequency Sampling Time</i> and minimum frequency to 1/ <i>Minimum Frequency Sampling Time</i> . Frequencies < 1/ <i>Minimum Frequency Sampling Time</i> are reported as stopped. If OFF: maximum time period is 3s, minimum frequency is 1Hz and Direction can be sensed to 1/3Hz. <i>Minimum Frequency Sampling Time</i> is not used if <i>Bandwidth Limit</i> is OFF (= 0).
<i>Acceleration Calculation Time</i>	specify the number of frequency samples the CFM module will spend to calculate the acceleration value. The default value (0) will calculate a rolling average of the previous five samples.
<i>Acceleration Alarm</i>	determine the acceleration value that, if exceeded, will activate the <i>Acceleration Alarm</i> in the BTR. RANGE: 0-32,767
<i>Frequency Multiplier/Divisor</i>	scale the returned frequency to actual engineering units. For each value RANGE: 1-255 DEFAULT: 1
<i>Highest Allowable Frequency</i>	specify the highest frequency value allowed on the input channel. When this value is exceeded, the input channel's overspeed alarm will activate.

Related Documentation

Document	Publication Number
Configurable Flowmeter Module User Manual	1771-6.5.99
SCADA Custom Application Routines (CARs) for Gas and Liquid Petroleum Flow Calculations Product Profile	6200-1.22
PLC-5 Volume Flow CARs for Orifice Metering User Manual	6200-6.5.17
PLC-5 Volumetric Flow CARs for Turbine and Displacement Metering User Manual	6200-6.5.18

Specifications

Field Wiring Arm

You connect your I/O devices to a 40-terminal field wiring arm (cat. no. 1771-WN) that is shipped with the CFM module. See the wiring diagrams on pages 12 and 13 for example wiring.

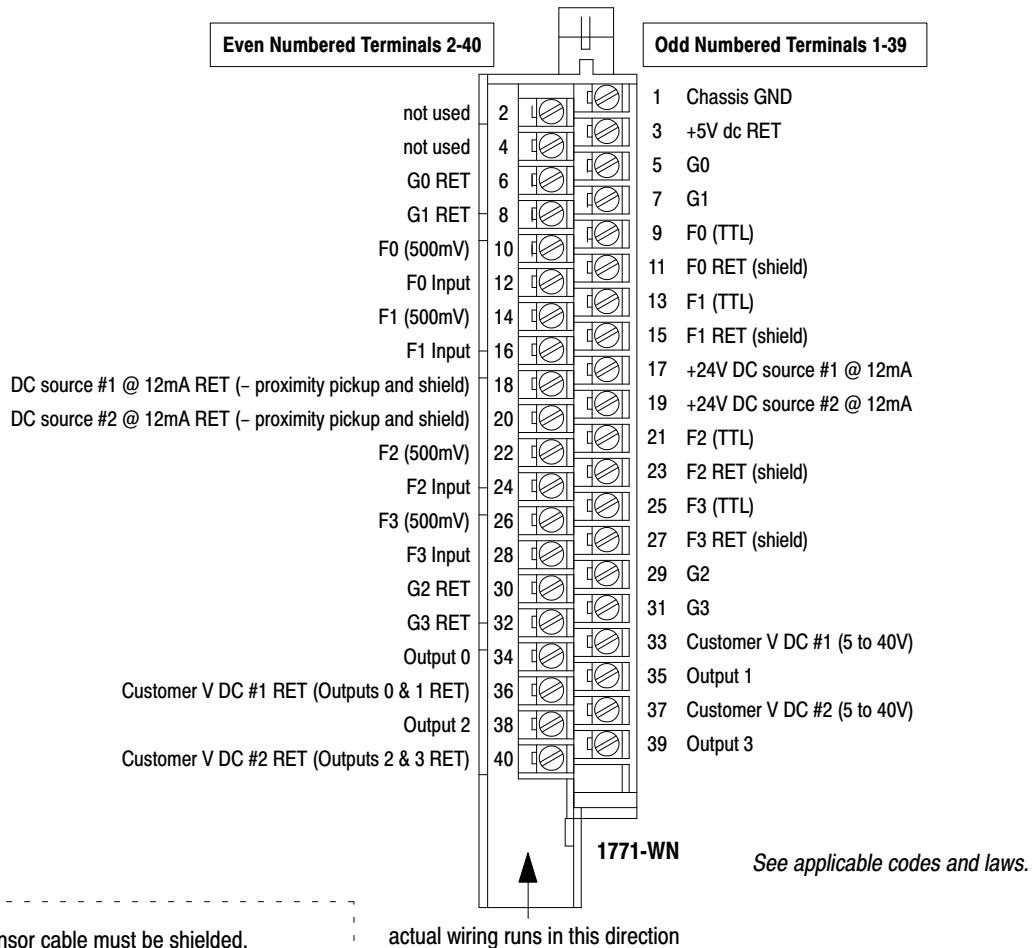

The sensor cable must be shielded.
The shield must extend the length of the cable, but be connected only at the CFM end.

Wiring Examples

These wiring diagrams represent wiring for a flowmeter input (F0), a gate input (G0) and an output (O0). See the wiring arm diagram on page 11 for the terminals used in wiring F1-F3, G1-G3 and O1-O3.

Standard Magnetic Pickup
 50mV threshold (F0)

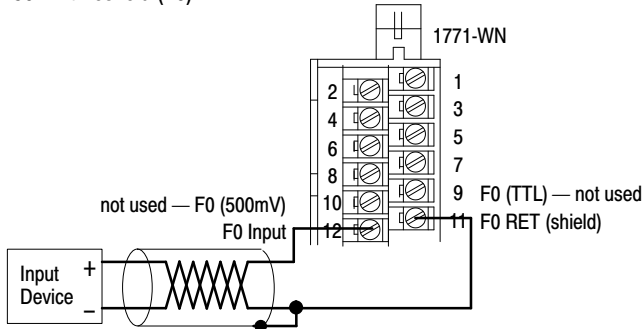

Standard Magnetic Pickup
 500mV threshold (F0)

Important: To use a channel for 500mV sensor, jumper the 500mV pin to the appropriate RET. For Channel 0, jumper pin 10 to pin 11.

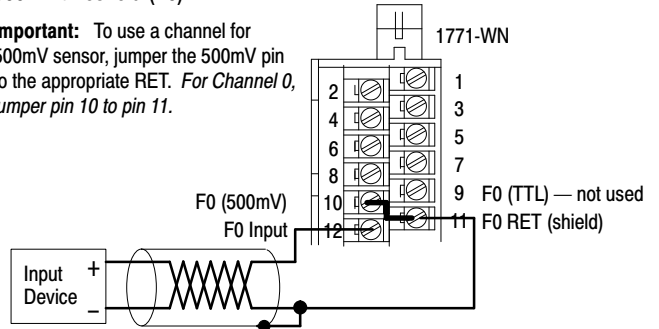

Standard Proximity
 using CFM Module Source (F0)

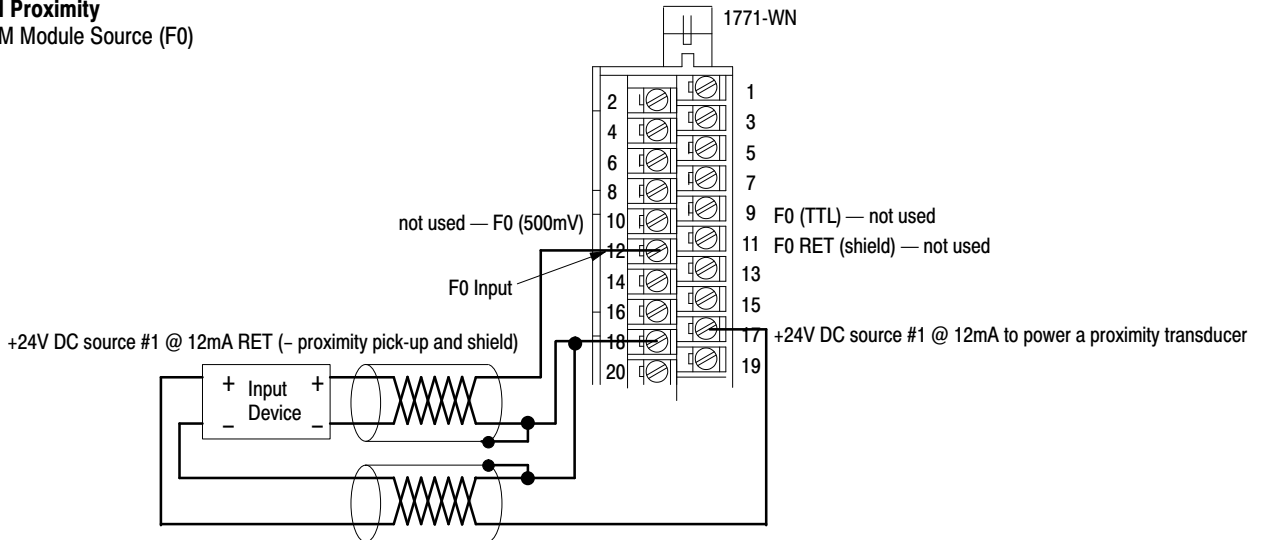

Standard TTL or Open Collector
 1.3V threshold (F0)

Important: To use a channel in TTL, jumper the appropriate TTL pin to the appropriate RET. To use Channel 0 in TTL, jumper pin 9 to pin 11.

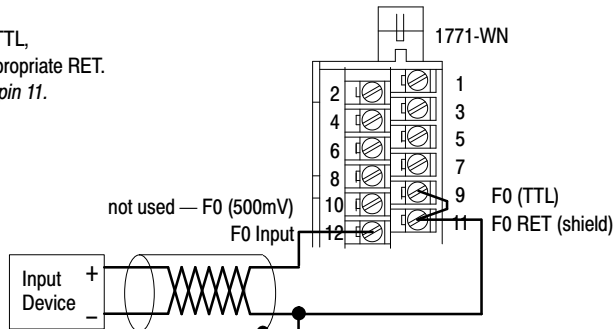

Wiring Examples (continued)

Standard Prover/Store Count (G0)

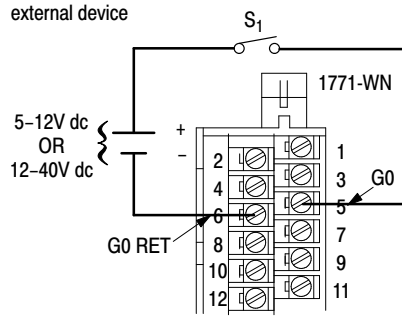

Standard Output (O0)

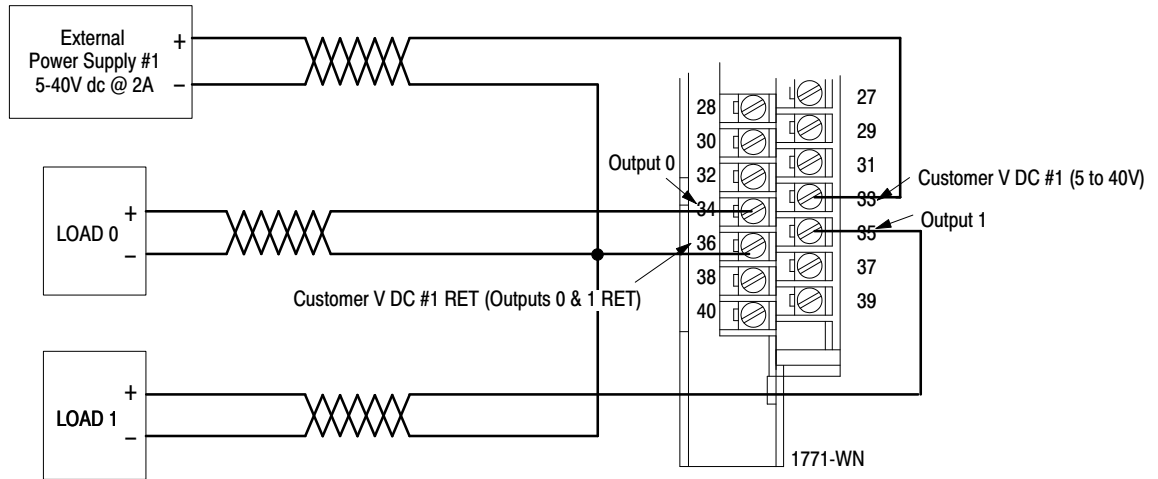

Frequency Accuracy

The following table lists typical application configurations and their associated frequency accuracy. The accuracy in all configurations will vary with input frequency, mode of operation and frequency sample time.

CFM Module					
Mode(s)	Minimum Frequency Sampling Time (4-1000ms)	Frequency Range (0-120,000Hz)	Maximum Frequency Error (expressed as Hz or % of frequency input)		
			25°C	40°C	60°C
Totalizer & Nonresettable Totalizer ²	100	0 – 10	±1Hz ¹	±1Hz ¹	±1Hz ¹
		11 – 2,000	±10Hz	±10Hz	±10Hz
		2,001 – 18,000	±0.180%	±0.180%	±0.20%
18,001 – 120,000		±0.100%	±0.120%	±0.150%	
500	0 – 50	±1Hz ¹	±1Hz ¹	±1Hz ¹	
	51 – 8,000	±2Hz	±2Hz	±3Hz	
	8,001 – 20,000	±0.03%	±0.03%	±0.035%	
	20,001 – 120,000	±0.025%	±0.0275%	±0.03%	
1000	0 – 6,000	±1Hz ¹	±1Hz ¹	±1Hz ¹	
	6,001 – 120,000	±0.020%	±0.025%	±0.030%	
High-resolution Frequency (time only)	4	0 – 6,000	±1Hz ¹	±1Hz ¹	±1Hz ¹
		6,001 – 14,000	±1Hz ¹	±1Hz ¹	±0.020%
		14,001 – 120,000	±0.0150%	±0.020%	±0.025%
		0 – 6,000	±1Hz ¹	±1Hz ¹	±1Hz ¹
	10	6,001 – 14,000	±1Hz ¹	±1Hz ¹	±0.015%
		14,001 – 20,000	±1Hz ¹	±0.007%	±0.015%
		20,001 – 120,000	±0.007%	±0.007%	±0.015%
		0 – 6,000	±1Hz ¹	±1Hz ¹	±1Hz ¹
	100	6,001 – 14,000	±1Hz ¹	±1Hz ¹	±0.015%
		14,001 – 20,000	±1Hz ¹	±0.007%	±0.015%
		20,001 – 120,000	±0.005%	±0.007%	±0.015%
		0 – 6,000	±1Hz ¹	±1Hz ¹	±1Hz ¹
1000	6,001 – 14,000	±1Hz ¹	±1Hz ¹	±0.015%	
	14,001 – 20,000	±1Hz ¹	±0.007%	±0.015%	
	20,001 – 120,000	±0.005%	±0.007%	±0.015%	
	0 – 2,000	±1Hz ¹	±1Hz ¹	±1Hz ¹	
Direction Sensor	not applicable	2,001 – 30,000	±0.550%	±0.550%	±0.550%
		30,001 – 120,000	±2.500%	±2.500%	±2.500%
QRC / QRD Module Emulation					
CFM Module Configured For	Frequency Sampling Time	Frequency Range (0-120,000Hz)	Maximum Frequency Error (expressed as Hz or % of frequency input)		
			25°C	40°C	60°C
QRC operation	constant @ 12ms	0 – 6,000	±1Hz ¹	±1Hz ¹	±1Hz ¹
		6,001 – 14,000	±1Hz ¹	±1Hz ¹	±0.015%
		14,001 – 15,800	±1Hz ¹	±0.007%	±0.015%
QRD operation	constant @ 1s	0 – 6,000	±1Hz ¹	±1Hz ¹	±1Hz ¹
		6,001 – 10,000	±0.080%	±0.090%	±0.10%

¹ Specified 1Hz is worst case — typical performance is expected to be better than ±1Hz.

² In Totalizer and Nonresettable Totalizer, frequencies input slightly above 1/Minimum Frequency Sampling Time may result in an inaccurate frequency (approximately twice the actual frequency) because the incoming pulses and sample time are not synchronized.

General Specifications

Number of Input Channels	4			
Module Location	1771-A1B, -A2B, A3B, -A3B1, -A4B (series A and B) I/O chassis 1771-AM1, -AM2 I/O chassis with integral power supply, adapter			
Maximum Count Value	0-9,999,999 (programmable)			
BTW Processing Time (worst case)	5.5ms — on a configuration change			
Module Scan Time	1.3-5ms (depending on configuration and frequency)			
Maximum Input Frequency	100kHz @ flowmeter Input (maximum frequency is 120kHz - 100kHz @ gate input overrange occurs at 100kHz)			
Inputs per Channel	2 - flowmeter input — used for all modes gate input — used in Totalizer and Nonresettable Totalizer modes			
Input Voltage	50mV-200V ac peak — Magnetic Pickup 5-40V dc (TTL compatible) Bently 3300 5 & 8 mm — Proximity Pickups			
Input Impedance	5K Ω \pm 30% resistive			
Number of Outputs	4			
Maximum Output Off-state Leakage Current	less than 300 μ A @ 40V dc			
Maximum On-state Voltage Drop	0.6 Ω x current			
Output Control	Any number of outputs are assignable to any of 4 channels. One "turn-on" value and one "turn-off" value per output.			
Output Voltage	5 to 40V dc, customer supplied			
Output Current	1A per channel sourced out of module All outputs can be on simultaneously without derating.			
Output Switching Time	outputs triggered by <i>Total</i> : turn ON < 100 μ s; turn OFF < 100 μ s all other turn ON and OFF times < 1ms			
Filtering (F0-F3 inputs) — jumper selectable	high-speed or low-pass filter jumper (filter = below 70Hz)			
Debouncing (G0-G3 inputs) — software selectable	1s (approximate) between transitions with no minimum pulse width — Totalizer and Nonresettable Totalizer modes only			
+24V dc Source	ripple: \pm 5%; noise: 240mV peak-to-peak			
Backplane Current	1A maximum			
Isolation Voltage	500V between input and backplane 1500V between output and backplane 500V between isolated channels 1500V between isolated outputs and gates			
Power Dissipation	13W (maximum); 2W (minimum)			
Thermal Dissipation	54.2 BTU/hr (maximum); 6.8 BTU/hr (minimum)			
Input Conductors	Wire Size Category Length	Belden 8761 Category 2 ¹ 304.8m (1000ft)		
Output Conductors	Wire Size Category	14 gauge stranded (maximum), 3/64 inch insulation (maximum) Category 1 ¹		
Environmental Conditions	Operating Temperature Storage Temperature Relative Humidity	0 to 60°C (32 to 140°F) -40 to 85°C (-40 to 185°F) 5 to 95% (without condensation)		
Field Wiring Arm	40-terminal (cat. no. 1771-WN)			
Wiring Arm Screw Torque	7-9 inch-pounds			
Keying (lower backplane connector)	between 2 and 4 between 6 and 8			
Use of Data Table	Image-input bits	Output-image bits	Read-block words	Write-block words
	8	8	41 max	60 max

¹ Use this conductor-category information for planning conductor routing as described in the system-level installation manual.



ALLEN-BRADLEY
A ROCKWELL INTERNATIONAL COMPANY

Allen-Bradley has been helping its customers improve productivity and quality for 90 years. A-B designs, manufactures and supports a broad range of control and automation products worldwide. They include logic processors, power and motion control devices, man-machine interfaces and sensors. Allen-Bradley is a subsidiary of Rockwell International, one of the world's leading technology companies.

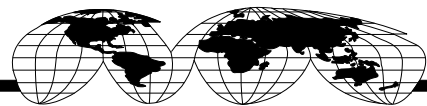

With major offices worldwide.

Algeria • Argentina • Australia • Austria • Bahrain • Belgium • Brazil • Bulgaria • Canada • Chile • China, PRC • Colombia • Costa Rica • Croatia • Cyprus • Czech Republic • Denmark • Ecuador • Egypt • El Salvador • Finland • France • Germany • Greece • Guatemala • Honduras • Hong Kong • Hungary • Iceland • India • Indonesia • Israel • Italy • Jamaica • Japan • Jordan • Korea • Kuwait • Lebanon • Malaysia • Mexico • New Zealand • Norway • Oman • Pakistan • Peru • Philippines • Poland • Portugal • Puerto Rico • Qatar • Romania • Russia-CIS • Saudi Arabia • Singapore • Slovakia • Slovenia • South Africa, Republic • Spain • Switzerland • Taiwan • Thailand • The Netherlands • Turkey • United Arab Emirates • United Kingdom • United States • Uruguay • Venezuela • Yugoslavia

World Headquarters, Allen-Bradley, 1201 South Second Street, Milwaukee, WI 53204 USA, Tel: (1) 414 382-2000 Fax: (1) 414 382-4444