



# Installation Instructions

## AC/DC (220V) Input Module Cat. No. 1771-IMD Series B

### To The Installer

This document provides information on:

- important pre-installation considerations
- power supply requirements
- initial handling
- installing the module
- using the indicators for troubleshooting
- module specifications

### Pre-installation Considerations

This module must be used with a 1771 B Series I/O chassis. If you are using a 1771-ASB remote I/O adapter you may use any combination of I/O modules. Otherwise, make sure no other input module or single card block transfer module is placed in the same I/O group.

This module contains input filtering to limit the effects of voltage transients caused by contact bounce and/or radiated electrical noise. The delay due to filtering is listed in the Specifications section.

### European Union Directive Compliance

If this product has the CE mark it is approved for installation within the European Union and EEA regions. It has been designed and tested to meet the following directives.

### EMC Directive

This product is tested to meet Council Directive 89/336/EEC Electromagnetic Compatibility (EMC) and the following standards, in whole or in part, documented in a technical construction file:

- EN 50081-2EMC – Generic Emission Standard, Part 2 – Industrial Environment
- EN 50082-2EMC – Generic Immunity Standard, Part 2 – Industrial Environment

This product is intended for use in an industrial environment.

# AB Spares

## Low Voltage Directive

This product is tested to meet Council Directive 73/23/EEC Low Voltage, by applying the safety requirements of EN 61131-2 Programmable Controllers, Part 2 – Equipment Requirements and Tests.

For specific information required by EN 61131-2, see the appropriate sections in this publication, as well as the following Allen-Bradley publications:

- Industrial Automation Wiring and Grounding Guidelines For Noise Immunity, publication 1770-4.1
- Guidelines for Handling Lithium Batteries, publication AG-5.4
- Automation Systems Catalog, publication B111

## Power Requirements

Your module receives its power through the 1771 I/O chassis backplane from the chassis power supply. The module requires 250mA from the output of this supply. Add this to the requirements of all other modules in the I/O chassis to prevent overloading the chassis backplane and/or chassis power supply.

## Initial Handling

The ac input module is shipped in a static-shielded bag to guard against electrostatic discharge damage. Observe the following precautions when handling the module.



**ATTENTION:** This module is equipped with a plastic cover that is unique to assembly numbers 960378-02 through 960378-09. (This part number is located near the backplane edge connector pins on the component-side of the circuit board.) Do not use this plastic cover on any other module.

---

## Electrostatic Discharge Damage



**ATTENTION:** Under some conditions, electrostatic discharge can degrade performance or damage the module. Observe the following precautions to guard against electrostatic damage.

---

- Wear an approved wrist strap grounding device, or touch a grounded object to discharge yourself before handling the module.
- Do not touch the backplane connector or connector pins.
- If you configure or replace internal components, do not touch other circuit components inside the module. If available, use a static-free work station.
- When not in use, keep the module in a static-shielded bag.

## Installing Your Module

In this section we tell you how to set the fault mode selection plug, key your I/O chassis, install your module and make your wiring connections.

### Fault Mode Selection

You may select one of two input-failure configurations (last state or reset) by positioning a configuration plug on the top edge of the printed circuit board. This configuration plug is independent of the last state switch on the I/O chassis backplane during a module fault. During a chassis fault, the I/O chassis backplane last state switch setting overrides the module fault mode selection plug.

To set the fault mode selection, proceed as follows:

1. Locate the fault mode selection plug at the top edge of the module circuit board.

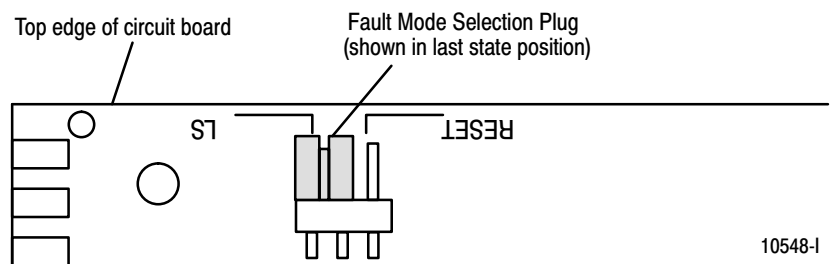

2. Using your finger, slide the plug off the 2 posts.
3. Carefully position the plug on 2 of the 3 posts that correspond to your requirement.

### Keying Your I/O Chassis

Use the plastic keying bands, shipped with each I/O chassis, to key the I/O slots to accept only this type of module.

The module circuit board is slotted in two places on the rear edge. The position of the keying bands on the backplane connector must correspond to these slots to allow insertion of the module. You can key any connector in an I/O chassis to receive this module except for the left-most connector reserved for adapter or processor modules. Place keying bands between the following numbers labeled on the backplane connector:

- Between 2 and 4
- Between 12 and 14

You can change the position of these keys if system redesign and rewiring makes insertion of a different module necessary.

AB Spares

## Installing the Input Module

To install the ac/dc input module in your 1771 I/O chassis, follow the steps listed below.



**ATTENTION:** Remove power from the 1771 I/O chassis backplane and field wiring arm before removing or installing an I/O module.

- Failure to remove power from the backplane or wiring arm could cause module damage, degradation of performance, or injury.
  - Failure to remove power from the backplane could cause injury or equipment damage due to possible unexpected operation.
- 

1. Turn off power to the I/O chassis.
2. Place the module in the plastic tracks on the top and bottom of the slot that guides the module into position.
3. Do not force the module into its backplane connector. Apply firm, even pressure on the module to seat it properly.
4. Snap the chassis latch over the top of the module to secure its position.
5. Connect the wiring arm to the module.
6. Make wiring connections to the field wiring arm as indicated in “Connecting Wiring to the Input Module.”

## Connecting Wiring to the Input Module

Connections to the input module are made to the 21 terminal field wiring arm (cat. no. 1771-WH) shipped with the module. Attach the wiring arm to the pivot bar on the bottom of the I/O chassis. The wiring arm pivots upward and connects with the module so you can install or remove the module without disconnecting the wires.

Connect one terminal of your 2-wire input devices to terminals 00 through 17.

### Connection Diagram for the 1771-IMD Module

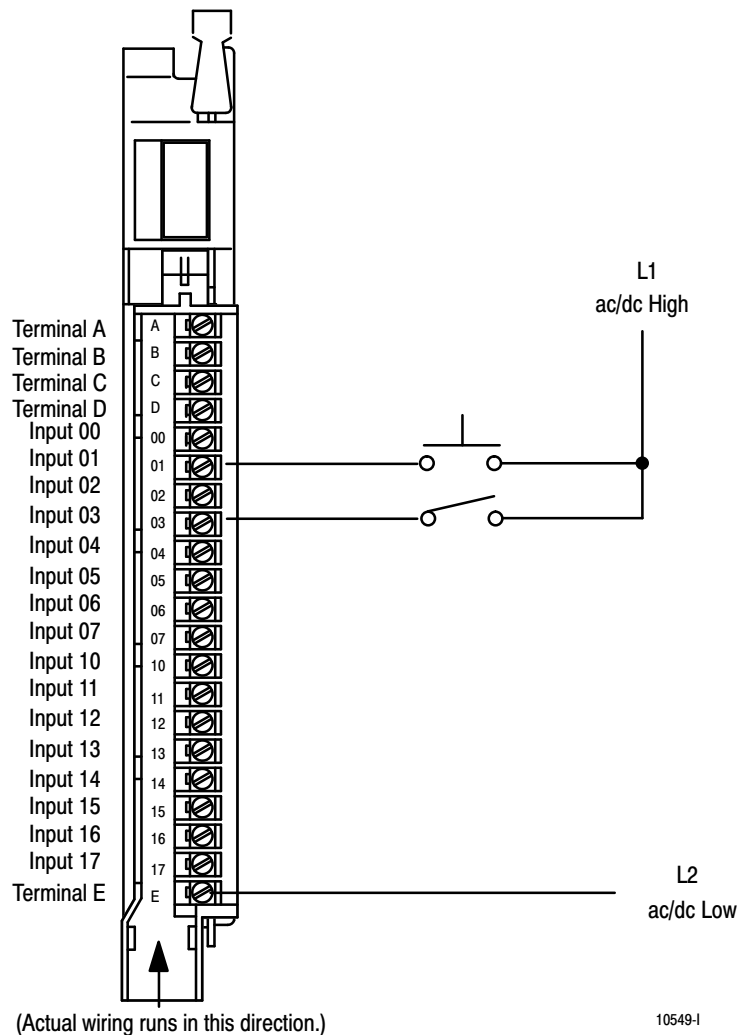

Connect terminal E to the L2 (low) ac/dc return. Terminals A through D are not used. Connect the L1 (high) ac/dc line to the other terminal of your input devices. Use stranded 14 or 16 gauge wire to minimize the voltage drop over long cable distances.

# AB Spares

**Important:** You can use an AC (220V) Output Module (cat. no. 1771-OMD) to directly drive terminals on an AC/DC (220V) Input Module (cat. no. 1771-IMD) as shown below.

You can also use a 1771-OM Output module to drive an AC/DC (220V) Input Module (cat. no. 1771-IMD) but you must connect a 10K ohm, 10W resistor between the output terminal and L2 (common) as shown below. **Use the same ac power source to power both modules to ensure proper phasing and prevent module damage.**

#### Driving a 1771-IMD Module with a 1771-OMD Module

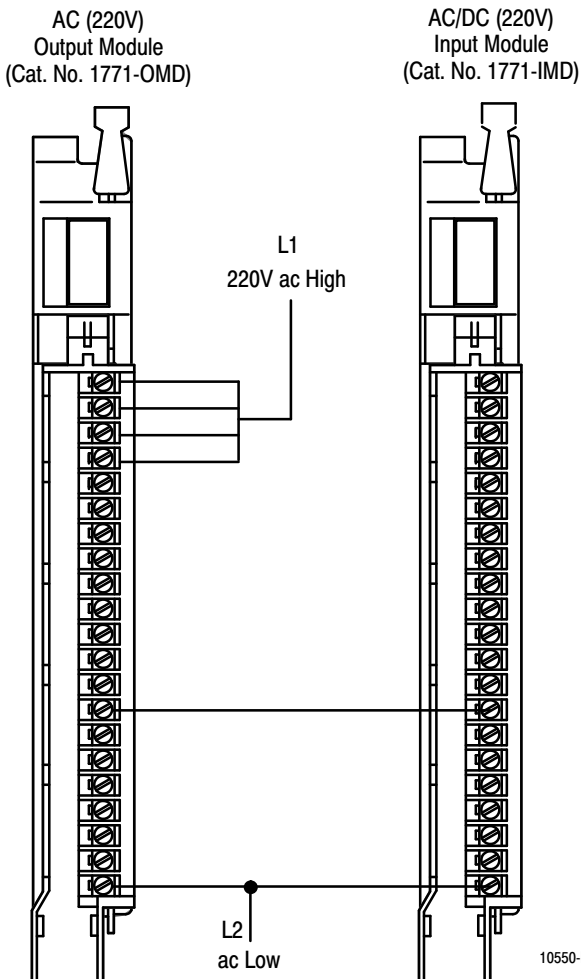

#### Driving an Input with an Output

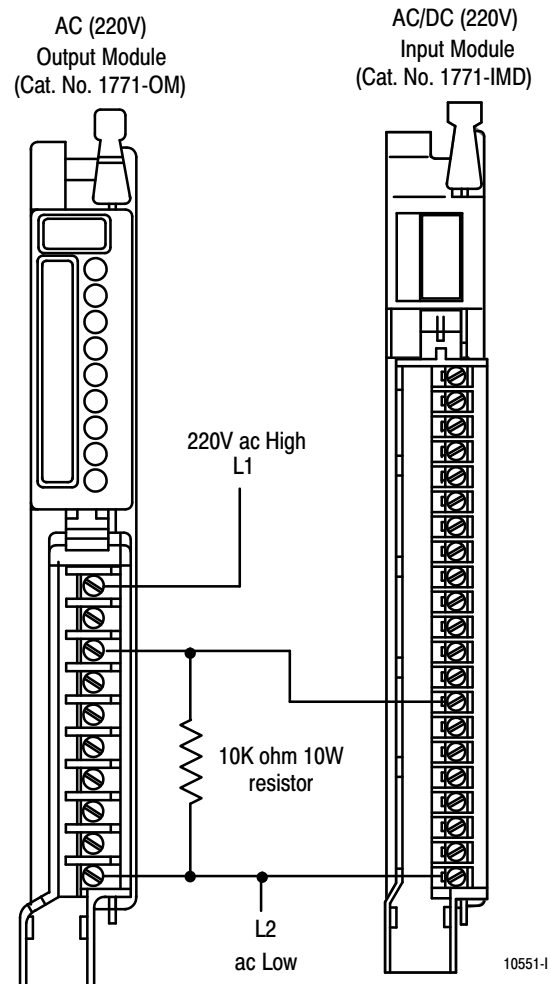

## Interpreting the Status Indicators

The front panel of your module contains one green, module active LED, and 16 red status LED indicators. The 1771-IMD performs diagnostics in a handshaking mode when first powered up. Upon successful completion of the diagnostics, the green module active indicator lights. It turns off if a fault occurs in the data paths or the opto-isolators.

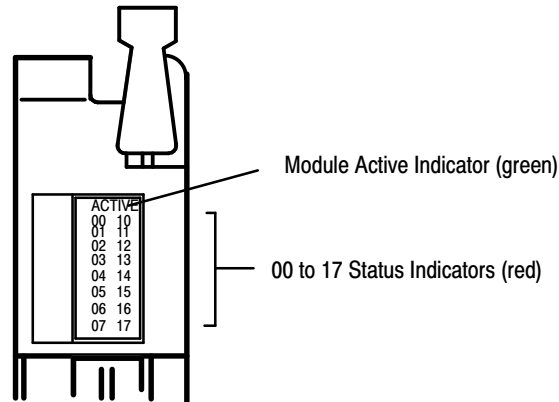

10552-I

If a module fault occurs, the module resets its inputs or sets them to last state, depending on the fault mode selection. The module active indicator must be on to properly interpret the red status indicators.

The red status indicators are provided for system logic side indication of individual inputs. When a red indicator lights, voltage is present on the terminal. The module transfers this information to the backplane for the processor to read. See "Troubleshooting" for a description, probable cause, and recommended action to take for common faults based on indicator responses.

## Troubleshooting

Use this table to help you interpret the 1771-IMD status indicators and to troubleshoot module and system faults.

Indicator Status (color)	Description of Fault or System Status	Action to Take
Module active ON (green)	Normal Indication	None
Module active ON (green) and Input status ON (red)	Check for voltage on terminal	If none, replace module
Module active ON (green) and Input status OFF	Input devices not functioning properly or faulty input circuitry on module	1. Check input devices 2. If input devices are OK, replace module
	No voltage on terminal	None
Module active OFF	Module is not powered or fault in opto-isolators and/or data paths; module resets inputs or goes to last state	1. Check chassis power supply and module input power 2. If power supplies are OK, replace module
Module active OFF and Input status ON (red) or OFF	Not valid unless module active indicator is on; when active is off, indicators do not represent processor status	1. Check chassis power supply and module input power 2. If power supplies are OK, replace module

AB Spares

## Specifications

Inputs per Module	16
Module Location	1771-A1B, -A2B, -A3B, -A3B1, -A4B or later I/O chassis
Nominal Input Voltage	220V ac @ 50/60Hz; 220V dc
Nominal Input Current	10.4mA @ 220V ac 60Hz; 9.9mA @ 220V ac 50Hz 0.6mA @ 220V dc
On-state Voltage Range	184V to 250V ac 166V to 230V dc
Minimum On-state Current	8.7mA at 184V ac, 50Hz 0.43mA at 166V dc
Maximum Off-state Voltage	92V ac or dc
Maximum Off-state Current	3mA at 92V ac, 60Hz 0.25mA at 92V dc
Input Impedance	0.15 $\mu$ F (21.2K at 50Hz) in parallel with 370K; in series with 1K ohm
Peak Inrush Current	$V_{PS}/1K$ ohm, where $V_{PS}$ = customer supply peak voltage
Input Signal Delay	Off to on: 15+8ms for ac or dc On to off: 172+56ms for ac or dc
Power Dissipation	5.8 Watts (max.), 1.3 Watts (min.)
Thermal Dissipation	19.8 BTU/hr (max.), 4.5 BTU/hr (min.)
Backplane Current	250mA @ 5V dc
Isolation Voltage	Isolation meets or exceeds UL Standard 508, and CSA Standard C22.2 No. 142.
Environmental Conditions	
Operational Temperature	0° to 60°C (32° to 140°F)
Storage Temperature	-40° to 85°C (-40° to 185°F)
Relative Humidity	5 to 95% (without condensation)
Conductors	
Wire Size	14 gauge stranded maximum 3/64 inch insulation maximum
Category	1 <sup>1</sup>
Keying	Between 2 and 4 Between 12 and 14
Field Wiring Arm	Catalog Number 1771-WH
Wiring Arm Screw Torque	7-9 inch-pounds
Agency Certification (when product or packaging is marked)	<ul style="list-style-type: none"> <li>• CSA certified</li> <li>• CSA Class I, Division 2, Groups A, B, C, D certified</li> <li>• UL listed</li> <li>• CE marked for all applicable directives</li> </ul>

<sup>1</sup> Refer to publication 1770-4.1, Programmable Controller Wiring and Grounding Guidelines.



Allen-Bradley, a Rockwell Automation Business, has been helping its customers improve productivity and quality for more than 90 years. We design, manufacture and support a broad range of automation products worldwide. They include logic processors, power and motion control devices, operator interfaces, sensors and a variety of software. Rockwell is one of the world's leading technology companies.



### Worldwide representation.

Argentina • Australia • Austria • Bahrain • Belgium • Brazil • Bulgaria • Canada • Chile • China, PRC • Colombia • Costa Rica • Croatia • Cyprus • Czech Republic • Denmark • Ecuador • Egypt • El Salvador • Finland • France • Germany • Greece • Guatemala • Honduras • Hong Kong • Hungary • Iceland • India • Indonesia • Ireland • Israel • Italy • Jamaica • Japan • Jordan • Korea • Kuwait • Lebanon • Malaysia • Mexico • Netherlands • New Zealand • Norway • Pakistan • Peru • Philippines • Poland • Portugal • Puerto Rico • Qatar • Romania • Russia-CIS • Saudi Arabia • Singapore • Slovakia • Slovenia • South Africa, Republic • Spain • Sweden • Switzerland • Taiwan • Thailand • Turkey • United Arab Emirates • United Kingdom • United States • Uruguay • Venezuela • Yugoslavia

Allen-Bradley Headquarters, 1201 South Second Street, Milwaukee, WI 53204 USA, Tel: (1) 414 382-2000 Fax: (1) 414 382-4444