

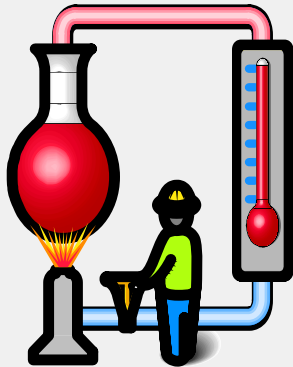

**Allen-Bradley**

***Temperature  
Control Module***

***(Cat. No. 1771-TCM  
Configuration Software  
Release 1.0)***



**TemperatureControl™**  
*1771 Configurator*

# Programming Manual

AB Drives

## Important User Information

Because of the variety of uses for the products described in this publication, those responsible for the application and use of this control equipment must satisfy themselves that all necessary steps have been taken to assure that each application and use meets all performance and safety requirements, including any applicable laws, regulations, codes and standards.

The illustrations, charts, sample programs and layout examples shown in this guide are intended solely for purposes of example. Since there are many variables and requirements associated with any particular installation, Allen-Bradley does not assume responsibility or liability (to include intellectual property liability) for actual use based upon the examples shown in this publication.

Allen-Bradley publication SGI-1.1, *Safety Guidelines for the Application, Installation, and Maintenance of Solid-State Control* (available from your local Allen-Bradley office), describes some important differences between solid-state equipment and electromechanical devices that should be taken into consideration when applying products such as those described in this publication.

Reproduction of the contents of this copyrighted publication, in whole or in part, without written permission of Allen-Bradley Company, Inc., is prohibited.

Throughout this manual we use notes to make you aware of safety considerations:



**ATTENTION:** Identifies information about practices or circumstances that can lead to personal injury or death, property damage or economic loss.

---

Attention statements help you to:

- identify a hazard
- avoid the hazard
- recognize the consequences

**Important:** Identifies information that is critical for successful application and understanding of the product.

# Table of Contents

---

<b>Using this Manual</b> .....	<b><a href="#">P-1</a></b>
Who Should Use this Manual .....	<a href="#">P-1</a>
Conventions Used in this Manual .....	<a href="#">P-1</a>
Terms and Abbreviations .....	<a href="#">P-2</a>
Related Publications .....	<a href="#">P-2</a>
<b>Interfacing with the Temperature Control Module</b> .....	<b><a href="#">1-1</a></b>
How the Temperature Control Module Configuration Software Interacts with the PLC Processor and the Temperature Control Module ..	<a href="#">1-1</a>
Sample Ladder Logic .....	<a href="#">1-1</a>
Using the Sample Ladder Logic Program .....	<a href="#">1-2</a>
How the Temperature Control Module Communicates with PLC Processors .....	<a href="#">1-2</a>
How the Temperature Control Software Interfaces with PLC Processors .....	<a href="#">1-3</a>
Data-Table Interface Area .....	<a href="#">1-4</a>
Communication Control Bits .....	<a href="#">1-6</a>
What to do next .....	<a href="#">1-6</a>
<b>Installing the Software</b> .....	<b><a href="#">2-1</a></b>
Requirements for Your Computer .....	<a href="#">2-1</a>
Preparation for Installing the Software .....	<a href="#">2-2</a>
Convention .....	<a href="#">2-2</a>
Installation Procedure .....	<a href="#">2-2</a>
Starting the Software .....	<a href="#">2-9</a>
Using Online Help .....	<a href="#">2-10</a>
What to do next .....	<a href="#">2-10</a>
<b>Organizing the Project File</b> .....	<b><a href="#">3-1</a></b>
The Temperature Control Project File .....	<a href="#">3-1</a>
Creating a Project File .....	<a href="#">3-1</a>
Adding Modules to the Project File .....	<a href="#">3-3</a>
Modifying an Existing Module .....	<a href="#">3-4</a>
What to do next .....	<a href="#">3-4</a>
<b>Configuring the Modules</b> .....	<b><a href="#">4-1</a></b>
Configuration Selections .....	<a href="#">4-1</a>
Uploading and Downloading Information .....	<a href="#">4-1</a>
Accessing the Module Configuration Screen .....	<a href="#">4-2</a>
Downloading Configuration Values .....	<a href="#">4-4</a>
Uploading Configuration Values .....	<a href="#">4-5</a>

Module Description .....	<a href="#">4-6</a>
Copying Configuration Values From One Module to Another .....	<a href="#">4-6</a>
Copying Configuration Values From One Module Into a New Module .....	<a href="#">4-7</a>
Moving a Module From One Project to Another .....	<a href="#">4-8</a>
What to do next .....	<a href="#">4-8</a>
<b>Configuring the Loops .....</b>	<b><a href="#">5-1</a></b>
Changing Default Loop Names .....	<a href="#">5-1</a>
Configuration Selections .....	<a href="#">5-2</a>
Open-Circuit Detection .....	<a href="#">5-2</a>
Barrel/Non-Barrel Control .....	<a href="#">5-3</a>
Switch to Barrel Control? .....	<a href="#">5-3</a>
Inner/Outer Zone .....	<a href="#">5-4</a>
Thermal Integrity Loss Detection .....	<a href="#">5-4</a>
Alarms .....	<a href="#">5-5</a>
Alarm Dead Band .....	<a href="#">5-6</a>
TPO Bit .....	<a href="#">5-6</a>
Accessing the Loop Configuration Screen .....	<a href="#">5-7</a>
Entering Loop Configuration Values .....	<a href="#">5-8</a>
Downloading Configuration Values .....	<a href="#">5-10</a>
Uploading Configuration Values .....	<a href="#">5-11</a>
Using One Loop to Configure Another .....	<a href="#">5-12</a>
Loop Description .....	<a href="#">5-13</a>
What to do next .....	<a href="#">5-13</a>
<b>Tuning the Loops .....</b>	<b><a href="#">6-1</a></b>
Introduction to Loop Tuning .....	<a href="#">6-1</a>
The Auto-Tuning-Process .....	<a href="#">6-1</a>
Preparing to Auto-Tune Loops .....	<a href="#">6-1</a>
Tuning Parameters .....	<a href="#">6-2</a>
Configuring Tuning Parameters .....	<a href="#">6-3</a>
Auto-Tuning the Loops .....	<a href="#">6-4</a>
Auto-Tuning Procedure .....	<a href="#">6-4</a>
Monitoring Auto-Tuning Results .....	<a href="#">6-5</a>
Downloading Tuning Results .....	<a href="#">6-6</a>
Fine-Tuning the Loops .....	<a href="#">6-6</a>
Fine-Tuning Procedure .....	<a href="#">6-7</a>
Changing the System Response Setting After Tuning is Complete ..	<a href="#">6-8</a>
What to do next .....	<a href="#">6-8</a>

---

<b>Monitoring and Controlling the Loops</b> .....	<b><a href="#">7-1</a></b>
Loop Monitor Screen .....	<a href="#">7-1</a>
Changing Loop Settings .....	<a href="#">7-3</a>
Entering Loop Settings .....	<a href="#">7-3</a>
To Cancel .....	<a href="#">7-4</a>
To Download .....	<a href="#">7-4</a>
Module Monitor Screen .....	<a href="#">7-4</a>
<b>Documenting Projects, Modules, and Loops</b> .....	<b><a href="#">8-1</a></b>
Reports .....	<a href="#">8-1</a>
Printing or Viewing an Entire Project .....	<a href="#">8-1</a>
Printing a Single Module or Loop .....	<a href="#">8-2</a>

# Using this Manual

This manual describes the use of Temperature Control™ configuration software for use with the Temperature Control module (1771-TCM, series C). For information on how to install the module or how to generate the necessary ladder-logic programming for operating the module with this configuration software, see publication 1771-6.5.120. This ladder logic is provided with your Temperature Control configuration software as well.

## Who Should Use this Manual

Use this manual if you are responsible for installing the Temperature Control software, or using it to configure, tune, or operate the temperature control loops. You must be able to program and operate an Allen-Bradley programmable controller to make efficient use of your Temperature Control module. In particular, you must know how to program block-transfer instructions. If you do not, refer to the appropriate PLC® programming manual before you attempt to generate a program for this module.

## Conventions Used in this Manual

The following conventions are used throughout this manual:

- User prompts are shown in fixed-pitch type:

`c:\`

- Text that you enter literally is shown in bold fixed-pitch type:

**`a:\setup`**

- A literal key stroke that can not be represented by a single character is shown in bold type inside a box:

**win** 

- Items displayed only on the screen are shown in plain type:

In the **Name** field, enter . . .

- Items on the screen that we tell you to select are shown in plain bold type:

From the **Module** menu, select **Download**.



We also use this convention to call attention to helpful information.

## Terms and Abbreviations

For a complete listing of Allen–Bradley terminology, refer to the *Allen-Bradley Industrial Automation Glossary* (publication AG-7.1). In this manual, we refer to:

- the Temperature Control module as the “1771-TCM module,” the “TCM module,” or as the “module”
- the Temperature Control Module Configuration Software as “configuration software” or “software”
- the programmable controller processor, as the “PLC processor” or the “processor”
- a thermocouple as a “TC”
- a time-proportioned output as a “TPO”
- a temperature control PID loop as a “temperature control loop,” a “PID loop,” or a “loop”

In addition, some terminology has been adjusted to conform to ISA/IEEE standard definitions. The table below shows the commonly-used Allen-Bradley terms that you may already be accustomed to, the corresponding ISA/IEEE terms, and the definitions for these words.

Existing A-B Term	ISA/IEEE Term	Definition
Control Variable (V or CV) or Controller Output (CO)	Manipulated Variable (M)	A quantity or condition which the controller applies to the controlled system
Process Variable (PV)	Controlled Variable (C)	In a control loop, the quantity or condition of the controlled system which is directly measured and controlled
	Process Variable (PV)	Any variable of the process, including the manipulated variable and the controlled variable
Proportional Gain ( $K_p$ )	Controller Gain ( $K_c$ )	The overall gain for the loop with dependent PID control action; this affects the integral and derivative terms as well as the proportional term

## Related Publications

For a list of publications with information on Allen-Bradley programmable controller products, consult our Publication Index (publication SD499).

For information on how to install the module or how to generate the necessary ladder-logic programming for operating the module with this configuration software, refer to the Temperature Control Module User Manual, publication 1771-6.5.120.

# AB Drives

## Interfacing with the Temperature Control Module

This chapter describes how to interface the Temperature Control module through the PLC processor to the configuration software. This includes:

- how the Temperature Control module configuration software interacts with the PLC processor and the Temperature Control module
- sample ladder logic (utility ladder logic provided)
- using the sample ladder logic program
- how the Temperature Control module communicates with the PLC processor
- how the Temperature Control software interfaces with PLC processors
- block-transfer programming
- data-table interface area
- communication control bits

### How the Temperature Control Module Configuration Software Interacts with the PLC Processor and the Temperature Control Module

The Temperature Control module configuration software provides easy-to-use screens to help you configure, tune, and operate temperature control modules. The configuration software does not communicate or transfer data directly with the module. Instead, the software reads data from and writes data into an area of the PLC's data table, called the data table block. If you have multiple modules, each must have a separate data table block.

The utility ladder logic running on the PLC processor then transfers this data to or from the module using block transfer instructions. You can select the area of the data table to be used by the software, but the arrangement of the data within the data table block is fixed by this software.

### Sample Ladder Logic

Utility ladder logic is provided with the configuration software. We recommend that you use this utility ladder logic, since it contains all the necessary block transfers and control instructions needed to use the configuration software with the Temperature Control module, and has been tested to operate correctly with both the module and the software.



The sample ladder logic can be combined with the other logic you need for your application. If you prefer to write your own ladder logic, it must duplicate the arrangement of data within the block and the operation of the control bits that the sample logic uses in order for the configuration software to operate correctly.

## Using the Sample Ladder Logic Program

During installation of the configuration software, you will have the option of copying the sample ladder logic to your computer. From there, you can restore the program to your processor using your PLC programming software. You then edit the subroutine in the sample ladder logic so that the block transfer instructions address the correct rack, group, and slot for your module. You also edit the subroutine to use your desired data table block address.

If you have multiple modules, you make a copy of the subroutine for each module, and then edit the copies as described above. Refer to Appendix C of the Temperature Control Module User Manual (publication 1771-6.5.120) for detailed instructions on editing the sample ladder logic.

## How the Temperature Control Module Communicates with PLC Processors

The Temperature Control module communicates with the PLC processor by both block-transfer and single-transfer. The ladder logic must include block-transfer write instructions to send the following data blocks to the module:

- a configuration block for each PID loop (8 max)
- gains block
- auto-tune block
- dynamic block
- calibration block (not required for normal operation)

The ladder logic must include block-transfer read instructions to get the following data blocks from the module:

- system status
- gains block
- auto-tune block
- calibration block (not required for normal operation)

Unless the 1771-TCM module is located in a remote I/O chassis, you can provide high-speed processing of time-proportioned output (TPO) signals by including instructions in the ladder logic for dealing with an input image byte single-transferred from the module. This byte contains the control-variable output of each loop as the duty cycle of a bit that is cycled at a regular period. Each bit represents one of the 8 PID loops.

# AB Drives

The following graphic illustrates how the individual data blocks are sent to and returned from the TCM module.

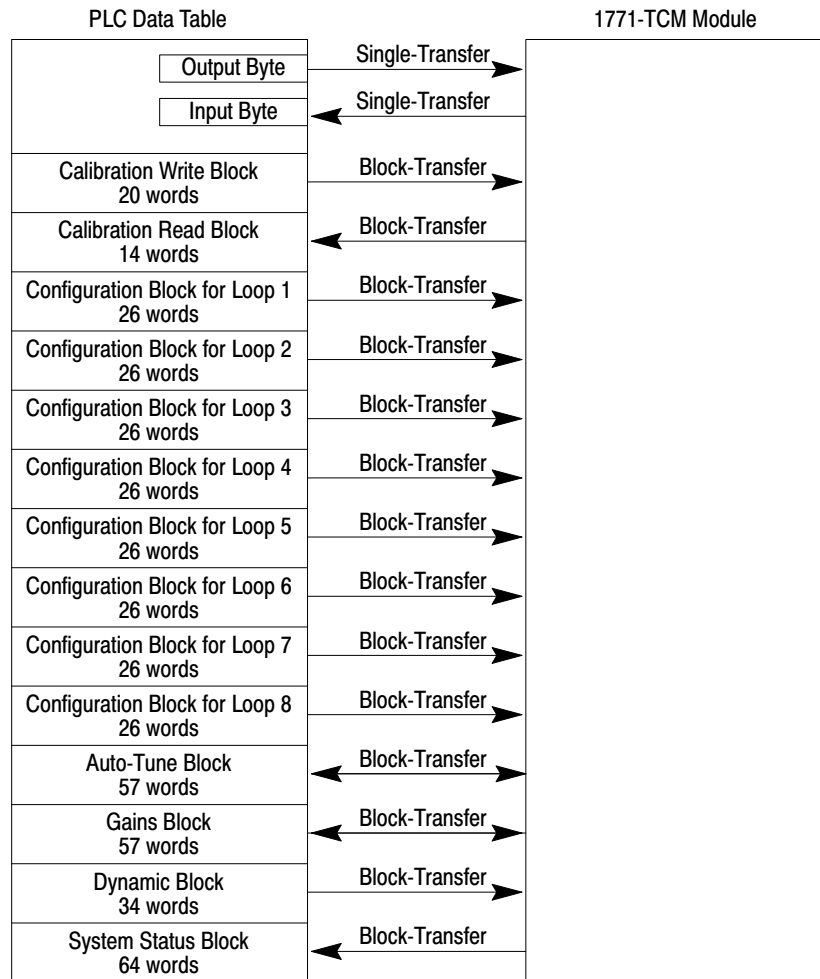

## How the Temperature Control Software Interfaces with PLC Processors

The computer with the Temperature Control software communicates with the PLC processor across a local DH+ link or a DF1 serial link.

**Important:** For configuring temperature control loops, you can not have the computer on one DH+ link and have the PLC processor on another (remote) DH+ link even if they are in the same DH+ network.

As shown in the following graphic, after entering configuration selections at the computer, you can download them to disk files and/or the PLC processor's data-table interface area for use by the module. Later, you can upload configuration selections from either the disk files or the PLC processor's data-table interface area for making changes.

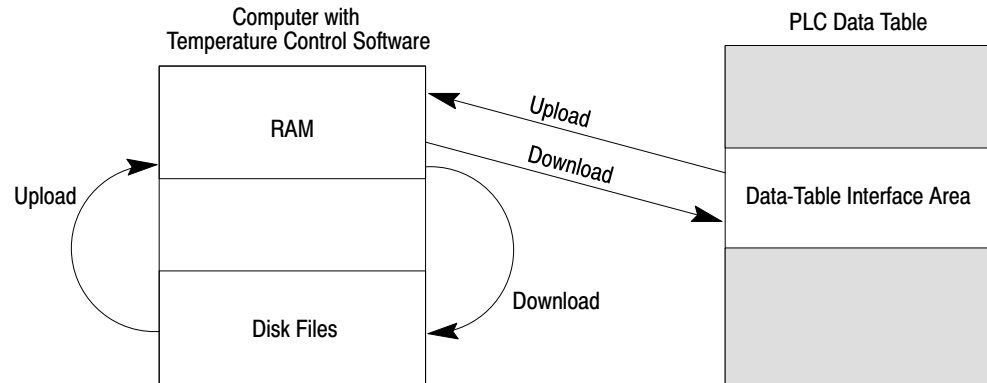

For information on block-transfer programming, refer to your Temperature Control Module User Manual (publication 1771-6.5.120)

## Data-Table Interface Area

To use the Temperature Control configuration software, the read and write blocks, along with a control word, must be organized into a 614-word data-table interface area in an integer file with the word offsets shown below. The utility ladder logic provides this.

Word Offset	Description
0	Communication control word (initiates block-transfer of configuration auto-tune, or gains values when you set a specific bit)
1	Used by the example ladder logic as: BT identity bits
2	Used by the example ladder logic as: BT check mask
3	Used by the example ladder logic as: Cycle sequence number
4	Used by the example ladder logic as: Loop offset value
5	Used by the example ladder logic as: Data-table file offset
6	Not used by the example ladder logic
7	Not used by the example ladder logic
8	Not used by the example ladder logic
9	Used by the example ladder logic as: TPO bits — single-transferred
10 – 39	Loop-1 configuration block (26 words)
40 – 69	Loop-2 configuration block (26 words)
70 – 99	Loop-3 configuration block (26 words)
100 – 129	Loop-4 configuration block (26 words)
130 – 159	Loop-5 configuration block (26 words)
160 – 189	Loop-6 configuration block (26 words)
190 – 219	Loop-7 configuration block (26 words)
220 – 249	Loop-8 configuration block (26 words)
250 – 309	Gains block (57 words)
310 – 349	Dynamic block (34 words)
350 – 419	Status block (64 words)
420 – 479	Auto-tune block (system ID data) (57 words)
480 – 549	Scratch-pad area addressed by the block-transfer write instruction (64 words)
550 – 613	Scratch-pad area addressed by the block-transfer read instruction (64 words)

To establish a TCM project file, you must enter the starting address of this interface area for each Temperature Control module. (See Chapter 4 for more information.) The example ladder logic in Appendix C of the Temperature Control Module User Manual (publication 1771-6.5.120) uses N7:0 as the starting address for this interface area. To keep things simple, we recommend using word 0 of a file as the starting address. However, as long as you provide the indicated word offsets, the interface area can start with any word in an integer file. If you install multiple Temperature Control modules in your PLC system, you will need to assign a separate integer file for each of them so that only one uses file N7. You will have to make the corresponding address changes for each additional module.

Note that no areas are designated for calibration read or write blocks. Calibration is an off-line function that the Temperature Control software does not handle.

For details on how the example ladder logic program uses words 1 through 5 and 9, refer to appendix C of the Temperature Control Module User Manual (publication 1771-6.5.120). Your ladder logic program does not have to use words 1 through 9 in the same way as in the example ladder logic program. However, you must use words 0 and 10 through 614 exactly as indicated.

## Communication Control Bits

The configuration software uses word 0 to control the communications between the PLC processor and the module. Bits 0 through 11 of word 0 of the data-table interface area are communication control bits. Based on your input to the Temperature Control software, bits 0 through 11 will be used to initiate a corresponding block-transfer. Your ladder logic program must respond to this input by generating the required block-transfer. Bits 14 and 15 are used internal to the example program.

Word Offset	Bit	Description
0	0	Loop-1 configuration block write to TCM required
	1	Loop-2 configuration block write to TCM required
	2	Loop-3 configuration block write to TCM required
	3	Loop-4 configuration block write to TCM required
	4	Loop-5 configuration block write to TCM required
	5	Loop-6 configuration block write to TCM required
	6	Loop-7 configuration block write to TCM required
	7	Loop-8 configuration block write to TCM required
	8	Auto-tune (system ID data) block write to TCM required
	9	Auto-tune (system ID data) block read from TCM required
	10	Gains block write to TCM required
	11	Gains block read from TCM required
	12	not used
	13	not used
	14	Used by the example ladder logic as: A manual download requested but no block-transfer in progress
15	Used by the example ladder logic as: Block-transfer to/from TCM in progress	

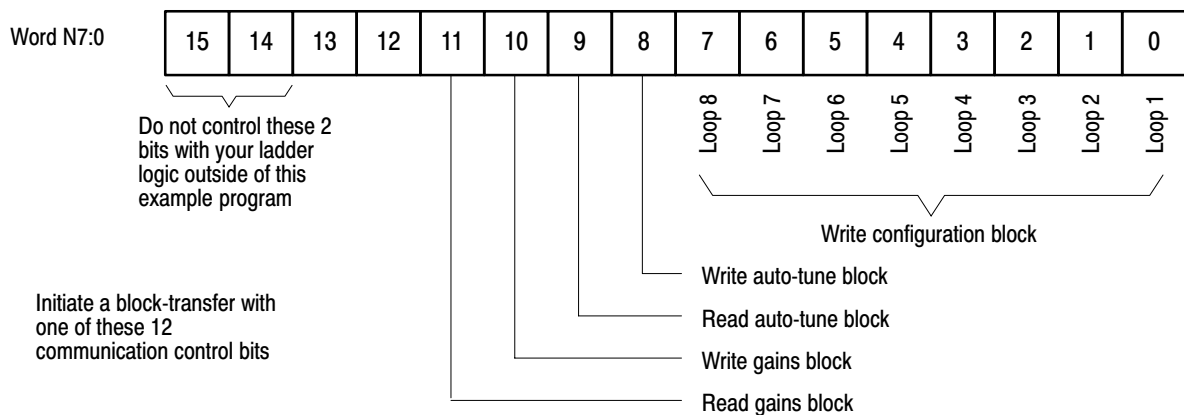

## What to do next

To learn how to install the Temperature Control configuration software, read chapter 2

# AB Drives

## Installing the Software

This chapter shows you how to install the TemperatureControl configuration software for the 1771-TCM module. This includes:

- requirements for your computer
- preparation for installing the software
- installation procedure
- starting the software
- using online help

### Requirements for Your Computer

To use the TemperatureControl configuration software, your system must meet these requirements:

#### Hardware

- computer with an 80386 or greater microprocessor (80486 or Pentium recommended)
- at least 12 Mbytes of RAM
- hard drive with adequate free disk space (12 Mbytes or greater)
- 1.44 Mbyte floppy disk drive (for installing the software)
- VGA™ or higher-resolution adapter/monitor with small fonts. We support 640x480, 800x600, 1024x786 modes. We recommend a Super VGA resolution adapter/monitor.
- mouse
- DH+ port (on KT- or KL-type module) or standard serial port

#### Connection

- If you connect to the PLC processor through a DH+ port, the computer and the PLC processor must be on the same DH+ link

#### Software

- MS-DOS® v5.0 or later
- Microsoft Windows v3.1 or v3.11, Windows for Workgroups 3.11, or Windows 95  
If you are using Windows 3.1 or 3.11, we recommend a permanent swap file of at least 10 Mbytes.
- TemperatureControl Configuration software
- INTERCHANGE
- Win32s if you are using Windows 3.1, 3.11, or Windows for Workgroups 3.11

## Preparation for Installing the Software

The Temperature Control configuration software includes three sets of disks:

This set:	Installs:
1 (3 disks)	The configuration software itself
2 (2 disks)	Win32s software (Windows 3.1 or 3.11 only)
3 (2 disks)	INTERCHANGE software



### Getting help while installing TemperatureControl software

- Press **F1** to display installation help.
- Click on **Cancel** to abort the installation. You can run the installation setup a second time to complete an aborted installation (see page 2-2).
- If a serious error occurs during the installation, view the text file `INSTALL.LOG` in your root directory. This file may help you figure out what the problem is.

### Convention



These instructions assume the 3½-inch disk is to be inserted into drive **a:** of your computer. If drive **a:** is not used, replace the **a:** in these instructions with the appropriate drive designation.

## Installation Procedure

To install the TemperatureControl configuration software, follow these steps:

1. In the Windows Program Manager, from the File pull-down menu, select Run.

The Run dialog box appears.

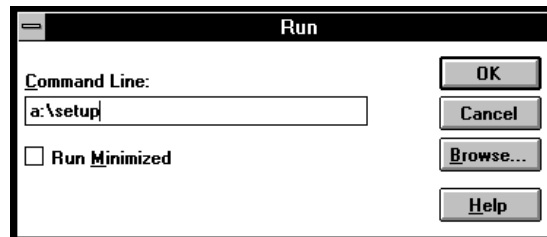

# AB Drives

2. Insert disk 1 of the Configuration Software into drive **a:**.
3. On the command line, type: **a:\setup**
4. Click on **OK**.

The software initialization screen appears, as well as a completion percentage graph that indicates initialization status. Once initialization is complete, the Welcome screen appears.



5. Click on the **Next** button to continue with the installation.

A prompt appears, asking you if you wish to read the readme file.

### ▶ Viewing the Readme file

Any last-minute changes or additions to these instructions are described in a Readme file. If this file is present, a prompt appears:

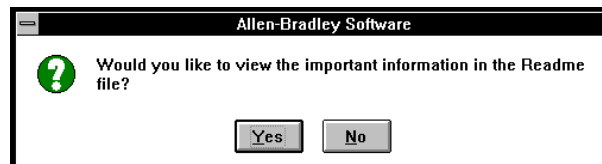

We recommend that you select **Yes**. If you do, the installation resumes after you have viewed the Readme file. You can also view the file later by selecting its icon from the Allen-Bradley program group. If you do choose **No**, the installation continues immediately.

You are prompted to enter disk 2.



6. Insert disk 2 of the Configuration Software into drive **a:** and click on **OK**.

The Choose Destination Location screen appears.

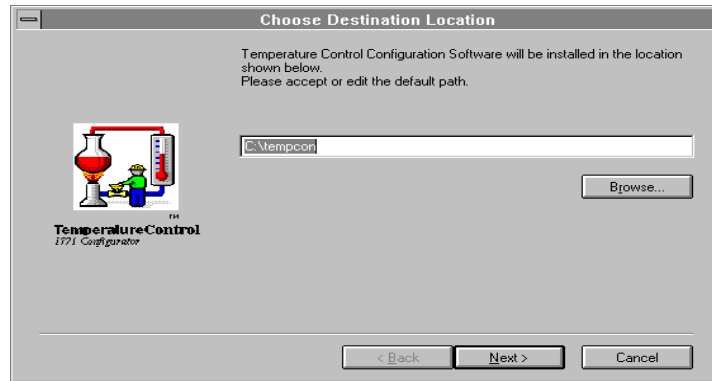

7. Either enter a new destination where you would like the TCM software to be installed, or click on the **Next** button to accept the default directory.

If the directory does not already exist, you are prompted to decide whether you want to create it. Choose **Yes** if you want the system to create the directory.

The software installation continues and the percentage graph displays installation status.

You are prompted to enter disk 3.

8. Insert disk 3 into drive **a:** and click on **OK**.

The installation continues.

You are prompted to decide whether you want to install the ladder logic utility programs. If you choose **Yes**, the Select Components screen appears.



# AB Drives

- Click on the **Next** button.

The Choose Destination Location screen appears.

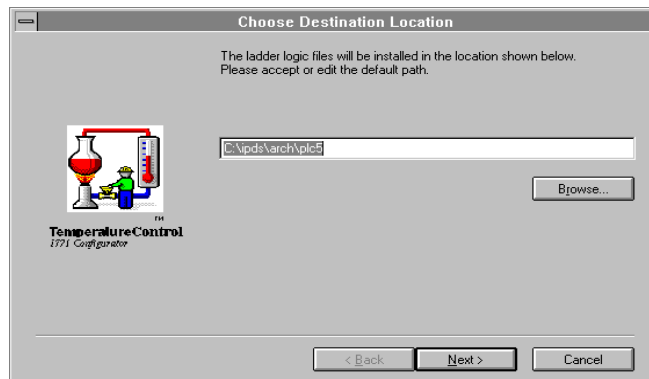

- Either enter a new destination where you would like the ladder logic files to be installed, or click on the **Next** button to accept the default directory.

If the directory does not already exist, you are prompted to decide whether you want to create it. Choose **Yes** if you want the system to create the directory. The system then installs the files.

If you are using Windows 3.1 or 3.11, you are prompted to enter disk 1 of the WIN32s files. If you are using Windows 95, proceed with step 13.

- Insert disk 1 of the WIN32s files into drive **a:** and click on **OK**.

The installation continues.



### Installing the Win32s files

If Win32s files already exist, the system compares the version number of the existing copy to that of the new copy:

- If the existing copy is older, the prompt will indicate that the software may not work properly with the old version, and ask whether to overwrite or leave the existing copy
- If the existing copy is the same or newer, you will still be prompted to either overwrite or leave the existing copy

You are prompted to enter disk 2 of the WIN32s files

- Insert disk 2 of the WIN32s files into drive **a:** and click on **OK**.

As the system copies the Win32s files, it displays a completion-percentage graph.

Once these files are installed, you are prompted to enter disk 1 of the INTERCHANGE software.

**13.** Insert disk 1 of the INTERCHANGE software into drive **a:** and click on **OK**.



### Existing INTERCHANGE software

If the current version of INTERCHANGE software already exists on the computer, you are asked whether to reinstall the software.

As the system copies the INTERCHANGE files from disk 1, it displays a completion percentage graph.

When the system has copied the files from disk 1, you are prompted to insert disk 2:

**14.** Insert disk 3 of the INTERCHANGE software into drive **a:** and click on **OK**.

Once the system has copied the remainder of the INTERCHANGE files, a prompt appears, giving you choices about modifying your AUTOEXEC.BAT file.

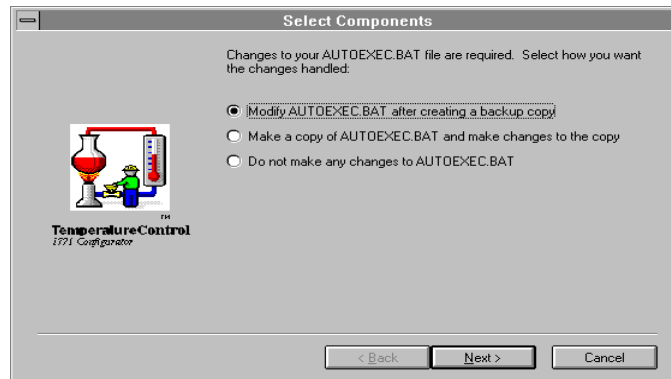

# AB Drives

**15.**In this dialog box:

If you select:	Then:
Modify AUTOEXEC.BAT after creating a backup copy. (Note: This is the recommended choice.)	<ul style="list-style-type: none"> <li>•the system asks if you want to modify your AUTOEXEC.BAT file so that it automatically loads INTERCHANGE software. If you select <b>No</b> at that prompt, you must manually start INTERCHANGE software *</li> <li>•the system makes a backup copy of your AUTOEXEC.BAT file and modifies the original</li> </ul>
Make a backup copy of AUTOEXEC.BAT and make changes to the copy.	<ul style="list-style-type: none"> <li>•the system asks if you want to modify your AUTOEXEC.BAT file so that it automatically loads INTERCHANGE software. If you select <b>No</b> at that prompt, you must manually start INTERCHANGE software *</li> <li>•the system will modify a copy of your AUTOEXEC.BAT file. You must then examine the copy and make the appropriate changes to your actual AUTOEXEC.BAT file. The software will not operate properly until you edit your actual AUTOEXEC.BAT file</li> </ul>
Do not make any changes to AUTOEXEC.BAT.	no changes will be made to your AUTOEXEC.BAT file. * The software will not operate properly until you edit the AUTOEXEC.BAT file. Detailed instructions on editing this file are in the INTERCHANGE software user manual (publication 5000-6.6.6).

\* If you select in either of these three cases to not make any changes to the AUTOEXEC.BAT file, you must first start INTERCHANGE software before you start Windows.



You are prompted to decide whether you want the AUTOEXEC.BAT file modified so that it will automatically load when you start your computer. You are also reminded to reboot your system to make the changes take effect.

The system then prompts you with this dialog box:

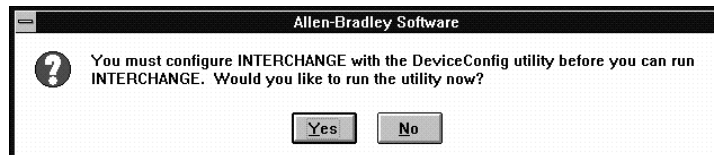
**Note:** If INTERCHANGE is already installed and configured, you will not see this dialog box.

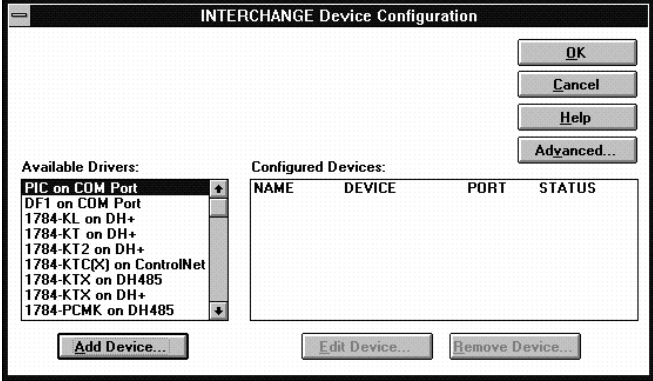

16. In this dialog box:

If you select:	Then:
<p><b>Yes</b></p>	<p>the system alerts you that installation will resume after you have completed device configuration. Click on <b>OK</b>. You see:</p>  <p>Refer to the <i>Device Configuration Utility User Manual</i>, publication 5850-6.5.7, for detailed instructions on using this utility.</p>
<p><b>No</b></p>	<p>you see:</p>  <p>Click on <b>OK</b>.</p>

## Starting the Software

After you've rebooted your computer, follow these steps to start the software:

1. In the Allen-Bradley program group, select the **TemperatureControl** icon.

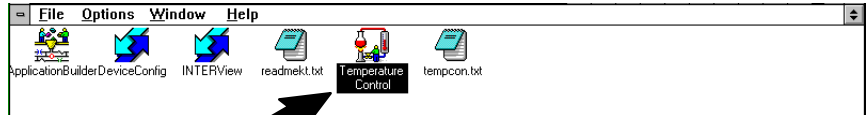

TemperatureControl icon

2. From the File pull-down menu, select Open.

As it loads the software, a welcome screen appears.

When the software is loaded, you see the Temperature Control Project screen:

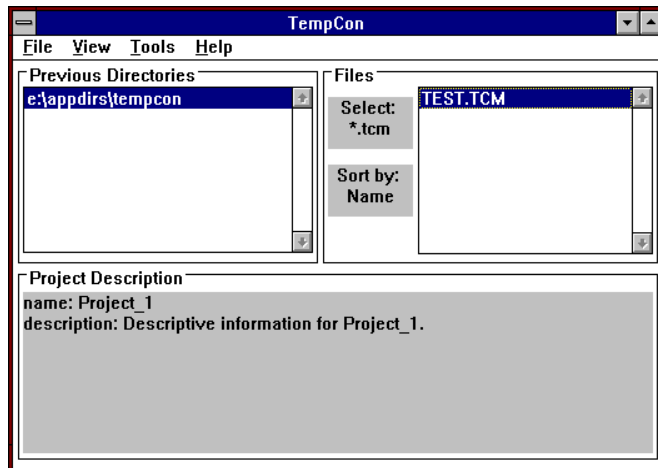

## Using Online Help

To access the TemperatureControl software online help, from the Help pull-down menu, you can select Contents:

You see the TemperatureControl online help Contents screen. Click on any of the underlined text to view the help on that topic.

You can also press F1 from any screen to view help for that screen.

To learn how to use the online help screens, from the Help pull-down menu, select **H**ow to Use Help. The How to Use Help screen appears.

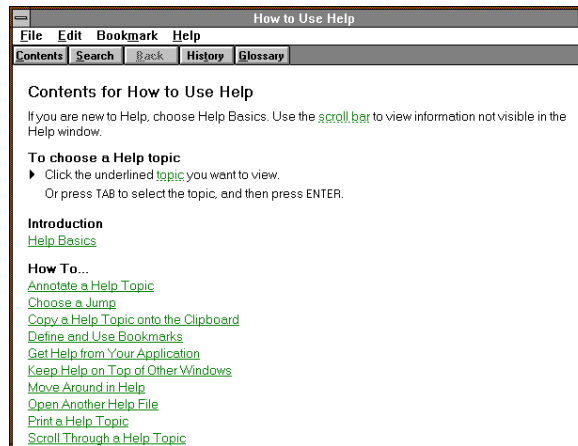

## What to do next

To learn how to organize the Temperature Control project file, read Chapter 3.

# AB Drives

## Organizing the Project File

This chapter shows you how to organize a temperature control project file. This includes:

- a definition of the temperature control project file
- creating a project file
- adding modules to the project file
- modifying an existing module

### The Temperature Control Project File

Before you can configure a temperature control module, you must create a project file that includes the module and its loops. Each project file can hold information for one or more temperature control modules. Use a single project file for all modules used on a common project controlled by a PLC processor or multiple PLC processors on the DH+ link. For example, if a molding machine uses 5 TCM modules, use a single project file for all 5 modules.

For each temperature control module you add to the project file, you must establish:

- a symbolic name for the module
- the address on the DH+ link of the PLC processor for the module
- the starting address of the contiguous data table area for interfacing with the module

See chapter 1 for details of how this interface area must be arranged.

- the module location address (rack/group/slot)

### Creating a Project File

To create a project file:

1. Start the software as described in chapter 2 to show the temperature control modules directories.

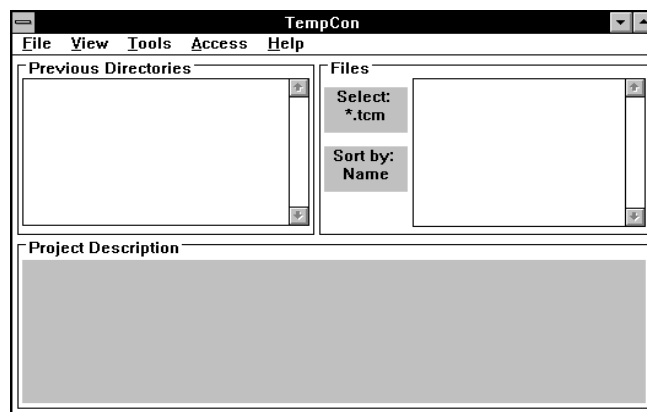



If you previously created and saved any project files, the directories where they were saved will be listed in the Previous Directories page. Click on a directory to display the project files in that directory. Click on a file to display its description, or double click on a file to open the Module Manager screen for that project.

2. From the File pull-down menu, select **New**.

The New-Project dialog box appears.

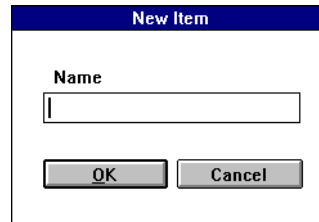

The dialog box titled "New Item" has a blue header bar. Below the header, there is a label "Name" followed by a text input field. At the bottom of the dialog, there are two buttons: "OK" and "Cancel".

3. Type the project/file name and then select **OK**. Use a short name that describes the project; for example, **Molding\_Machine\_1**. Spaces are not allowed. However, underscores are allowed.

The Module Manager screen for the project appears.

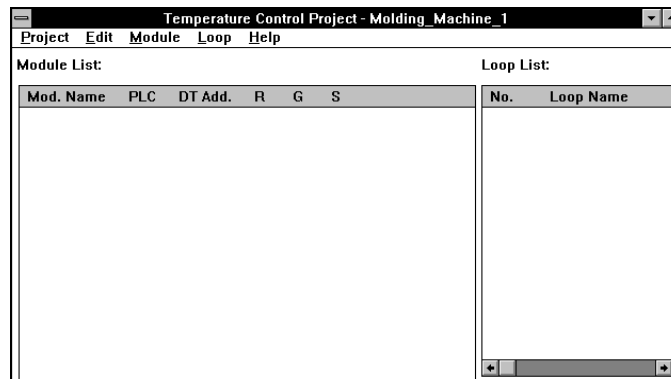

The Module Manager screen is titled "Temperature Control Project - Molding\_Machine\_1". It has a menu bar with "Project", "Edit", "Module", "Loop", and "Help". The screen is divided into two main sections: "Module List" and "Loop List".

Module List:						Loop List:	
Mod. Name	PLC	DT Add.	R	G	S	No.	Loop Name

At the bottom right of the Loop List section, there are scroll arrows.

# AB Drives

## Adding Modules to the Project File

To add a module to the project file:

1. From the Module pull-down menu, select New.

The New Module dialog box appears.

2. In this dialog box, enter the following for the module.

In this field:	Select on enter:
Name:	A short descriptive name to help you identify the module.
PLC Node:	The node number on the DH+ link of the PLC processor for the module. If you are using a DF1 link to the PLC processor, this value is ignored.
Port:	The INTERCHANGE port the software should use to communicate to the PLC processor. These ports are defined when you run the INTERCHANGE configuration utility. Most users configure only one port, and it will appear by default. If you have more than one port configured, click on the arrow to display the list.
DT Address:	The starting address of the contiguous data table area for interfacing with the module. (See chapter 1 on details of how this interface area must be arranged.)
Rack No.:	The I/O rack number for the module location address.
Group No.:	The I/O group number within the I/O rack for the module location address.
Slot No.:	0 — (The I/O module slot number within the I/O group.)

The rack, group, and slot numbers are for screen display reference only. It is up to your ladder logic to provide block-transfer to and from the correct location address for the module.

### 3. Select **OK**.

The module list for the project appears, with the module added. The new module will have 8 default loop names.

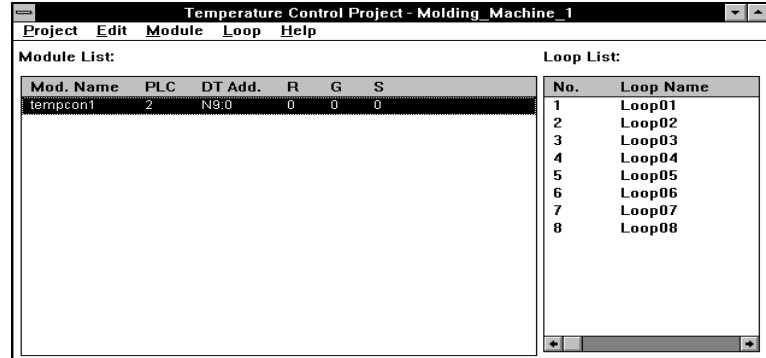

If you want to edit the project description that shows on the first screen, from the Project pull-down menu, you can select **Description**.

The project description is also printed when you print a project.

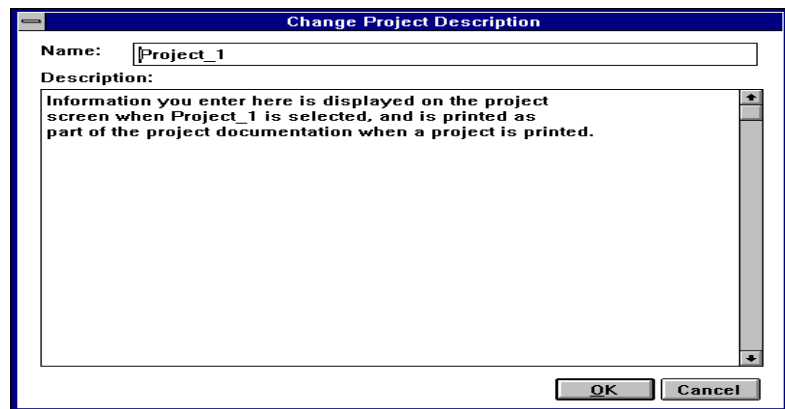

## Modifying an Existing Module

To change the Name, PLC Node, Port, Data Table Address, Rack, Group, or Slot of an existing module:

1. At the Module Manager screen, select the module you wish to modify.
2. From the Module menu, select **Modify**.

The Modify Module dialog box appears, with the current settings shown.

3. Make the desired changes and click on **OK**.

## What to do next

To learn how to configure the temperature control module, read chapter 4.

# AB Drives

## Configuring the Modules

This chapter shows you how to configure the 1771-TCM module. This includes:

- configuration selections
- uploading and downloading information
- accessing the Module Configuration screen
- downloading configuration values
- uploading configuration values
- module description
- copying configuration values from one module to another
- copying configuration values from one module into a new module
- moving a module from one project to another

### Configuration Selections

On the module configuration screen, you are given several configuration selections to establish. However, your selections do not control the PLC data table values in real time. These selections do not take effect until you download the selection to the PLC data table interface area.

### Uploading and Downloading Information

The configuration software can write (download) configuration information directly to the PLC data table in online mode, or it can write it to a disk file in off-line mode. Similarly, the configuration software can also read configuration information from the PLC processor or from a file.

In order to use online mode, you must have a DH+ or serial connection with the PLC processor, and INTERCHANGE must be properly configured and running. When you write configuration data to a file, it is stored as part of the project file. It is a good idea to always download to both the file and to the PLC processor. This way, the file retains a copy of all of the configuration data; you can then use this copy to restore the configuration data to the PLC processor if that information is ever lost or damaged.

Downloading to the file alone lets you perform configuration functions while you are disconnected from the PLC processor. Once you are attached to the PLC processor, you can transfer information from the file to the processor by first uploading from the file, and then downloading to the processor. When you are simply testing changes, you may want to download only to the PLC processor so that the file retains your un-altered settings. Once you are satisfied with those changes, you can download to the file to save them.

When you first open any of the configuration screens, the software attempts to perform an upload from the PLC processor so that the screen displays the current values the module is using. If the software cannot upload from the processor (e.g. if the connection to the processor has been broken), then the software performs an upload from the file. Now the data source (the PLC or file) is shown in the left-hand side of the status bar at the bottom of each configuration screen. The right-hand side of the status bar displays the destination when you perform a download.

While the software is uploading data from the PLC processor or file, it checks each value to make sure it is within the allowable range of values for the particular parameter. If the value is outside the allowable limits, it will be reset to a default value for that parameter. When this occurs, a warning message appears on the screen. Under normal conditions, this should not occur, but it may happen when you are uploading data from a module that has never been configured, since the data table will contain random data.

Normally, when you perform an upload or download, you are transferring information for a single loop only. Some screens allow you to upload or download information for all eight loops in a module at the same time. This is useful, for example, to download an entire module from the PLC processor and save it to a file without having to perform eight separate uploads and downloads. However, since the command can alter data you may not intend to alter, you are prompted for confirmation when you attempt to download an entire module at once.

Screens that are intended to monitor the module as it operates, such as the Loop Monitor screen or the Module Monitor screen, only display information from the PLC processor. If the connection to the processor is not available when you attempt to open a monitor screen, you will receive an error message and the screen will close.

## Accessing the Module Configuration Screen

To configure a module, access the module configuration screen:

1. At the Module Manager screen, select the module.
2. From the Module menu, select Configure.



### Accessing the Module menu

Clicking on the right mouse button while the pointer is over the module list on the Module Manager screen will display a popup version of the Module menu. (Clicking on the right mouse button brings up context-sensitive menus throughout the software.)

---

AB Drives

The Module Configuration screen for the module you selected appears.

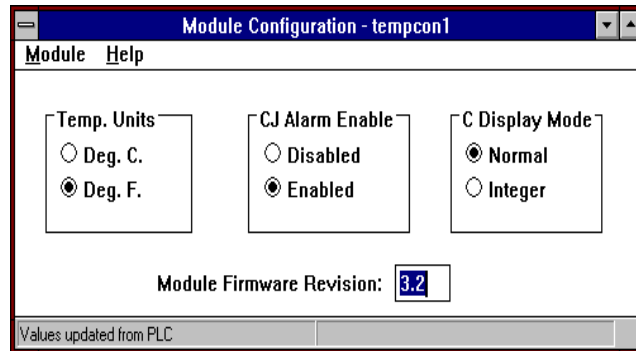

**3.** Select your desired temperature units (Celsius or Fahrenheit).

All temperature values will be displayed in the selected units, and you should enter all temperature values in these units.

**4.** Enable or disable the cold-junction alarms.

When cold-junction alarms are enabled, the cold-junction alarm bit in the data table will be set any time the cold-junction temperature exceeds seventy degrees Celsius, or falls below zero degrees Celsius.

**5.** Select the desired C Display Mode (Normal or Integer).

When you select Integer, the module will set the least significant digit (tenths of degrees) of the C Temperature output to 0. (You can view the temperature on the Loop Monitor and Module Monitor screens.)

For example:

If the Actual value is:	Then the Normal value is:	Or the Integer value is:
123.6	123.6	123.0
256.1	256.1	256.0
-127.3	-127.3	-127.0

This setting applies to all the loops in the module.

**Note:** This feature is only supported in Module Firmware Version 3.3. and later.

The Module Configuration screen displays the revision number of the module's firmware. This lets you determine the revision level of your module without removing the module from service.

**Note:** The module firmware revision will only be valid when data has been uploaded from the PLC processor.

## Downloading Configuration Values

Once you have made your desired selections on the Module Configuration screen, you must download these parameter values. To do so:

1. From the Module menu, select Download.



### Accessing the Download function

You may also access the Download function by pressing **CTRL + D**.

The Download dialog box appears.

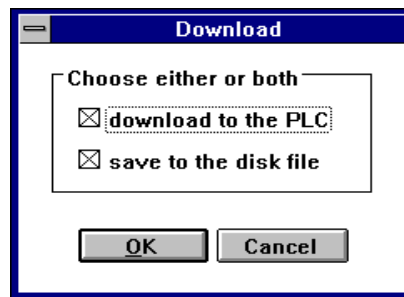

If you choose:	Then:
Download to PLC	the configuration values are downloaded to the PLC data table block. From there, the ladder logic block-transfers them to the TCM module.
Save to the disk file	the configuration values are downloaded to the disk file, from where they can be uploaded as needed.

2. Select either or both and click on **OK**.

The values are then downloaded, the dialog box closes, and the right-hand section of the status bar at the bottom of the window is updated to show the values were downloaded.

Some screens have both Loop and Module menus. On these screens, when you select upload or download from the Loop menu, the only data transferred is that for the loop on which the screen was opened. When you select upload or download from the Module menu, the data for all eight loops of the module are transferred. This is useful, for example, to upload an entire module from the PLC processor and then save it to the disk file, without having to go to eight separate screens and perform eight separate uploads and downloads. Because this command, if used improperly, can alter data you did not intend to alter, you are prompted for confirmation when you attempt to perform a module download.

# AB Drives

## Uploading Configuration Values

Although an automatic upload is performed when a screen first opens, you may also perform a manual upload at any time. This is useful, for example, when you want to transfer data stored in the disk file to the PLC processor by first uploading from the file and then downloading to the processor.

To upload configuration values:

1. From the Module menu, select Upload.



---

### Accessing the Upload function

You may also access the Upload function by pressing **CTRL + U**.

---

The Upload dialog box appears.

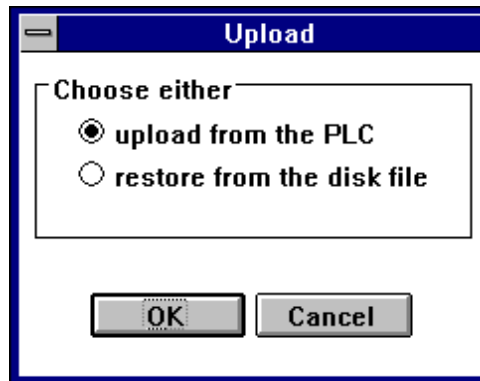

2. Select your desired upload source and click on **OK**.

The values are then uploaded, the dialog box closes, and the left-hand section of the status bar at the bottom of the window is updated to show the values were uploaded.

Some screens have both Loop and Module menus. On these screens, when you select upload or download from the Loop menu, the only data transferred is that for the loop on which the screen was opened. When you select upload or download from the Module menu, the data for all eight loops of the module are transferred. This is useful, for example, to upload an entire module from the PLC processor and then save it to the disk file, without having to go to eight separate screens and perform eight separate uploads and downloads. Because this command, if used improperly, can alter data you did not intend to alter, you are prompted for confirmation when you attempt to perform a module upload.



## Module Description

You can enter descriptive information for each module. This can be any information you wish to associate with the module, such as physical location, product being manufactured, etc. You can view this information at any time; it is included in printed reports, as well.

To enter or view the module description:

1. At the Module Manager screen, select a module.
2. From the Module menu, select Description...

The Module Description screen is displayed for the module you selected.

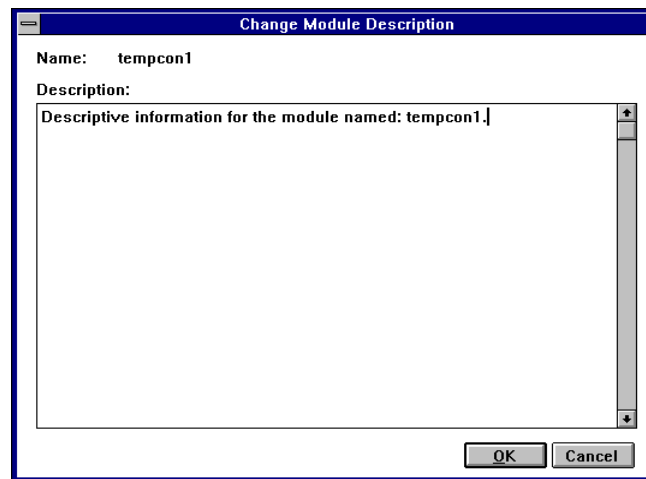

3. Enter or edit the description for the module and click on **OK**.

## Copying Configuration Values From One Module to Another

If you have several modules that are similar or identical, you can configure one module and then use that module to configure other similar modules.

**Note:** Before you do this, you may wish to perform the loop configuration described in Chapter 5 of this manual, and the tuning configuration described in Chapter 6. That way, those settings will be copied to the other modules as well.

To copy configuration data from one module to another:

1. At the Module Manager screen, select the first (source) module.
2. From the Edit menu, select Copy.
3. Select the second (destination) module.

The destination module can be in the same project or a different project.

AB Drives

4. From the Edit menu, select Paste into selection.
5. Go to each configuration screen for the destination module, view the pasted data, make any required changes, and then download to the PLC processor, to a file, or to both to save the pasted data.

To save all configuration parameters, you must do this from the Module Configuration, Loop Configuration, Tuning Configuration, and Tuning Results screens, since each of these screens downloads (or uploads) only the parameters shown on the particular screen.

From the Loop Configuration, Tuning Configuration, and Tuning Results screens, you can simultaneously download all eight loops at once by using the Module Download command.

### Copying Configuration Values From One Module Into a New Module

You can also use one module to configure another new module.

**Note:** Before you do this, you may wish to perform the loop configuration described in Chapter 5 of this manual, and the tuning configuration described in Chapter 6, so that those settings are copied to the new module as well.

1. At the Module Manager screen, select the first (source) module.
2. From the Edit menu, select Copy.
3. From the Edit menu, select Paste into new.

The New Module dialog box appears.

4. Fill in the information in the dialog box and click on **OK**.

The new module will be added to the module list.

5. Go to each configuration screen for the destination module, view the pasted data, make any required changes, and then download to the PLC processor, to a file, or to both to save the pasted data.

To save all configuration parameters, you must do this from the Module Configuration, Loop Configuration, Tuning Configuration, and Tuning Results screens, since each of these screens downloads (or uploads) only the parameters shown on the particular screen.

From the Loop Configuration, Tuning Configuration, and Tuning Results screens, you can simultaneously download all eight loops at once by using the Module Download command.

## Moving a Module From One Project to Another

To move a module from one project to another:

1. At the Module Manager screen, select the module you wish to move.
2. From the Edit menu, select Cut.
3. Close the Module Manager screen.
4. From the Project Manager screen, open the destination project (or create a new project).
5. From the Edit menu, select Paste into new.

The New Module dialog box appears.

6. Fill in the information in the dialog box and click on **OK**.

The new module will be added to the module list.

7. Go to each configuration screen for the destination module, view the pasted data, make any required changes, and then download to the PLC processor, to a file, or to both to save the pasted data.

To save all configuration parameters, you must do this from the Module Configuration, Loop Configuration, Tuning Configuration, and Tuning Results screens, since each of these screens downloads (or uploads) only the parameters shown on the particular screen.

From the Loop Configuration, Tuning Configuration, and Tuning Results screens, you can simultaneously download all eight loops at once by using the Module Download command.

## What to do next

To learn how to configure the loops of the temperature control module, read chapter 5.

# AB Drives

## Configuring the Loops

This chapter shows you how to configure the PID loops of the 1771-TCM module. This includes:

- changing default loop names
- configuration selections
- thermocouple break detection
- thermal integrity detection
- alarm dead band
- fine-tuning the loops
- bringing up the Loop Configuration screen
- entering configuration values
- downloading configuration values
- uploading configuration values
- using one loop to configure another

### Changing Default Loop Names

To change default loop names:

1. At the Module List screen, select the module for which you want to generate the loop list.

As you select a module on the Project screen, the loop list for that specific module is displayed.

2. Select a loop.
3. From the Loop pull-down menu, select Name.

The Loop-Name dialog box appears.

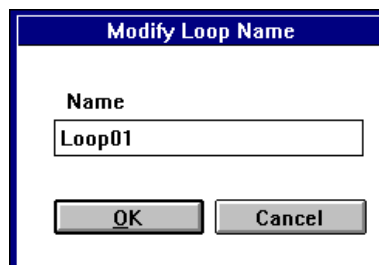

4. Enter a symbolic name for the loop.
5. Select **OK**.

You see the loop list for the module.

6. Repeat from step 2 until you have made all desired changes to the loop list.

Module List:						Loop List:	
Mod. Name	PLC	DT Add.	R	G	S	No.	Loop Name
tempcon1	2	N9.0	0	0	0	1	LoopZ1
						2	LoopZ2
						3	LoopZ3
						4	LoopN
						5	Loop05
						6	Loop06
						7	Loop07
						8	Loop08

## Configuration Selections

On the Configuration screen, you are given several configuration selections to establish. However, your selections do not control the PLC data table values in real time. These selections do not take effect until you download the selections to the PLC data-table interface area.

## Open-Circuit Detection

If a loop input circuit becomes open (a wire breaks or vibrates loose) the loop can not measure the temperature. In automatic mode, the lack of temperature feedback would make it impossible to control the temperature. To guard against such a lack of temperature control, the module provides open-circuit detection.

You select a mode to which the loop is to switch when an open input circuit is detected in automatic mode. The selections are:

- disable the PID loop by forcing the manipulated variable (M) value to zero
- set the output to the open-circuit forced M value
- set the loop to the manual mode (force M to manual output value)

# AB Drives

## Barrel/Non-Barrel Control

Under control type, you select between barrel and non-barrel control. Barrel control can be used for either heat-only or heat/cool applications. Non-barrel control can be used for either heat-only, cool-only, or heat/cool applications.

**Barrel control** is for multiple-zone applications in which there is thermal conduction between the zones. Injection molding and extruding are good examples of this because there are multiple heater bands (zones) mounted on one thermal conductor (the metal barrel). The barrel conducts heat between the different zones. If you select barrel control, you must also select between inner and outer zone. If you select barrel control, the non-barrel auto-tune disturbance size does not apply. A barrel loop is auto-tuned as the temperature rises from ambient to a fixed set point during startup.

**Non-barrel control** is for independent loops with no thermal conduction between the zones. If you select non-barrel control, the inner/outer zone selection does not apply. If you select non-barrel control, the loop is auto-tuned as it reacts to the set point disturbance you enter.

### Switch to Barrel Control?

For some applications, even though the loops are independent with no thermal conductivity between zones, barrel control may provide better performance than non-barrel control. If a loop has any of these characteristics, you may want to try switching it to barrel control.

- The time constant is greater than 100.0 seconds. (You can read the time constant for each loop in the auto-tune block.)
- The loop has a problem overshooting the set point.
- The loop output is saturating (the M at 100%) for a significant duration.

If you switch a loop to barrel control for one of these reasons, select it to be an outer zone.



**ATTENTION:** If you switch a loop between non-barrel control and barrel control, you must auto-tune the loop again before operating it. If you fail to auto-tune the loop after making such a switch, the auto-tuning values will be wrong for the application and the gains will be greatly distorted.

---

## Inner/Outer Zone

If you make the selection for barrel temperature control, you also have a selection for whether it is an inner zone or an outer zone. An outer zone is a zone at either end of the barrel. An inner zone is any zone other than at the very end of the barrel (between two other zones). The PID gain calculation algorithm for an inner zone is slightly different from that for an outer zone to account for an inner zone being more affected by adjacent zones. The inner zones are treated as more of an integrating process than are outer zones.

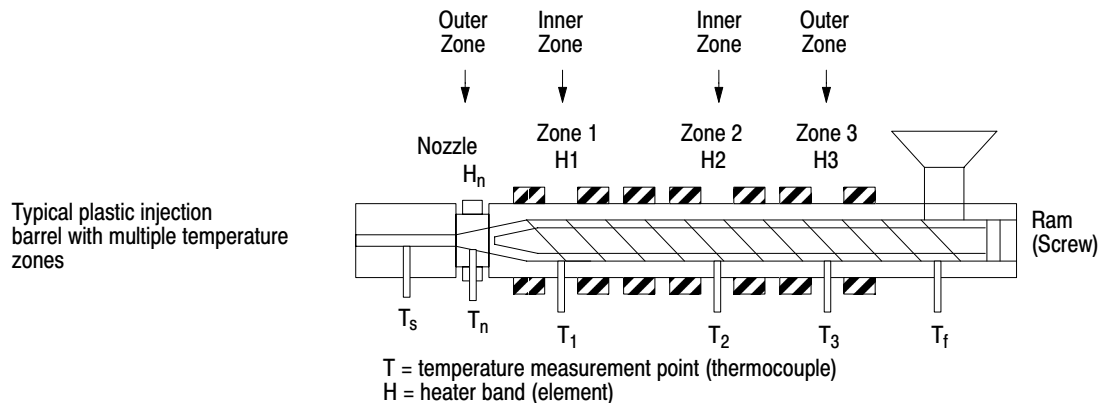

## Thermal Integrity Loss Detection

The loss of thermal integrity is detected when the loop M output is at 100% while the temperature rate of change measured by the module is below the minimum expected rate. Detecting the loss of thermal integrity requires an assumption of a minimum rate of change in the temperature input value (C) when the M output is at 100%. An example of a loss of thermal integrity could be because the contactor for a heating band fails open; or the sensor is not in proper position to measure the true temperature.

The values you enter for period and temperature change establish a minimum rate of change ( $^{\circ}/\text{min}$ ) in the temperature input value that you will allow when the M output is at 100%. The temperature change value you enter divided by the period value you enter is the thermal integrity rate. You select a mode for switching the M output to a forced value when the rate of change of the temperature does not reach the minimum for thermal integrity. The selections are:

- disable the PID loop by forcing the M value to zero
- set the output to the thermal runaway forced M value
- set the output to the manual-mode M value by setting the loop into manual mode

If a thermal integrity loss is detected, you must disable the affected loop and then re-enable it to clear the condition. You can do this from the Change Settings screen.

# AB Drives

## Alarms

In the Loop Configuration screen, you select values for the following temperature-level alarms:

- low temperature alarm
- high temperature alarm
- low deviation alarm (deviation from the set point)
- high deviation alarm (deviation from the set point)

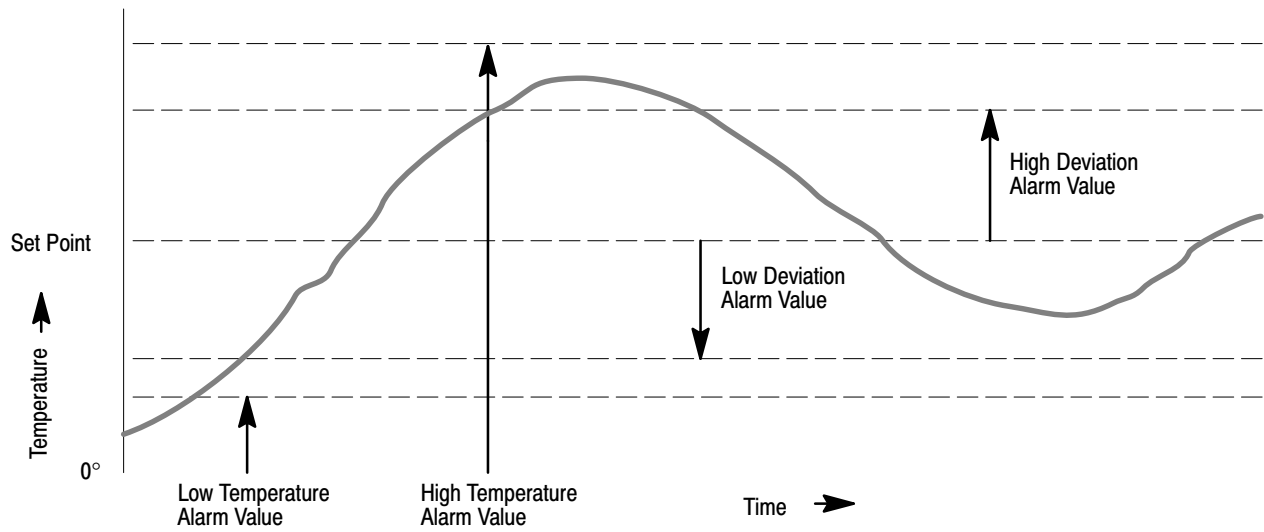



## Alarm Dead Band

Once the temperature alarm bits are on, they are kept on until the temperature drops below the high alarm by the alarm dead-band value or rise above the low alarm by this value. You specify the temperature alarm dead band. This dead band provides a hysteresis effect. The dead-band value applies to the high and low temperature and deviation alarm values.

- Low Alarm With Dead Band** — When the temperature falls below the user-defined low alarm value, the low alarm bit is turned on. When the temperature rises above the level of the low alarm value but still below the level of the dead-band value, the low alarm bit remains on. Only when the temperature rises above the dead-band level will the alarm bit be turned off.
- High Alarm With Dead Band** — When the temperature rises above the user-defined high alarm value, the high alarm bit is turned on. When the temperature falls below the level of the high alarm value but still above the level of the dead-band value, the high alarm bit remains on. Only when the temperature falls below the dead-band level will the alarm bit be turned off.

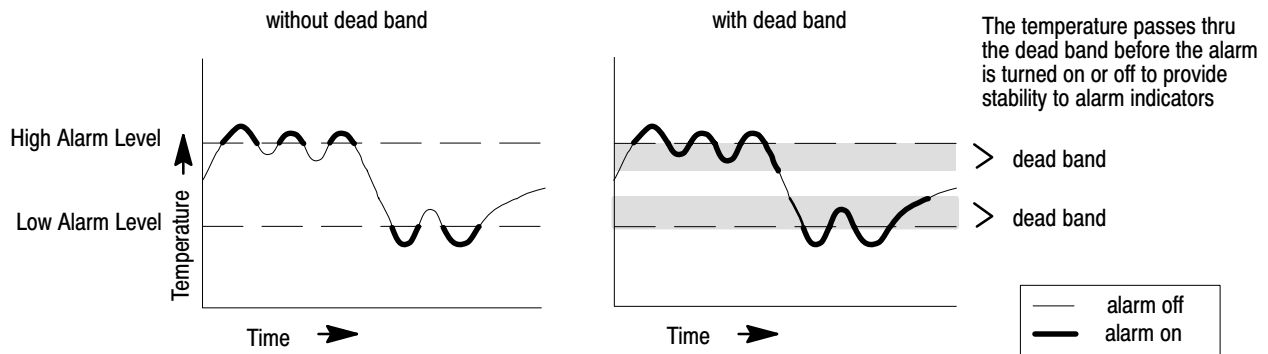

## TPO Bit

The ladder logic can send the TPO signal to a digital output module to generate the control variable output signal to a digital temperature control actuator.

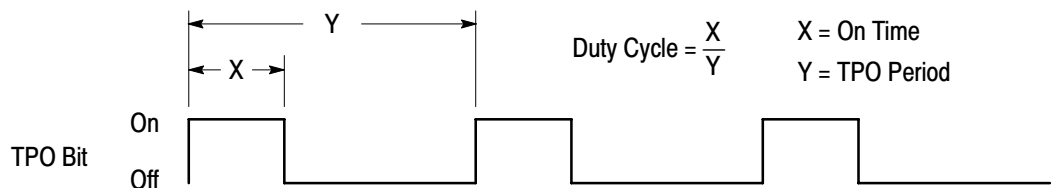

You set the period and minimum on time for each loop's heat and cool TPO bits. You must set the TPO period to be less than the system lag time (i.e. deadtime plus the time constant; this time is available from the autotune results). If the TPO period is greater than the lag time, the auto-tuning will calculate large gain values, which will probably cause the temperature to overshoot the set point.



In general, a smaller TPO period provides smoother control unless the minimum on time is greater than 10% of the TPO period. If the the minimum on time is greater than 10% of the TPO period, the TPO signal will not be able to provide any control of the temperature until the temperature has moved away from the set point far enough to require a 10% TPO signal.

A long minimum on time reduces wear on the heating or cooling contactors by reducing the cycling when the duty cycle is low. However, a short minimum on time provides smoother control, especially if the TPO period is short.

## Accessing the Loop Configuration Screen

To configure a loop, access the Loop Configuration screen as follows:

1. At the Module Manager screen, select the module.
2. Select the loop to configure.
3. From the **Loop** pull-down menu, select **Configure**.

### Displaying the popup Loop menu

To display a popup version of the Loop menu, click on the right mouse button while the cursor is over the loop list.

The Loop Configuration screen for the loop you selected appears.

The screenshot shows the 'Loop Configuration Screen - Project\_1.Loop001'. The interface includes the following sections:

- Setpoints:** Run Setpoint (150.0 Deg), Stdby Setpoint (0.0 Deg), Man. Out. Value (0.0 %), SP Ramp Rate (0.0 Deg/m), SP Ramp Enable (Disabled).
- Alarm Settings:** High Temp (0.0 Deg), High Dev. (0.0 Deg), Low Temp (0.0 Deg), Low Dev. (0.0 Deg), Deadband (0.0 Deg), C Rate (0.0 Deg/s).
- Temperature Sensor:** Type (mV), Filter (Enabled), TC (9.9), Open Circuit Action (Disable Loop (M=0)), Open Circuit M Value (0.0 %).
- Heat / Cool Settings:** Max. M (100.0 %), Min. M (-100.0 %), TPO Period (Heat: 5.0 Sec, Cool: 5.0 Sec), Min. On (Heat: 0.5 Sec, Cool: 0.1 Sec).
- Thermal Integrity Loss:** TIL Configuration (Disable Loop (M=0)), TIL Forced M Value (0.0 %), TIL Period (0.0 Minutes), TIL Temp. Change (0.0 Degrees).
- Auto / Man:** Manual (radio button), Auto (radio button, selected).
- System Response:** Slow (radio button), Med. (radio button), Fast (radio button, selected).
- Control Type:** Barrel (radio button, selected), Non-Barrel (radio button).
- Zone:** Inner (radio button, selected), Outer (radio button).
- Control Action:** E=SP-C (radio button, selected), E=C-SP (radio button).

Values updated from PLC



---

### Viewing configuration data

If you want to view the configuration data for a different loop, you can select **N**ext or **P**revious from the **L**oop menu to cycle through the loops. You can also press **CTRL + N** or **CTRL + P**.

---

## Entering Loop Configuration Values

Enter loop configuration values within the stated ranges. In each case where a decimal point is shown, if you want to enter a digit to the right of the decimal point, you must type in the decimal point; the decimal point is not inferred.

---



### Listing acceptable values

When you position the mouse pointer over a field that requires a numeric entry (e.g. Run Set point), there will be a brief delay, after which a small window appears that identifies the acceptable range of values for that parameter. You can find additional information in the online help.

---

The following table provides you with the appropriate values to enter for each field.

In this field:	Enter this value:
Run Setpoint	0.0 thru 3276.7°
Standby Setpoint	0.0 thru 3276.7°
Manual Output Value	-100.00 thru +100.00
SP Ramp Rate	0.00 thru 99.99°/min — If enabled, the rate at which the current set point is increased or decreased to reach the selected set point.
SP Ramp Enable	Toggles between enable and disable
Max. M Limit	-100.00 thru +100.00% — The maximum M percentage allowable.
Min. M Limit	-100.00 thru +100.00% — The minimum M percentage allowable.
Heat TPO Period	0 thru 100.00s — The period in seconds at which the heat bit is cycled and the M is updated.
Heat Min. On Time	0 thru 100.00s — The minimum time in seconds for which the heat bit is turned on during the TPO period. If the calculated time is less than this minimum, the heat bit will not be turned on. This on time must be less than the heat TPO period.
Cool TPO Period	0 thru 100.00s — The period in seconds at which the cool bit is cycled and the M is updated.
Cool Min. On Time	0 thru 100.00s — The minimum time in seconds for which the cool bit is turned on during the TPO period. If the calculated time is less than this minimum, the cool bit will not be turned on. This on time must be less than the cool TPO period.
High Temp Alarm	-3276.8 thru 3276.7° — A temperature value at the high end of the sensor limit, but still below the maximum temperature value.
Low Temp Alarm	-3276.8 thru 3276.7° — A temperature value at the low end of the sensor limit, but still above the minimum temperature value.
High Deviation Alarm	-3276.8 thru 3276.7° — A value that specifies the greatest deviation above the set point that the process can tolerate.
Low Deviation Alarm	-3276.8 thru 3276.7° — A value that specifies the greatest deviation below the set point that the process can tolerate.
Dead Band for Alarms	0.0 thru 10.0° — Once the temperature alarm bits are on, they are kept on until the temperature drops below the high alarm point by this value rises above the low alarm point by this value. The dead-band value applies to all alarms.
C Alarm Rate	-3276.8 thru 3276.7°/s — If the rate of temperature (C) increase is greater than this value, the C rate alarm is triggered. A value of 0.0 disables the C rate alarm.
Temperature Sensor Type	mV, B, E, J, K, R, S, T
Temperature Sensor Filter	When enabled, the C input is passed through a first order step equivalent lag filter. The filter's time constant is determined by the value entered in the TC field. Note: This feature is only supported in Module Firmware Version 3.3 and later.
Temperature Sensor TC	This is the filter time constant for the C input filter, and can range from 0.0 to 9.9 seconds. A setting of 0.0 effectively disables the filter. Note: This feature is only supported in Module Firmware Version 3.3 and later.
Open Circuit Action	<ul style="list-style-type: none"> <li>• Disable Loop (M=0)</li> <li>• M = On Break M value — The forced M value on TC break.</li> <li>• M = Manual Output value</li> </ul>
Open Circuit M Value	-100.00 thru +100.00 — The percentage value to force into the M output when a broken TC is detected.
TIL Configuration	<ul style="list-style-type: none"> <li>• Disable Loop (M=0)</li> <li>• M = On TIL M — The forced M value on thermal integrity loss.</li> <li>• M = Manual Output value</li> </ul>
TIL Forced M Value	-100.00 thru +100.00 — The percentage value to force into the M output when thermal integrity loss is detected.
TIL Period	0 thru 100 minutes
TIL Temp. Change	0 thru 100°
Auto / Manual	Auto or Manual
Desired System Response	Slow, Medium, Fast, or Very Fast — The system response desired as a result of auto-tuning. This selection will be used together with system parameter measured during auto-tuning to generate the auto-tuning gains.
Control Type	Barrel or Non-Barrel
Zone	Inner or Outer
Control Action	E = SP-C or E = C-SP

## Downloading Configuration Values

Once you have entered the appropriate values at the Configuration screen, you must download these parameter values. To do so:

1. From the Loop pull-down menu, select Download.



### Accessing the Download function

You may also access the Download function by pressing CTRL + D.

The Download dialog box appears.

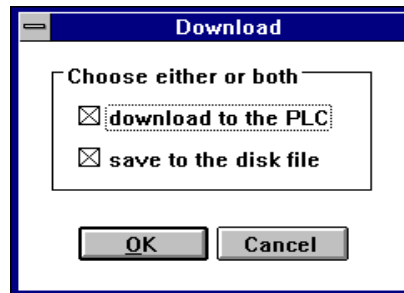

If you choose:	Then:
Download to PLC	the configuration values are downloaded to the PLC data table block. From there, the ladder logic block-transfers them to the TCM module.
Save to the disk file	the configuration values are downloaded to the disk file, from where they can be uploaded as needed.

2. Select either or both and click on **OK**.

To configure the loop, choose **download to the PLC**.

At this point the Download dialog box is removed from the Configuration screen, and the module configuration is complete.

# AB Drives

## Uploading Configuration Values

In the case that you are reconfiguring a loop or group of loops, you may find it useful to first upload the old configuration values for that module. Also, after downloading, you'll want to verify that the PLC processor received the correct information. To do so, at the **Loop** pull-down menu, select **Upload**.

1. From the **Loop** pull-down menu, select **Upload**.



### Accessing the Upload function

You may also access the Upload function by pressing **CTRL + U**.

The Upload dialog box appears.

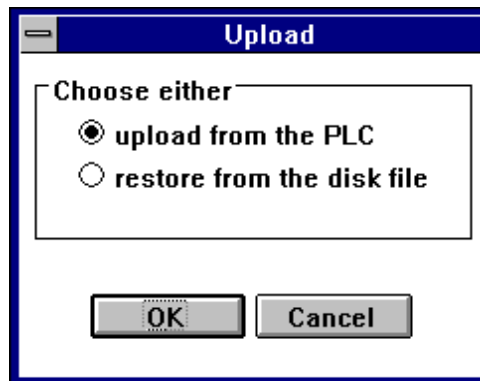

2. Select your desired upload source and click on **OK**.

## Using One Loop to Configure Another

If you have several loops that are similar or identical, you can configure one loop and then use that loop to configure the other similar loops.

To copy configuration data from one loop to another:

1. At the Module Manager screen, select the loop that has the desired configuration (i.e. the source loop).

2. From the Edit menu, select Copy.

The values from the source loop will be placed on the Windows clipboard.

3. Select the second (i.e. destination) loop

The destination loop can be in the same module, a different module, or a different project.

4. From the Edit menu, select Paste into selection.

5. Go to each configuration screen for the destination loop, view the pasted data, make any required changes, and then download to a file, to the PLC processor, or both to save the pasted data.

To save all configuration parameters, you must do this from the Loop Configuration screen, Tuning Configuration screen, and the Tuning Results screen, since each of these screens downloads (or uploads) only those parameters shown on the screen.

Note: When you open a screen that has pasted data, the automatic upload from the PLC processor or the file is inhibited to prevent overwriting the pasted data, and the status pane displays the message “Values pasted from clipboard.”

When you paste into a loop, the name of the destination loop remains the same, but all the configuration values are replaced with those from the source loop. The values used from the source loop are those that were last displayed on the configuration screens for that loop. In other words, if you perform an upload from a file for the source loop and then perform a copy command, the values that are placed on the clipboard are those from the file, whereas if you perform an upload from the PLC processor prior to performing the copy, the PLC values are placed on the clipboard.

# AB Drives

## Loop Description

You can enter descriptive information for each loop. This can include any information you wish to associate with the loop, such as physical location, product being manufactured, etc. You can view this information at any time; it is also included in the printed reports.

To enter or view the loop description:

1. At the Module Manager screen, select a loop.
2. From the Loop menu, select Description...

The Loop Description screen appears for the loop you selected.

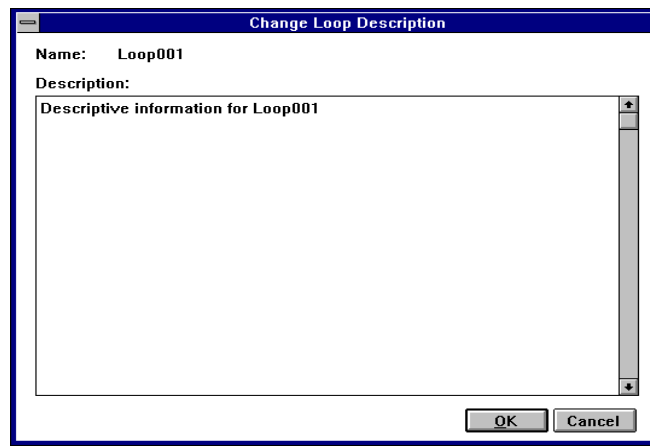

3. Enter or edit the description for the loop and click on **OK**.

## What to do next

To learn how to tune the loops, read chapter 6.



**Notes:**

AB Drives

## Tuning the Loops

This chapter shows you how to tune a loop. This includes:

- configuring tuning
- auto-tuning the loops
- viewing auto-tuning results
- changing system response
- fine-tuning the loops

### Introduction to Loop Tuning

Before a PID loop can be run in automatic control mode, the proportional, integral, and derivative gains must be set. Traditionally, these gains have been set manually using a trial and error process. This manual process can be very time-consuming, and often results in less than optimal performance.

Although you can use the manual process to set the gains, the TCM module includes an advanced auto-tuning algorithm that is capable of automatically determining near optimum gain values. We recommend that you use the auto-tuning process to determine initial gain values, which can then be adjusted manually, if necessary, to correct any slight remaining performance problems.

### The Auto-Tuning-Process

During auto-tuning, the TCM module controls the loop output and monitors the change in the measured variable in order to measure several parameters that are characteristic of your process. Using these parameters, the TCM module then calculates proportional, integral, and derivative gains that will provide good automatic control. This process can take from a few minutes to several hours, depending on the response time of your process.

### Preparing to Auto-Tune Loops

Before you begin the auto-tuning process, we recommend that you perform several preparatory steps:

1. After configuring your module and loops, as described in Chapters 4 and 5, operate your loops in Manual mode.

By operating the loop in Manual mode, you can verify that the inputs and outputs are connected properly, the temperature sensors are correctly measuring your process temperature, and the loop output properly controls heating and/or cooling.

2. Once you are satisfied that your loop is operating properly in Manual mode, use the Manual Tuning screen to set the proportional gain to 1, leaving the integral and derivative gains at 0.

This configures the loop for straight proportional control.

3. Place the loop in Automatic mode.

With a proportional gain of 1, the loop output should be directly proportional to the deviation between the measured variable and the setpoint.

4. When you are satisfied the loop is operating properly in this mode, you can proceed with the auto-tuning process described in the following sections.

**Important:** You must allow the equipment to cool down before you begin the autotune process or your results will be invalid.

## Tuning Parameters

There are several tuning parameters that you can configure to tailor the auto-tuning process to suit particular applications: aggressiveness, disturbance size, and system response.

- Aggressiveness

The aggressiveness setting affects how the module controls the loop during start-up in barrel control mode. Start-up is the period between the time the loop is placed in Automatic control at a low initial temperature, and the time it first nears the setpoint.

This setting can range from 0 to 100. A setting of 0 minimizes the chance of overshoot during start-up, but increases the time needed to reach the setpoint. A setting of 100 minimizes start-up time, but will result in the temperature overshooting the setpoint during start-up.

This setting does not affect the quality of the control once the start-up period has passed. During an ideal start-up, the temperature should rise steeply toward the setpoint. As the temperature nears the setpoint, the rate of climb should gradually level off until the temperature reaches the setpoint. If the temperature drops for a while after the initial climb before slowly climbing toward the setpoint, you should increase the aggressiveness.

- Disturbance Size (non-barrel loops only)

Disturbance size is the percentage of the step change made in the output during auto-tuning of non-barrel loops. The disturbance size setting can range from 0.00 to 100.00. (**Note:** A setting of 0.00 is equivalent to a setting of 100.00.)

AB Drives

Since non-barrel loops are tuned starting from the setpoint, instead of from a low temperature, the step size should be chosen to keep the temperature within the operating range.

For example, assume your loop is at the setpoint of 100 degrees, and the loop output is at 20 percent, when auto-tuning is started. If the disturbance size is set to 10 percent, the output will be changed to 30 percent when tuning starts, which will, in turn, cause the temperature to rise to some value above the setpoint. You should make the disturbance size as large as possible, while still insuring that the temperature will not rise out of your process's operating range.

- System Response

The system response setting is used in conjunction with the system parameters measured during auto-tuning to determine the proportional, integral, and derivative gains. When you select slow, the system will react more mildly to changes in setpoint or temperature, but will not overshoot the setpoint. When you select fast, the system will react more strongly to changes in setpoint or temperature, but will likely overshoot the setpoint. This setting can be changed after a loop is tuned to make small adjustments in the performance of the loop.

## Configuring Tuning Parameters

Before you can auto-tune a loop, you must configure the tuning parameters. To do so:

1. At the Module Manager screen, select a loop.
2. From the Loop menu, select **C**onfigure tuning.

The Tuning Configuration screen is opened on the selected loop.

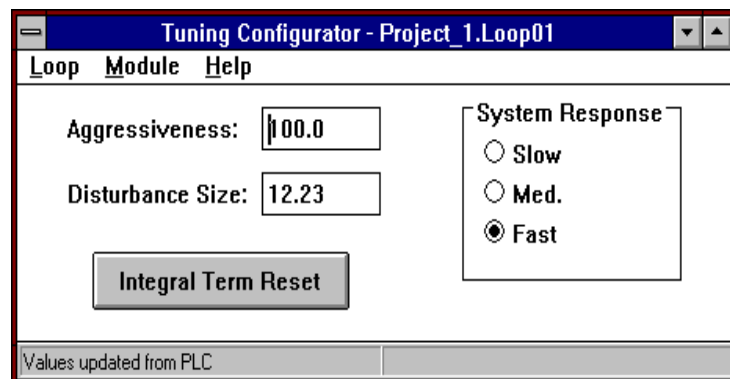

3. Enter your desired settings for aggressiveness and disturbance size, and select the desired system response.

**Note:** The Integral Term Reset button is not used during tuning configuration. Refer to Chapter 7 for information on using the Integral Term Reset button.

4. Download the tuning parameters.

## Auto-Tuning the Loops

Before you can auto-tune a loop, you must satisfy these prerequisites:

- Barrel loops must be at least 50 degrees F below the run setpoint before tuning is started; we recommend that you make the difference 100 or 150 degrees.
- The TPO period you configured for the loop should be less than the system lag time.

Lag time is the delay that occurs between a change in loop output and the start of the resulting temperature change. If the TPO period is longer than the lag time, the calculated gain values will not provide good control.

### Auto-Tuning Procedure

To start up and auto-tune loops, follow this procedure:

1. At the Module Manager screen, select the module for which you want to tune a loop or group of loops.
2. From the Module pull-down menu, select Tuning Assistant.

The Tuning-Assistant screen appears, showing all 8 loops of the module.

#	Name	Temp.(C)	SP.	Output(M)	Barrel/Non	Tun. Status
1	Loop001	282.3	290.0	11.52	Barrel	Successful
2	Loop002	289.9	290.0	0.0	Barrel	Successful
3	Loop003	291.0	290.0	0.0	Barrel	Successful
4	Loop004	280.9	290.0	11.54	Barrel	Successful
5	Loop005	2192.0	0.0	0.0	Barrel	Not Successful
6	Loop006	2192.0	0.0	0.0	Barrel	Not Successful
7	Loop007	2192.0	0.0	0.0	Barrel	Not Successful
8	Loop008	2192.0	0.0	0.0	Barrel	Not Successful

Module Status:

tempcon1: Cold-junction alarms are suppressed.  
 Loop001: All alarms are suppressed.  
 Loop001: Parameter value error.  
 Loop001: Heat auto-tuning is inhibited because of the starting conditions.  
 Loop002: All alarms are suppressed.  
 Loop002: Parameter value error.  
 Loop002: Heat auto-tuning is inhibited because of the starting conditions.  
 Loop003: All alarms are suppressed.

Buttons: All, None, Barrel, Start Tuning

3. Select the loops you want to tune. For barrel zones on the same barrel, select either all heat-only loops or all heat/cool loops. Auto-tuning heat-only loops at the same time with heat/cool loops may generate inappropriate gains.
  - Clicking on a loop will toggle between selecting and deselecting the loop.
  - Selecting **All** selects all loops. Selecting **None** deselects all loops.
  - Selecting **Barrel** selects all loops designated as barrel loops.

#### 4. Select **Start Tuning**.

Once the tuning process starts, the **Start Tuning** selection becomes **Stop Tuning**.

#### 5. If at any time during the process you want to stop the auto-tuning, select **Stop Tuning**.

During auto-tuning, do not close the Tuning Assistant screen, as this will prevent proper completion of tuning. You may minimize the window if desired.

As the tuning process progresses, the tuning status for each loop is reported as one of the following:

- Unknown
- In Process
- Successful
- Not Successful

When none of the loops are any longer reported as **In Process**, the auto-tuning is complete.

## Monitoring Auto-Tuning Results

After auto-tuning is complete, you can monitor the the auto-tuning results passed between the the TCM module and the PLC data table. To monitor the auto-tuning results, from the **Module** menu, select **Tuning Results**.

The Auto-Tuning Result screen appears.

Tuning Results - tempcon1									
Module	Loop	Help							
No.	Name	Heat P.G.	Heat I.G.	Heat D.G.	Cool P.G.	Cool I.G.	Cool D.G.	Heat Gain	Heat T.C.
1	LoopZ1	0.0	0.0	0.0	0.0	0.0	0.0	0.0	0.0
2	LoopZ2	0.0	0.0	0.0	0.0	0.0	0.0	0.0	0.0
3	LoopZ3	0.0	0.0	0.0	0.0	0.0	0.0	0.0	0.0
4	LoopN	0.0	0.0	0.0	0.0	0.0	0.0	0.0	0.0
5	Loop05	0.0	0.0	0.0	0.0	0.0	0.0	0.0	0.0
6	Loop06	0.0	0.0	0.0	0.0	0.0	0.0	0.0	0.0
7	Loop07	0.0	0.0	0.0	0.0	0.0	0.0	0.0	0.0
8	Loop08	0.0	0.0	0.0	0.0	0.0	0.0	0.0	0.0

Values updated from disk file

On this screen, for both heat and cool for each loop, the following values are displayed:

- controller gain
- integral gain
- derivative gain
- slope (process gain for non-barrel loops)
- time constant
- dead time

You must scroll horizontally to view all columns. The slope, time-constant, and dead-time values are the measured process dynamics that the module uses together with the system response (slow, medium, or fast) you enter at the Loop Configuration screen to calculate the PID gains (controller gain, integral gain, and derivative gain).

## Downloading Tuning Results

When you select **Download** from the **Loop** or **Module** menu on the Tuning Results screen, you are prompted to select either PID values or system dynamics values.

If you select:	Then:
PID values	the proportional, integral, and derivative gains for heating and cooling are downloaded.
System Dynamics values	the gain, deadtime, and time constant values for heating and cooling are downloaded.

The parameters on this screen are divided into two groups because downloading the System Dynamics values automatically causes the module to recalculate the PID values.

## Fine-Tuning the Loops

After auto-tuning, you may want to fine-tune the loops. As you fine-tune a loop, first try adjusting the controller gain; this will have the greatest impact. Your second choice for adjustment should be the integral gain. The derivative gain should be the last choice for fine-tuning a loop.

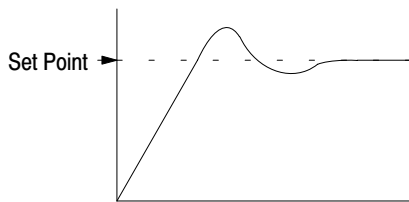

If the loop has a problem **overshooting** the set point, you may be able to improve the loop response by doing one or more of the following (in order of effectiveness):

1. decrease the controller gain
2. decrease the integral gain
3. increase the derivative gain

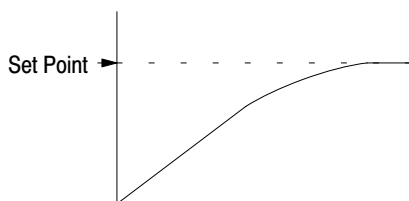

If the loop is **slow** in reaching the set point, you may be able to improve the loop response by doing one or more of the following (in order of effectiveness):

1. increase the controller gain
2. increase the integral gain
3. decrease the derivative gain

# AB Drives

## Fine-Tuning Procedure

To fine-tune a loop:

1. At the Module Manager screen, select the module and loop you want to fine-tune.
2. At the Loop menu, select **Manual Tune**.

The Manual-Tuning screen appears.

	Current	New
Heating Proportional Gain:	4.7	4.7
Heating Integral Gain:	0.11	0.11
Heating Derivative Gain:	2.0	2.0
Cooling Proportional Gain:	3.6	3.6
Cooling Integral Gain:	0.07	0.07
Cooling Derivative Gain:	3.0	3.0

Download Close

In this field:	Enter this value:
Heat Controller Gain	0 thru 32.767
Heat Integral Gain	0 thru 3.2767 repeats/s
Heat Derivative Gain	0 thru 3276.7s
Cool Controller Gain	0 thru 32.767
Cool Integral Gain	0 thru 3.2767 repeats/s
Cool Derivative Gain	0 thru 3276.7s

3. Fine-tune each gain as necessary.
4. Select **Download**.



## Changing the System Response Setting After Tuning is Complete

You can change the system response setting after auto-tuning is complete, provided you follow these steps:

1. At the Tuning Results screen, select the loop you wish to alter.
2. From the Loop menu, select **Configure tuning**.



### Accessing the tuning configuration values

To access the configuration values for this loop, you can also double click on the loop.

The Tuning Configuration screen appears.

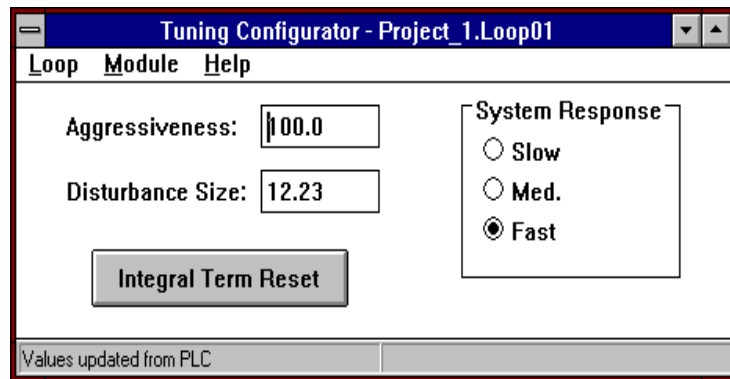

3. Change the system response setting.
4. Download to the PLC processor.
5. At the Tuning Results screen, download the system dynamics values for the loop.

This triggers the module to recalculate new proportional, integral, and derivative gains based on the system dynamics and the new system response setting.

## What to do next

To learn how to monitor and control the loops, read chapter 7.

# AB Drives

## Monitoring and Controlling the Loops

This chapter shows you how to monitor and control the PID loops. This includes:

- Loop Monitor screen
- changing loop settings
- Module Monitor screen

### Loop Monitor Screen

To monitor a loop of a particular module, at the Project screen, select the module and loop; from the Loop menu, select Monitor.

The Loop Monitor screen for the current loop appears.

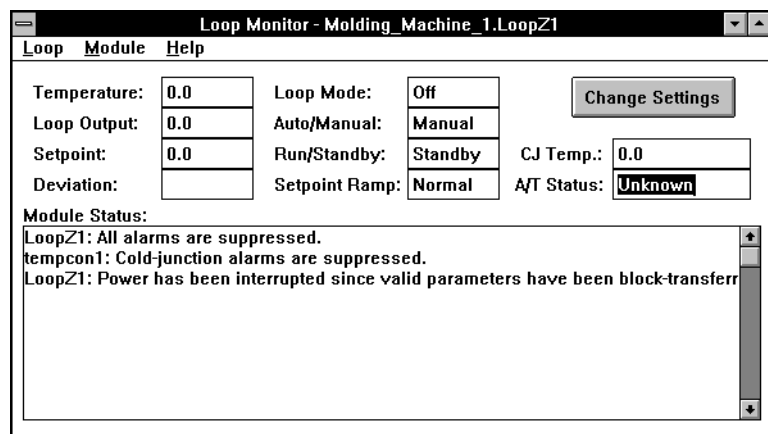

The values on this screen are refreshed about once per second.

If the set-point ramp field:

Indicates:	Then:
No Ramp	set-point ramping is disabled OR set point ramping is enabled, but the set point is currently not ramping
Up	set-point is increasing due to set point ramping
Down	set point is decreasing due to set point ramping
Holding	set point would be ramping, but the Ramp Hold bit is set

**Note:** With Module Firmware versions prior to 3.3, this field will display “No Ramp” when the set point is not ramping, and “Down” when the set point is ramping, regardless of whether it is ramping up or down.

The module status pane is used to display error messages. If the number of current error messages exceeds the number of lines that can be displayed, you can scroll thru the messages. The possible error messages include the following:

- high temperature alarm
- low temperature alarm
- high deviation alarm
- low deviation alarm
- high manipulated variable (M) alarm
- low (M) alarm
- input over range
- input under range
- TC break alarm
- loss of thermal integrity
- calibration fault
- CJ under range
- CJ over range
- Auto-tuning terminated because of thermal integrity loss.
- Auto-tuning terminated because of thermocouple break.
- Heat auto-tuning inhibited because of starting conditions.
- Cool auto-tuning inhibited because of starting conditions.
- Set point will be reached before auto-tuning is complete.
- Too much noise causing time constant to be 0.
- Very small gain.
- Set point exceeded before auto-tuning completed.

You may also see a message that says there is an error in a specific word of the configuration block, the gains block, or the dynamic block. In that case, refer to the user manual (publication 1771-6.5.120) to resolve the problem. This kind of problem would most likely be a result of ladder logic errors such as writing over the data-table interface area.

# AB Drives

## Changing Loop Settings

To change loop settings, at the Loop Monitor screen, click on **Change Settings**.

The Change-Settings dialog box appears.

## Entering Loop Settings

Enter loop settings values within the stated ranges. In each case where a decimal point is shown, if you want to enter a digit to the right of the decimal point, you must type in the decimal point. The decimal point is not inferred.

In this field:	Enter this value:
Loop Mode	Control, Monitor, or Off
Alarm Enable	Enable or Disable
Run/Standby	Run or Standby
Auto / Manual	Auto or Manual
SP Ramp Enable	enable or disable
SP Ramp Hold	Ramp or Hold When Hold is selected during set point ramping, the ramp will be stopped and the set point will hold at its current value. When Ramp is selected, the ramp will continue normally. After changing the selection, you must perform a download for your change to take effect. If Setpoint Ramping is disabled, this setting has no effect. Note: This feature is only supported in Module Firmware Version 3.3. and later.
Run Setpoint	0.0 thru 3276.7°
Standby Setpoint	0.0 thru 3276.7°
Manual Output Value	-100.00 thru +100.00

## To Cancel

At any time at the change-settings dialog box, you can select **Cancel**. This will cancel all of your selections at this dialog box and return you to the Loop Monitor screen.

## To Download

Once you have entered the appropriate values at the change-settings dialog box, you can download them to the PLC data-table interface area by selecting **Download**.

From this dialog box, you can not download to the disk file.

## Module Monitor Screen

To monitor the common functions of a particular module, at the Module Manager screen, select the module; from the Module menu, select **Monitor**.

The Module Monitor screen appears.

Temperature Control Module Monitor - testmod									
#	Name	Temp.(C)	SP.	Output(M)	Dev.	Mode	Auto/Man.	Run/Shy.	SP Ramp
1	Loop01	2192.0	0.0	0.0	0.0	Control	Auto	Run	Normal
2	Loop02	2192.0	150.0	12.0	2042.0	Control	Auto	Run	Normal
3	Loop03	2192.0	150.0	13.0	2042.0	Control	Auto	Run	Normal
4	Loop04	2192.0	150.0	14.0	2042.0	Control	Auto	Run	Normal
5	Loop05	2192.0	0.0	0.0	0.0	Off	Manual	Standby	Normal
6	Loop06	2192.0	0.0	0.0	0.0	Off	Manual	Standby	Normal
7	Loop07	0.0	0.0	0.0	0.0	Off	Manual	Standby	Normal
8	Loop08	0.0	0.0	0.0	0.0	Off	Manual	Standby	Normal

Module Status: Cold Junction Temperature:

testmod: Cold-junction temperature is below 0 degrees C.  
 Loop01: All alarms are suppressed.  
 Loop01: Power has been interrupted since valid parameters have been block-transferred.  
 Loop01: Parameter value error.  
 Loop01: Error in configuration block parameter at word: 3  
 Loop02: All alarms are suppressed.  
 Loop02: Temperature sensor circuit is open.  
 Loop02: Parameter value error.

## ▶ Changing loop settings

Double-clicking on a loop opens the Change Settings screen for that loop.

# AB Drives

## Documenting Projects, Modules, and Loops

This chapter shows you how to use the Temperature Control Module Configuration software to produce a printed record of your system, including descriptive information for each project, module, and loop, as well as the values of all configuration parameters. This includes:

- reports
- printing or viewing an entire project
- printing a single module or loop

### Reports

You can generate reports for an entire project, an individual module (including its loops), or an individual loop. Each section of the report includes a header showing the name of the item and its descriptive information, and a list of all the parameters that are part of the item, with the current value of each parameter also listed.

You can print reports on a printer attached to your computer, using the Print option, or you can view them on the screen, using the Print Preview option. These reports can display either the online (i.e. PLC processor) data values, or the offline (i.e. File) data values.

### Printing or Viewing an Entire Project

To print or view an entire project:

1. Open the Module Manager screen on the desired project.
2. From the **P**roject menu, select **P**rint to produce a printed report, or Print Preview to view the report on the screen.

A dialog box appears, prompting you to select File or PLC.

3. Select the set of values you wish to document.

The Print dialog box appears.

4. Make sure the **All** box is checked; if you are printing to a printer, be sure the printer information is correct and click on **OK**.

The report is printed or displayed on the screen.

## Printing a Single Module or Loop

To print a single module or loop:

1. Open the Module Manager screen on the project containing the module or loop you wish to document.
2. Select the module or loop you wish to document.
3. From the **P**roject menu, select **P**rint to produce a printed report, or **P**rint **P**review to view the report on the screen.

A dialog box appears, prompting you to select File or PLC.

4. Select the set of values you wish to document.

The Print dialog box appears.

5. Make sure the **S**election box is checked; if you are printing to a printer, be sure the printer information is correct and click on **OK**.

The report is printed or displayed on the screen.

# AB Drives

## A

alarm  
  dead band, [5-6](#)  
  hysteresis, [5-6](#)  
audience, [P-1](#)  
auto-tuning, [6-4](#)

## B

barrel/non-barrel, [5-3](#)  
block-transfer, [1-2](#)

## C

changing loop settings, [7-3](#)  
communication, how data is transferred,  
  [1-2](#)  
computer requirements, [2-1](#)  
configuration selections, [5-2](#)  
configuring the loops, [5-1](#)  
configuring the module, [5-1](#)  
organizing the project file, [3-1](#)  
Alarms, [5-5](#)  
controlling and monitoring loops, [7-1](#)

## D

dead band, [5-6](#)  
definitions, [P-2](#)  
disks, [2-2](#)  
drive convention, [2-2](#)

## E

error messages, [7-2](#)

## F

fine-tuning, [6-6](#)

## H

help, [2-2](#), [2-10](#)  
hysteresis, [5-6](#)

## I

inner/outer zone, [5-4](#)  
installation, software, [2-1](#)  
installation procedure, software, [2-2](#)  
installing the utility software, [2-1](#)  
installing Win32s files, [2-3](#)

## L

loop configuration, [5-1](#)  
loop list generation procedure, [5-1](#)  
loop monitor screen, [7-1](#)  
module monitor screen, [7-4](#)

## M

module configuration, [5-1](#)  
project list organization, [3-1](#)  
module list generation procedure, [3-1](#)  
module status, [7-2](#)  
monitoring and controlling loops, [7-1](#)  
monitoring auto-tuning results, [6-5](#)

## O

online help, [2-2](#), [2-10](#)  
open-circuit detection, [5-2](#)  
outer/inner zone, [5-4](#)

## P

PID loops, [1-2](#)  
procedure, loop list generation, [5-1](#)  
procedure, module list generation, [3-1](#)

## R

related publications, [P-2](#)  
requirements for your computer, [2-1](#)

## S

selections, configuration, [5-2](#)



set-point ramping, [7-1](#)  
single-transfer, [1-2](#)  
software disks, [2-2](#)  
software installation procedure, [2-2](#)  
software interface with PLC processors,  
[1-3](#)  
software, starting, [2-9](#)  
starting the software, [2-9](#)

## T

TC break detection, [5-2](#)  
terms, [P-2](#)  
thermal integrity loss detection, [5-4](#)

thermal runaway, [5-4](#)  
TPO, [P-2](#), [5-6](#)  
tuning, [6-1](#)  
    auto-, [6-4](#)  
    fine-, [6-6](#)  
tuning assistant, [6-4](#)

## V

vocabulary, [P-2](#)

## W

project file, [3-1](#)  
temperature control project file, [3-1](#)

## Customer Support

If you need additional assistance on using your software, Allen-Bradley offers telephone and on-site product support at Customer Support Centers worldwide

For technical assistance on the telephone, first contact your local sales office, distributor, or system integrator. If additional assistance is needed, then contact your local Customer Support Center or contact System Support Services.

For assistance that requires on-site support, contact your local sales office, distributor, or system integrator. During non-office hours, contact the Allen-Bradley 24-hour Hot Line at: 1-800-422-4913 in the United States or contact your local Customer Support Center outside the United States.

Customer Support Center phone numbers:

<b>Region or Area</b>	<b>Customer Support Center Telephone Number</b>
United States (Cleveland)	216-646-6800
Canada (Cambridge, Ontario)	519-623-1810
Latin America (Milwaukee)	414-382-2000
United Kingdom (Milton Keynes)	44-908-838800
Europe (Amsterdam)	31-2975-43500
France (Paris)	(33-1) 4778-1402
Germany (Gruiten)	(49) 2104-6900
Italy (Milan)	(39-2) 4830-0381
Asia Pacific (Hong Kong)	(852) 873-1342



Allen-Bradley, a Rockwell Automation Business, has been helping its customers improve productivity and quality for more than 90 years. We design, manufacture and support a broad range of automation products worldwide. They include logic processors, power and motion control devices, operator interfaces, sensors and a variety of software. Rockwell is one of the world's leading technology companies.



## Worldwide representation.

Argentina • Australia • Austria • Bahrain • Belgium • Brazil • Bulgaria • Canada • Chile • China, PRC • Colombia • Costa Rica • Croatia • Cyprus • Czech Republic • Denmark • Ecuador • Egypt • El Salvador • Finland • France • Germany • Greece • Guatemala • Honduras • Hong Kong • Hungary • Iceland • India • Indonesia • Ireland • Israel • Italy • Jamaica • Japan • Jordan • Korea • Kuwait • Lebanon • Malaysia • Mexico • Netherlands • New Zealand • Norway • Pakistan • Peru • Philippines • Poland • Portugal • Puerto Rico • Qatar • Romania • Russia-CIS • Saudi Arabia • Singapore • Slovakia • Slovenia • South Africa, Republic • Spain • Sweden • Switzerland • Taiwan • Thailand • Turkey • United Arab Emirates • United Kingdom • United States • Uruguay • Venezuela • Yugoslavia

Allen-Bradley Headquarters, 1201 South Second Street, Milwaukee, WI 53204 USA, Tel: (1) 414 382-2000 Fax: (1) 414 382-4444

# AB Drives