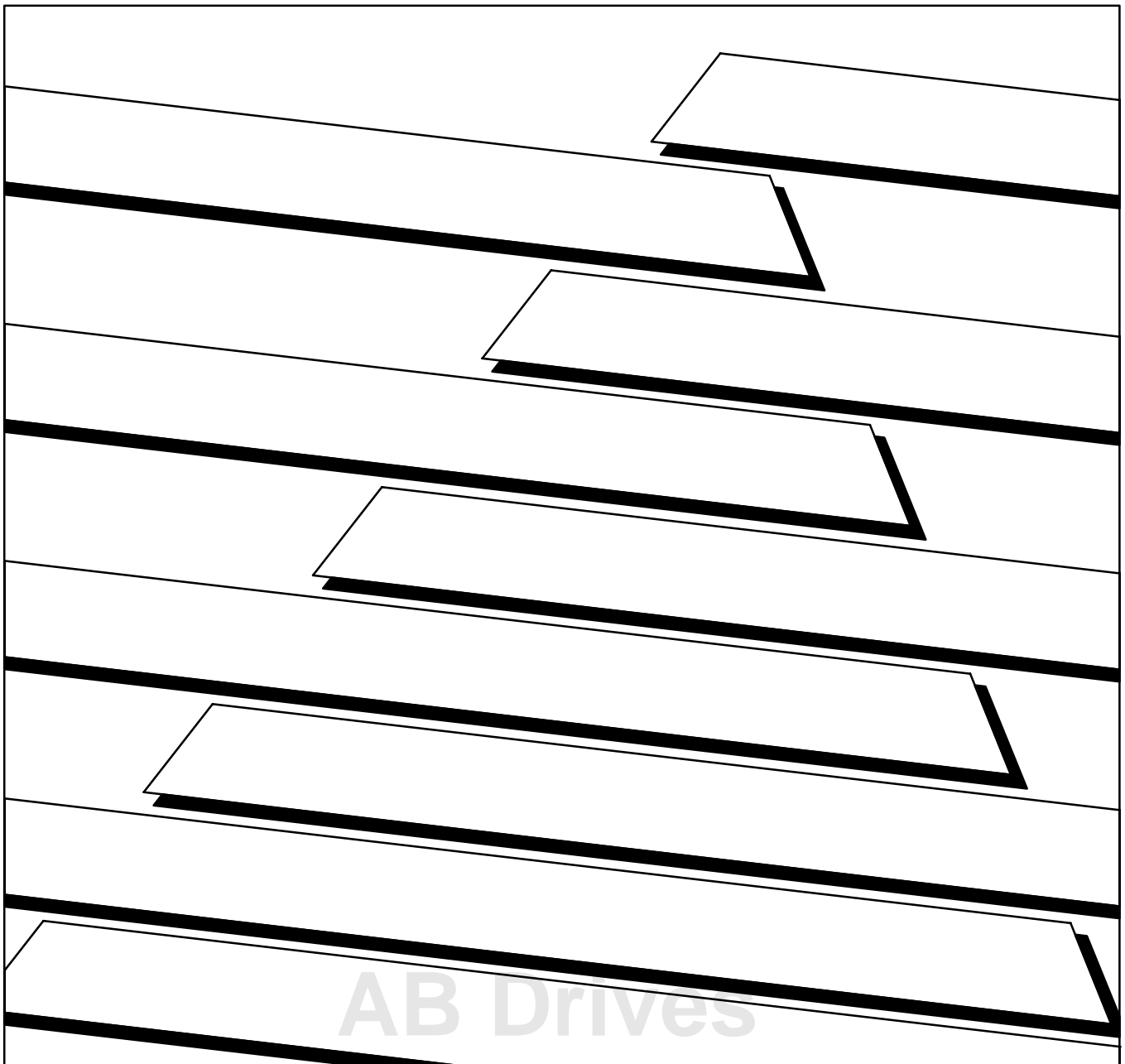


# Bulletin 1772 Mini-PLC-2/15 Programmable Controller

Assembly and Installation Manual



# Table of Contents

---

<b>Introduction</b> .....	<b><a href="#">1-1</a></b>
General .....	<a href="#">1-1</a>
PC Definition .....	<a href="#">1-1</a>
Fundamental Concepts .....	<a href="#">1-1</a>
Pre-Assembly & Installation .....	<a href="#">1-2</a>
<b>Controller Components</b> .....	<b><a href="#">2-1</a></b>
General .....	<a href="#">2-1</a>
System Power Supply .....	<a href="#">2-3</a>
I/O Chassis .....	<a href="#">2-7</a>
Mini-PLC-2/15 Processor .....	<a href="#">2-8</a>
Input/Output Modules .....	<a href="#">2-11</a>
Industrial Terminal .....	<a href="#">2-14</a>
User-Supplied Equipment .....	<a href="#">2-14</a>
<b>Assembly and Installation</b> .....	<b><a href="#">3-1</a></b>
General .....	<a href="#">3-1</a>
System Installation Recommendations .....	<a href="#">3-1</a>
General Grounding Information .....	<a href="#">3-8</a>
Chassis Pre-Assembly .....	<a href="#">3-11</a>
I/O Chassis and Power Supply Mounting .....	<a href="#">3-17</a>
I/O Chassis Assembly .....	<a href="#">3-18</a>
Wiring/Cabling Installation .....	<a href="#">3-25</a>
Incoming AC Wiring Guidelines .....	<a href="#">3-33</a>
Industrial Terminal Installation .....	<a href="#">3-37</a>
<b>System Start-Up</b> .....	<b><a href="#">4-1</a></b>
Start-Up .....	<a href="#">4-1</a>
Checkout Before Applying Power .....	<a href="#">4-1</a>
Checkout With Power Applied To Selected Devices .....	<a href="#">4-2</a>
Checkout of Machine Motion .....	<a href="#">4-7</a>
<b>Maintenance and Troubleshooting</b> .....	<b><a href="#">5-1</a></b>
General .....	<a href="#">5-1</a>
Preventive Maintenance .....	<a href="#">5-1</a>
Spare Parts .....	<a href="#">5-1</a>
Troubleshooting .....	<a href="#">5-1</a>
System Power Supply .....	<a href="#">5-2</a>
Mini-PLC-2/15 Processor .....	<a href="#">5-11</a>
1771 I/O Modules .....	<a href="#">5-14</a>

<b>Specifications</b> .....	<b><a href="#">6-1</a></b>
General .....	<a href="#">6-1</a>
Mini-PLC-2/15 Processor .....	<a href="#">6-1</a>
System Power Supply .....	<a href="#">6-2</a>
I/O Equipment .....	<a href="#">6-3</a>
Industrial Terminal .....	<a href="#">6-3</a>

## Introduction

### General

The Bulletin 1772 Mini-PLC-2/15 Programmable Controller is a digital, electronic, solid state industrial programmable controller capable of monitoring and controlling up to 128 I/O devices. The Controller has a Processor, a power supply and a number of user-selected I/O Modules chosen for the number and type of I/O devices in the user's application. By selecting the appropriate modules, the user can assemble a complete programmable controller system to meet the application requirements.

The Processor and the selected I/O Modules are housed in a single I/O Chassis, which can be mounted inside an enclosure with a working depth of 8 inches.

### PC Definition

A programmable controller (PC) is a solid state logic control device used for industries as diverse as petrochemical, food processing, pulp and paper, mining, steel and metals, and cement to name a few.

As the term "programmable" implies, PC memory can be readily changed to meet application needs.

### Fundamental Concepts

The Controller continuously monitors the status of devices connected as inputs. Based on input device status and the User Program, the Controller controls the devices connected as outputs. These input and output devices may be of different types with various voltage and current ranges. They may include:

- limit, float, selector, and pressure switches
- pushbutton switches
- thumbwheel switches
- alarms, indicators, and annunciator panels
- solenoids
- motors and motor starters
- transducers
- various solid state devices, including TTL and Analog instrumentation

The Processor stores all I/O device status data in a central read/write memory. This allows the latest status data to be accessible during the scanning of the user program. PC programming instructions allow the Processor to perform:

- Timing/Counting operations
- Arithmetic (+, -, x, :) operations
- Data transfers and comparisons
- Program Jumps/subroutines
- Word/File transfers
- Sequencer operations
- Block transfer operations
- Data highway communication

The Mini-PLC-2/15 Programmable Controller uses readily understandable symbols in a ladder diagram format. The ladder diagram program is manually entered into memory using an Industrial Terminal. An Industrial terminal is also used to edit the program and monitor the status of the user's I/O devices as well as interface the Mini-PLC-2/15 Processor with a peripheral device. Peripheral devices including keyboards/printers, the Digital Cassette Recorder (Cat. No. 1770-SA) and the Data Cartridge Recorder (Cat. No. 1770-SB) allow a variety of additional capabilities:

- loading/storing/verifying the program using magnetic tape
- generating a hard-copy printout of the ladder diagram program or total memory
- generating various types of reports in a user-programmed format

Indicators on the various Controller components are used to show I/O device, Processor, and power supply status. These indicators help to diagnose a fault situation quickly when troubleshooting the PC system.

## **Pre-Assembly & Installation**

Read this manual carefully before assembling or installing any component. It is strongly recommended that the hardware and installation personnel work closely with the Mini-PLC-2/15 programmer at start-up.

Certain aspects of the programmable controller may be new to many individuals. For this reason, Publication SG1-1.1, "Application Considerations for Solid State Controls" should be read, as it provides general background information on solid state controls.

**WARNING:** To avoid personal injury and equipment damage, completely read and thoroughly understand the contents of this Manual before attempting to assemble and install the Mini-PLC-2/15 Controller and/or any of its components.

## Controller Components

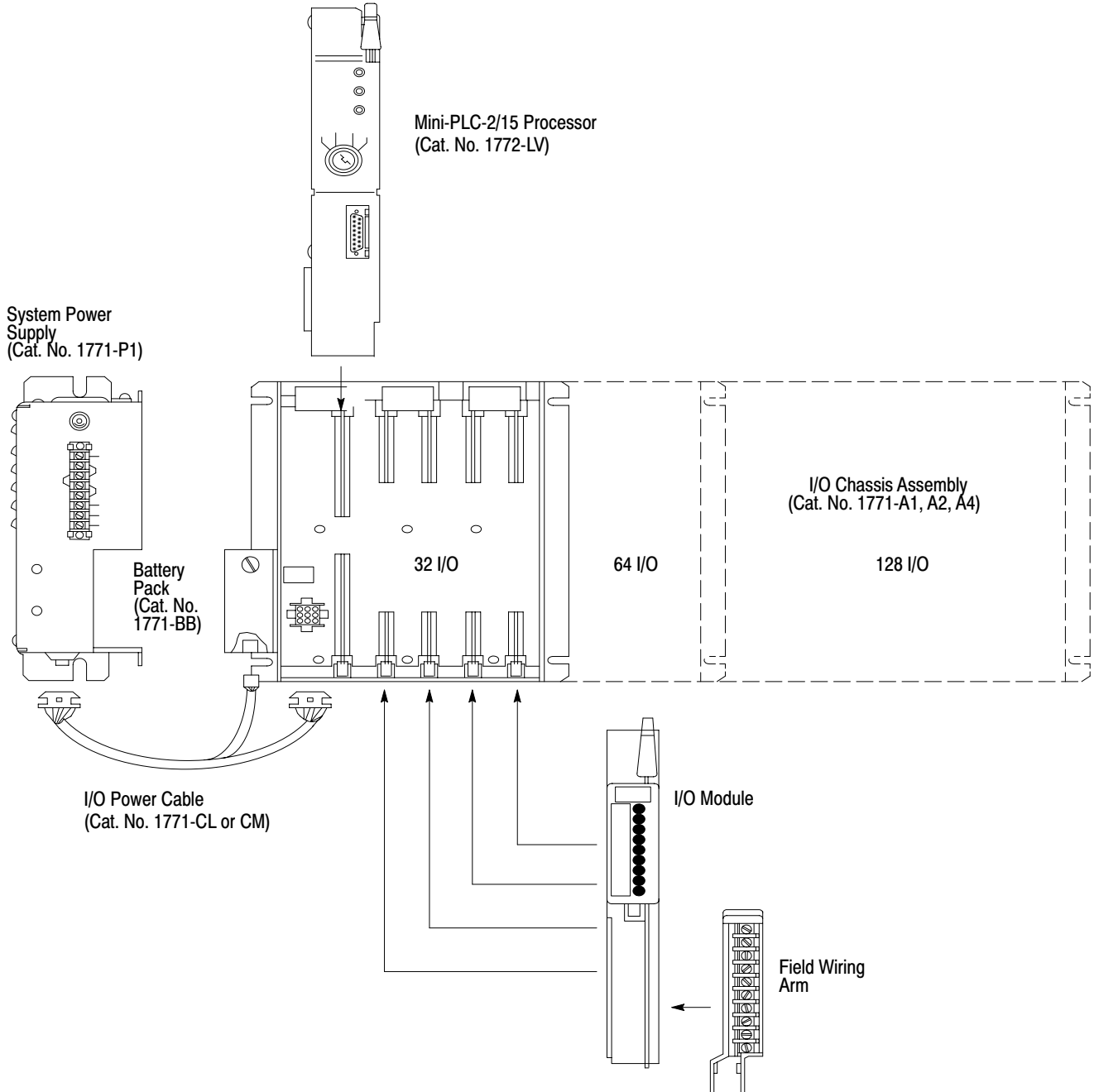
### General

The Mini-PLC-2/15 Programmable Controller (Figure 2.1) is made up of the following major components:

- System Power Supply(Cat. No. 1771-P1)
- I/O Chassis (Cat. No. 1771-A1, -A2 or -A4)
- Mini-PLC-2/15 Processor Module (Cat. No. 1772-LV)
- A number of Bulletin 1771 I/O Modules.

Each of these components and their associated cables must be specified by the user when ordering the Mini-PLC-2/15 Programmable Controller. This section will identify and describe the hardware associated with each of these Mini-PLC-2/15 Controller components. This will enable the user to assemble and install the components as described in Chapter 3. For additional information, refer to the respective Product Data Sheet for the component.

**Figure 2.1**  
**Mini-PLC-2/15 Programmable Controller Components**



## **System Power Supply**

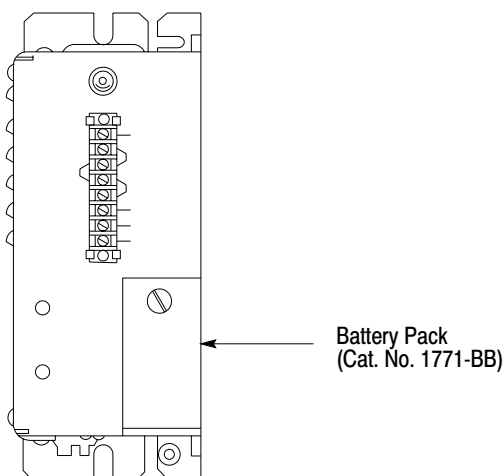
The System Power Supply (Cat. No. 1771-P1) is the required power source for the Mini-PLC-2/15 Controller (Figure 2.1). It converts the incoming AC voltages into the proper DC voltages to power the Processor and I/O Modules.

The System Power Supply can operate on either 120V AC or 220/240V AC. It provides a regulated output of 5.1V DC to power the logic circuitry of the Processor and I/O Modules. It also provides 5V DC for the memory circuitry of the Processor module.

The 5.1V output provides a maximum current of 6.5 amperes for the Processor and I/O Modules. Thus, the current requirements of the selected I/O Modules and Processor Module added together cannot exceed 6.5 amperes. The current requirements for available modules are listed in Table 1.A.

The System Power Supply is protected against undervoltage, overvoltage and overcurrent conditions. It constantly monitors the incoming AC voltage for proper levels (98 to 132V AC for 120V AC operation; 196 to 250V AC for 220/240V AC operation). The power Supply allows some margin for variation from this normal voltage range. There is a minimum voltage of 92V for 120V AC operation and 184V for 220/240V AC operation. If the AC line voltage drops below the minimum voltage for more than one-half cycle, the Power Supply signals the Processor to stop communication with the I/O Modules before invalid I/O data is transmitted. Once the correct AC level returns, communication with the I/O Modules is re-established.

**Figure 2.2**  
**System Power Supply**



10694-I



### **Battery Pack**

The Battery Pack (Cat. No. 1771-BB) is shipped standard with the System Power Supply and consists of:

- A metal Battery Housing (Cat. No. 1771-BH)
- A mounting Hardware Set (Cat. No. 1771-BX)
- Two D-size alkaline batteries (Cat. No. 1771-BA)

An optional lithium battery (Cat. No. 1770-XO) can be ordered for use with the Battery Pack, is preferred.

The Battery Pack provides a convenient form of RAM memory backup power to the Processor when power from the System Power Supply is interrupted. It provides this memory backup power when the Processor is seated in the left-most slot of the I/O chassis. An external Battery Pack can also maintain memory content when the Processor is removed from the I/O Chassis. This is done by connecting them together with the Mini-Processor Transport Cable (Cat. No. 1772-CD) as shown in Figure 2.3.

### **I/O Power Cable**

An I/O Power Cable (Figure 2.1) is used to connect the System Power Supply and the Battery Pack to the I/O Chassis. To accommodate two Power Supply mounting configurations, this cable is available in two lengths:

- Cat. No. 1771-CL I/O Power Cable (1 ft/30.5 cm)
- Cat. No. 1771-CM I/O Power Cable (5 ft/1.5 m)

**Table 1.A**  
**Module Reference Chart**

Module	Cat. No.	Module's Load on System Power Supply	Keying Band Positions Between Nos.	Field Wiring Arm (Cat. No. 1771- )	Color-Coded Label
AC/DC (120V) Input	1771-IA	74mA	4-6, 10-12	-WA	Red
DC (12-24V) Input	1771-IB	74mA	4-6, 14-16	-WA	Blue
DC (48V) Input	1771-IC	74mA	4-6, 16-18	-WA	Blue
Isolated AC/DC (120V) Input	1771-ID	50mA	4-6, 28-30	-WD	Red
Analog (8 bit) Input	1771-IE	400mA	4-6, 26-30	-WB	Pink
Analog (12 bit) Input	1771-IF	1.3A	6-8, 22-24	-WB	Pink
			4-6, 32-34	-WB	Pink
TTL Input	1771-IG	122mA	4-6, 34-36	-WC	Pink
DC (24-28V) Input	1771-IH	74mA	4-6, 16-18	-WA	Blue
Encoder/Counter (5V)	1771-IJ	1.4A	6-8, 18-20	-WB	Brown
			4-6, 32-34	-WB	Brown
Encoder/Counter (12-24V)	1771-IK	1.4A	6-8, 20-22	-WB	Brown
			4-6, 32-34	-WB	Brown
AC/DC (220/240V) Input	1771-IM	75mA	6-8, 30-32	-WA	Red
DC (5-30V) Selectable Input	1771-IQ	150mS	6-8, 24-26	-WC	Blue
Fast Response DC (12-24V) Input	1771-IT	74mA	6-8, 32-34	-WA	Blue
DC (12-24V) Driver Logic Input	1771-IV	74mA	8-10, 12-14	-WA	Blue
Thermocouple Input	1771-IX	2.0A	8-10, 18-20		Blue
			8-10, 20-22	-WE	Pink
Thermocouple Input Expander	1771-IY	500mA	8-10, 20-22	-WE	Pink
AC (120V) Output	1771-OA	210mA	4-6, 12-14	-WA	Orange
DC (12-24) Output	1771-OB	165mA	4-6, 18-20	-WA	Green
DC (48V) Output	1771-OC	165mA	4-6, 20-22	-WA	Green
Isolated AC (120V) Output	1771-OD	225mA	4-6, 30-32	-WD	Orange
Analog (12 bit) Output	1771-OF	1.4A	2-4, 6-8		Yellow
			4-6, 32-34	-WB	Yellow
TTL Output	1771-OG	168mA	6-8, 10-12	-WC	Gray
AC (220/240V) Output	1771-OM	225mA	6-8, 28-30	-WA	Orange
Contact Output	1771-OY	420mA	6-8, 16-18	-WD	Orange
Gray Encoder Input (8 bit)	1771-DL	120mA	4-6, 24-26	-WB	Brown
Mini-PLC-2/15 Processor	1772-LV	2.0A	40-42, 54-56		
Communication Adapter	1771-KA	1.2A	4-6, 22-24		
Communication Controller	1771-KC	1.2A	6-8, 12-14		
Communication Controller	1771-KD	1.2A			
Data Highway Interface/Modem	1771-KF	1.2A			
Modem Interface	1771-KG	1.0A			
			4-6, 22-24		

### AC Input Fuse

A slow-blow fuse (Figure 2.2) is used to guard against overcurrent conditions on the AC input line. The Power Supply is shipped with a 1-amp fuse in the fuse holder for 120V operation. For 220/240V operation, a 0.5-amp fuse is required and is included with the Power Supply.

### Terminal Strip

AC input connections are made to the terminals on the Power Supply labeled L1 and L2. L1 is the high side of the AC line and L2 is the low side (Figure 2.2).

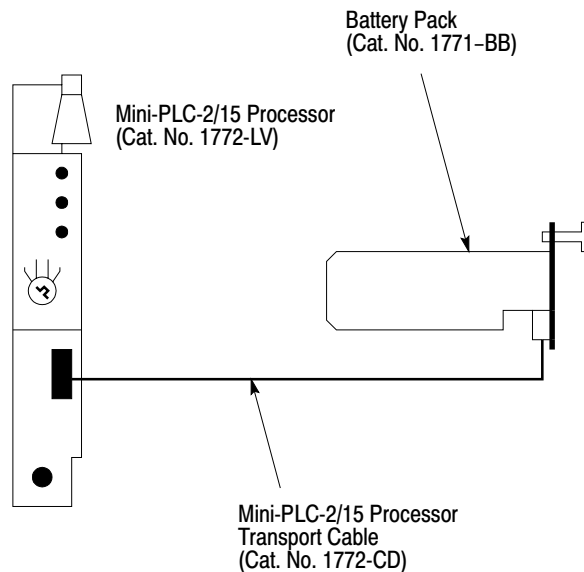
### Power Supply Indicators

The two indicators on the front of the System Power Supply (Figure 2.2) are:

- DC ON
- BATTERY LOW

The red DC ON indicator illuminates when the System Power Supply is operating properly; that is, the AC line voltage and DC output voltages are within their normal ranges. If this indicator is OFF, the incoming AC voltage may be low, the AC line fuse may have blown, or the Power Supply may have overloaded or been shorted.

**Figure 2.3**  
**External Battery Backup**



10105-1

In some “brownout” situations, it is possible that the DC ON indicator might be illuminated while the Processor is disabled. This is because the Power Supply can supply the output voltage to maintain Processor logic, even through the AC line voltage has dropped below the normal range.

The BATTERY LOW indicator flashes when the Battery Pack voltage is low, the batteries are not installed or they have been installed with incorrect polarity. At this level, the batteries can support Processor memory for approximately one week, however memory content should be checked and reentered if necessary.

### **Optional Power Supply Source**

It is permissible to use the 1771-P2 Auxiliary Power Supply in place of the 1771-P2 System Power Supply. It should be noted, however, that RAM memory will be lost if an AC power loss occurs. One of two cables is used with this power supply:

- 1771-CE Power Cable (1 ft/30.5 cm)
- 1771-CD Power Cable (5 ft/1.5 m)

### **I/O Chassis**

The I/O Chassis is the compact, slotted unit that houses the Mini-PLC-2/15 Processor Module and the I/O Modules. There are three I/O Chassis sizes available (Figure 2.4):

- 32 I/O Chassis (Cat. No. 1772-A2), containing 4 I/O Module slots
- 64 I/O Chassis (Cat. No. 1771-A2), containing 8 I/O Module slots
- 128 I/O Chassis (Cat. No. 1771-A4), containing 16 I/O Module slots

Each I/O Chassis is able to fit into a working enclosure eight inches deep.

I/O Chassis are designed to permit Controller expansion. If a 32 I/O or 64 I/O Chassis is used and more I/O points are needed, a larger Chassis can be installed without rewiring. User wiring is connected to Field Wiring Arms which can be removed from the smaller Chassis and snapped onto the corresponding positions of the larger Chassis. Also, when Field Wiring Arms and I/O modules are placed in corresponding slots on the larger Chassis, the originally programmed addresses of the user I/O device are still valid and need not be changed.

The backplane of the Chassis has sockets for each module, a socket for Power Supply connection and a Switch Group Assembly for determining output response to a fault. Latches on top of the Chassis snap down to hold the modules securely in place and provide labeling for module identification.

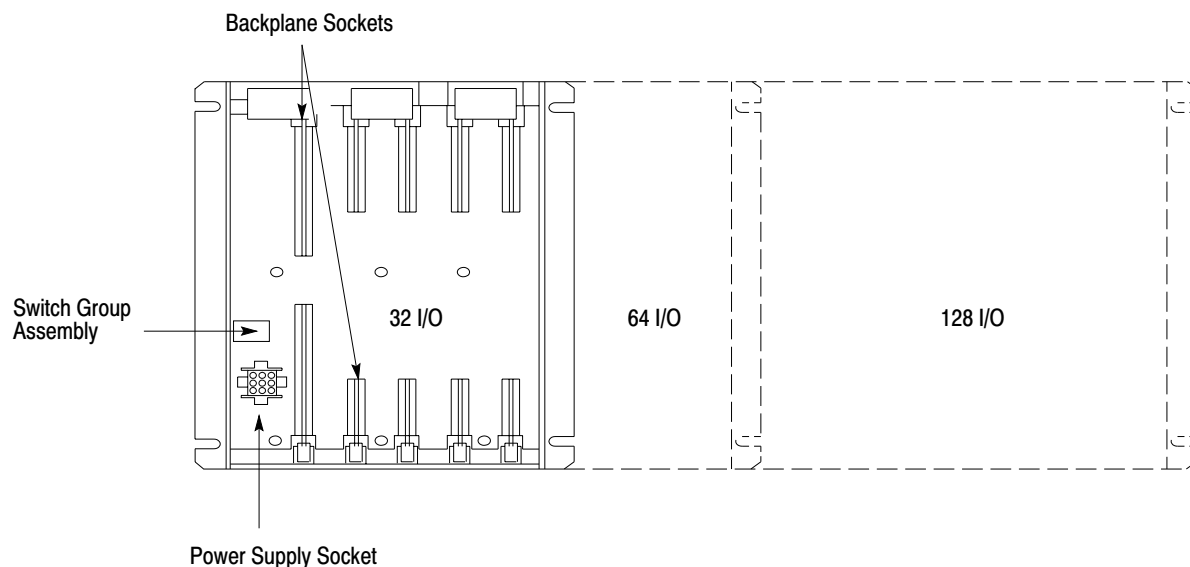
Shipped standard with each I/O Chassis are a number of Field Wiring Arms (Cat. No. 1771-WA), one for each I/O Module slot. If special Field Wiring Arms are required, they are shipped with the I/O Module. In addition, a package of plastic Keying Bands (Cat. No. 1777-RK) is shipped with each I/O Chassis. The Keying Bands provide an easy method for the user to key an I/O Module slot to accept only one type of I/O Module. Use of these keying bands is strongly recommended.

### Mini-PLC-2/15 Processor

The Mini-PLC-2/15 Processor Module (Cat. No. 1772-LV) is the central processing unit and memory of the programmable controller. It has 2K words of memory for the Data Table, User Program and messages. It can monitor and control up to 128 I/O devices that are wired to I/O Modules in the I/O Chassis. The Processor examines data from input devices, processes this data according to the User Program, and transmits data to control the output devices. In addition, the Processor monitors the status of its own operation, of data in memory, and of power from the System Power Supply. Orderly shutdown is provided if a malfunction from any of these points is detected.

The Mini-PLC-2/15 Processor (Figure 2.5) has three diagnostic indicators, a Mode Select Switch, an INTERFACE port and an EPROM access door. In addition, the Processor has a memory write protect feature that is active when a programmed EPROM is in place in the Processor.

**Figure 2.4**  
**I/O Chassis Sizes**



10106-I

### Diagnostic Indicators

There are three diagnostic indicators on the front of the Processor to show the status of its operation (Figure 2.5). They are:

- **PROCESSOR** - When the Mode Select Switch is in the TEST, RUN or RUN/PROG position, this red indicator illuminates if a hardware fault in the Processor occurs or the Processor cannot scan the memory.
- **MEMORY** - In the TEST, RUN or RUN/PROGRAM mode, this red indicator illuminates if the Mini-PLC-2/15 Processor detects no user

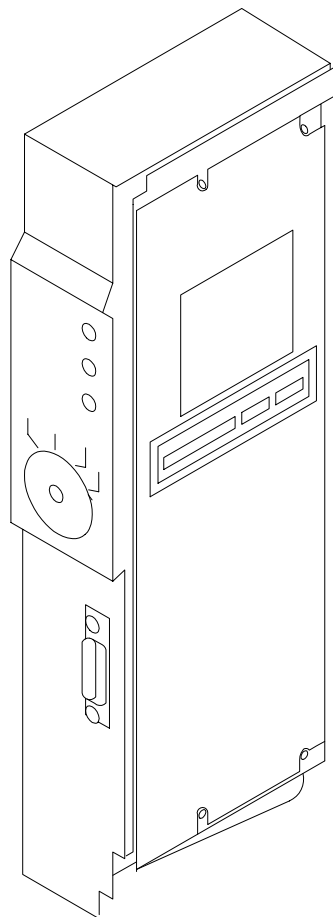
memory, a discrepancy in memory data, or a parity error. This indicator is normally OFF.

In the PROGRAM mode this red indicator is used during EPROM programming. While EPROM programming is in progress, this indicator will blink ON and OFF. When EPROM programming has been successfully completed without error, this indicator will stay OFF. If an error in EPROM programming occurs, this indicator will come ON and stay ON.

This indicator will also flash if EPROM transfer at power-up is bad.

- RUN - This green indicator illuminates when the Mini-PLC-2/15 Processor is operating with the Mode Select Switch in the RUN or RUN/PROG position and the outputs are enabled.

**Figure 2.5**  
**Mini-PLC-2/15 Processor**



10695b-1

### **Mode Select Switch**

The Mode Select Switch (Figure 2.5) places the Processor in one of four operating modes:

- **PROG** - This switch position places the Processor into the PROGRAM mode of operation. The User Program instructions are entered into memory in this switch position. EPROMs are programmed in this mode. All output devices are disabled. When a programmed EPROM is already in place, this mode is limited by the Memory Write Protect feature. See section titled Memory Write Protect for details.
- **TEST** - This switch position allows the User Program to be tested by enabling inputs but not outputs. This allows debugging of the User Program.
- **RUN** - This switch position allows the Processor to scan and execute the User Program. Changes to the Data Table or User Program are not permitted in this switch position. Output devices will be energized according to the User Program.
- **RUN/PROG** - This switch position allows the Processor to function as it does in the RUN position. On-line changes to the Data Table or User Program are permitted in this switch position. When a programmed EPROM is already in place, this mode is limited by the Memory Write Protect feature. See section titled Interface Socket for details.

When the keyswitch is in the RUN/PROG position, the Processor can be placed in one of three remote modes from the 1770-T3 Industrial Terminal keyboard:

- **REMOTE RUN/PROGRAM** - the default mode. When the keyswitch is turned to the RUN/PROG position, the Processor automatically enters this mode. On-line changes to the program and Data Table are allowed in this mode. When a programmed EPROM is already in place, this mode is limited by the Memory Write Protect feature. See section titled Interface Socket for details.
- **REMOTE PROGRAM** - identical to the PROGRAM mode. The program scan and I/O scan will be halted. All outputs are disabled. Going into this mode from REMOTE RUN/PROGRAM will reset an I/O fault, and clear a memory parity error.
- **REMOTE TEST** - identical to the TEST mode. The program scan will be running, but all outputs are disabled. Going into this mode from REMOTE RUN/PROGRAM will reset an I/O fault as does physically changing the keyswitch position from RUN/PROG or RUN to TEST.

### **INTERFACE Socket**

The 15-pin socket labeled INTERFACE is used in connecting the Processor to the Industrial Terminal (Cat. No. 1770-T3) for programming, report generation or monitoring. This socket is also used to connect an external Battery Pack to the Processor so the Processor can be removed from the I/o Chassis without loss of memory. When programming an EPROM this INTERFACE socket is used to connect the 25.5V Power Supply to the Processor.

### **EPROM Access Door**

The EPROM Access Door on the side of the Processor covers a 28-pin EPROM socket, which is used to house an optional 24-pin EPROM memory chip (Erasable Programmable Read Only memory) (Cat. No. 1770-XP). The EPROM provides the user with a 2K word non-volatile memory backup system. Programmed EPROMs can be erased with an ultraviolet light as described in Publication 1770-915, EPROM Programming.

### **Memory Write Protect**

When a programmed EPROM is in place in the Processor, a Memory Write Protect feature becomes active. This means values from word address 2008 to the end of memory are protected and cannot be altered by programming.

## **Input/Output Modules**

The I/O Modules (Figure 2-6) contain the necessary circuitry to interface the user's I/O devices to the Mini-PLC-2/15 Processor.

Each I/O circuit has optical isolation to guard against high-voltage transients that can damage the Mini-PLC-2/15 Controller's logic circuitry. Optical isolation is rated at 1500V RMS.

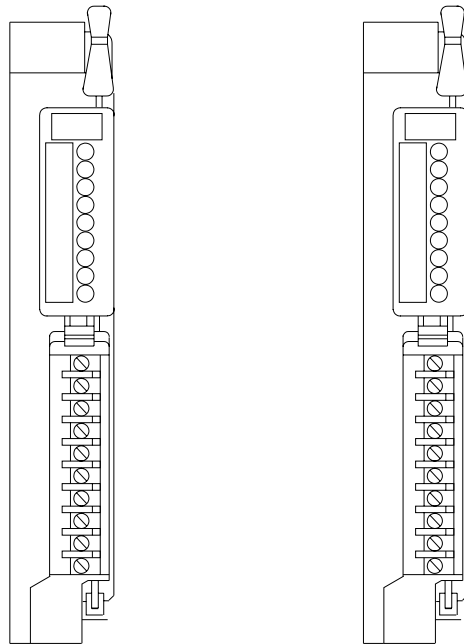
Many Input Modules have filtering circuitry to suppress contact bounce and to guard against recognition of transients as data.

Most I/O modules have indicators that show the ON/OFF status of each input or output device connected to it. These indicators are useful during start-up, monitoring, and troubleshooting. Output modules with fuses also have an additional indicator that illuminates if an output fuse in the module has blown.

I/O modules are available for devices with different voltage levels and characteristics. A color-coded label on each I/O module identifies the general type of module and voltage range. Table 1.A lists the general information on each I/O Module and the Processor Module. The Product Data Sheets for the I/O Modules include a detailed description, Module specifications, connection diagrams and keying information.



**Figure 2.6**  
**Typical Input and Output Modules**



(a) Output Module

(b) Input Module

10841-1

### **Field Wiring Arms**

Wiring to and from user I/O devices connects to a separate Field Wiring Arm for each I/O module. The Field Wiring Arm is a terminal strip that pivots up and down for quick, easy insertion and removal of I/O modules (Figure 2.7) without disturbing filed wiring. This aids in start-up and troubleshooting by shortening the time needed to replace I/O modules, thus decreasing down-time.

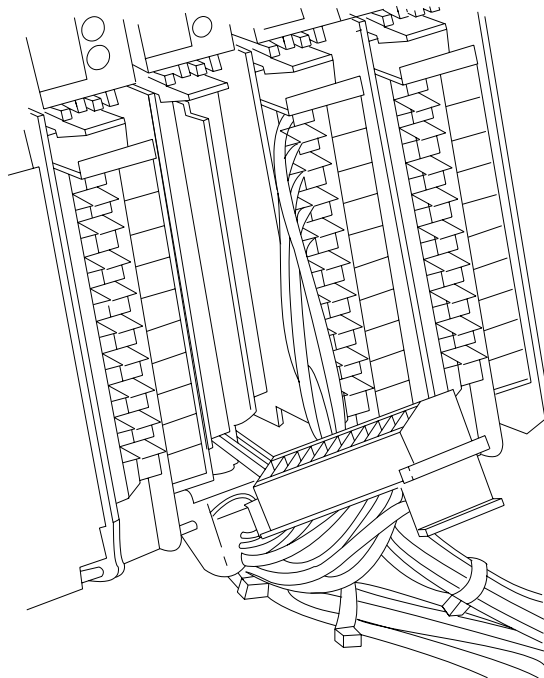
Cat. No. 1771-WA Field Wiring Arms are shipped with the I/O Chassis (one for each I/O Module slot). This Field Wiring Arm is used with most I/O modules. If a certain module requires a different Field Wiring Arm, it is shipped with that module. In this case, use the Field Wiring Arm that comes with the module.

### **I/O Addressing**

Each terminal on a Field Wiring Arm is identified by a 5-digit address (Figure 2.8). The 5 digits in the terminal address directly correspond to a memory location in the Processor's Data Table and designate the following:

- The first digit is either a 0 for outputs or a 1 for inputs.
- The second digit refers to the Rack Number (always 1 for the Mini-PLC-2/15 System).
- The third digit refers to the Module Group Number (0-7). A Module Group consists of two adjacent I/O Module slots in the I/O Chassis starting at the left (Figure 2.9). The Module Group Numbers for each pair of I/O slots are identified on labels on the Chassis latches.
- The fourth and fifth digits of the address refer to the Terminal number within the Module Group (00-07, 10-17).

**Figure 2.7**  
**Field Wiring Arms**



10767-I

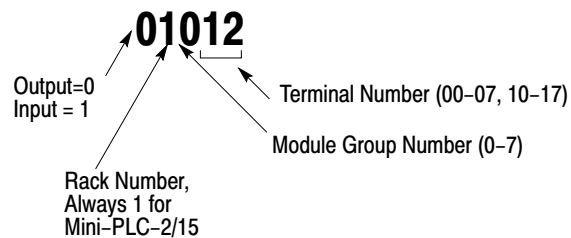
## Industrial Terminal

The Industrial Terminal System (Cat. No. 1770-T3) is used to enter, monitor, edit and troubleshoot the User Program in the memory of the Mini-PLC-2/15 Processor (Figure 2.10). In addition, it can be used for report generation or to interface peripheral devices to the Processor.

The 1770--T1 or -T2 Industrial Terminals can be used with the Mini-PLC-2/15 Processor, however, they will limit the capabilities of the Processor. When using the 1770-T1 or -T2 Industrial Terminal, the Mini-PLC-2/15 Processor will be limited in the following ways:

- Up to 256 word Data Table
- Up to 104 Timers/ Counters
- I/O forcing in one Module Group at a time
- Mini-PLC-2 processor instruction set

**Figure 2.8**  
**Five-digit Address**



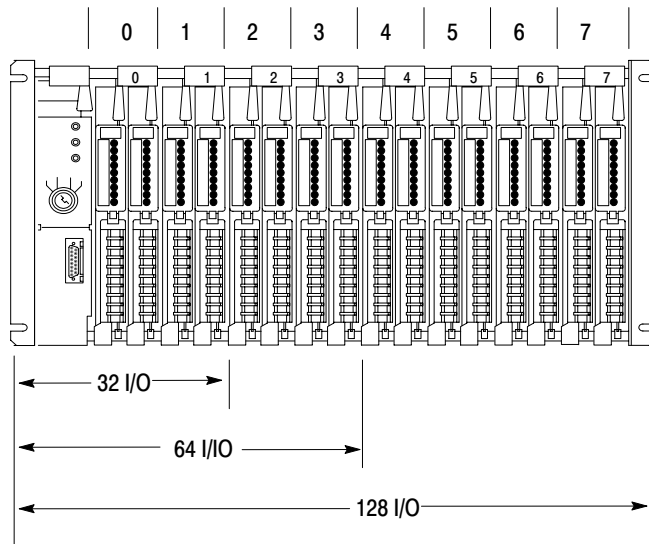
10107-1

## User-Supplied Equipment

In addition to Mini-PLC-2/15 Controller components, the user can supply other equipment for Controller installation including:

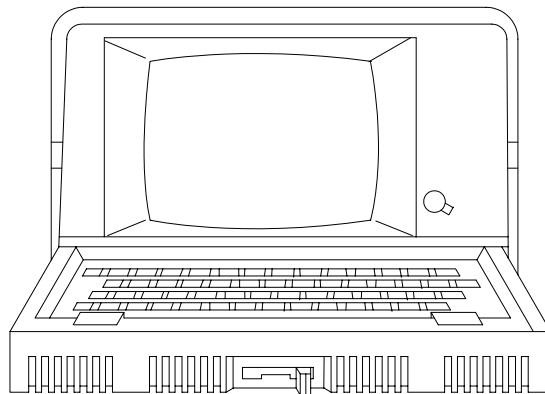
- An enclosure, for mounting the Controller and shielding it from noise and airborne contaminants
- Emergency-Stop switches, variable in type and number
- Master Control Relay, to enable and disable I/O power by manual control
- Disconnects, normally a part of any electrical installation
- Isolation transformers or constant voltage transformers, as application needs dictate
- User power supplies, for I/O devices not powered directly from the AC line
- Suppression devices, for noise-generating equipment, including inductive loads in series with hard contacts

**Figure 2.9**  
**Module Groups**



10108-I

**Figure 2.10**  
**Industrial Terminal (Cat. No. 1770-T3)**



10296-I

## Assembly and Installation

### General

Safety is a primary consideration in programmable controller installations and operations. The procedures in this section consider the safety of the operator, of the controlled equipment and of the Controller. These procedures are intended to supplement the applicable codes and ordinances that govern wiring and installation practices. Personnel installing the Controller system should become familiar with local codes as well as these procedures.

A well-planned layout is essential for the installation of the Mini-PLC-2/15 Controller. Various considerations necessary for planning the installation are discussed in this section.

Once the layout is planned, the Controller components can be assembled and installed into a workable system. The sequence of events presented in this section is a suggested approach to facilitate the assembly and installation of the components.

**CAUTION:** To avoid equipment damage, thoroughly read and understand this entire Manual before installing or operating the Mini-PLC-2/15 Controller.

---

### System Installation Recommendations

There are general recommendations to consider for layout of the Controller system. These recommendations are the result of both product testing and Allen-Bradley's cumulative experience with solid state industrial controls. They provide useful guidelines for most Mini-PLC-2/15 Controller installations.

These recommendations are intended to make the Controller an integral part of the user's manufacturing facility. Some of the installation recommendations for user-supplied equipment are general in nature. Environmental conditions, the individual application and local codes and ordinances dictate the specific types of layout and wiring of user-supplied installation equipment.

### Environmental Considerations

Special care should be taken in industrial environments that may contain one or more conditions adverse to solid state controls. The user's plant may include equipment which produces heat or electrical noise. Line voltage variations may also occur in some locations.

### **EXCESSIVE HEAT**

For most applications, normal convection cooling keeps Controller components within the 0<sup>0</sup> to 60<sup>0</sup>C ambient operating range. Thus, the proper spacing of components within the enclosure is usually sufficient for heat dissipation.

There are however, some applications where a substantial amount of heat is generated by equipment either inside or outside the enclosure. In these cases, blower fans may be placed inside the enclosure to assist air circulation and to reduce “hot spots” near the Controller.

**CAUTION:** Do not bring outside air into the enclosure; it may introduce harmful contaminants or dirt.

---

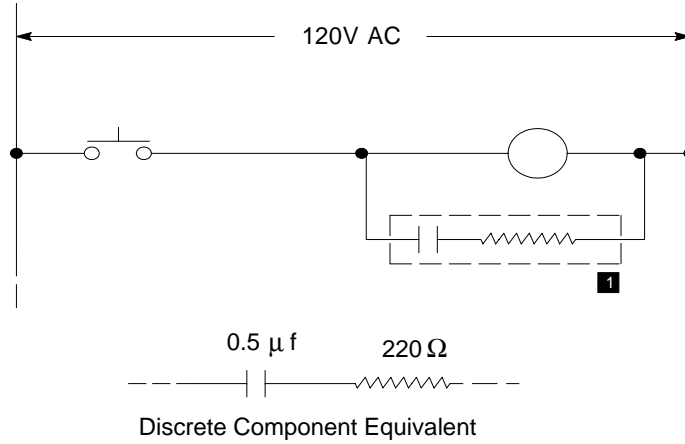
### **ELECTRICAL NOISE**

When the Mini-PLC-2/15 Controller is operating in a “noise-polluted” industrial environment, special consideration should be given to possible electrical noise interference. potential noise generators include inductive loads such as relays, solenoids, motors and motor starters when they are operated by “hard contacts,” such as pushbuttons and selector switches. in the case of reversing motor starters, hard contacts are wired to make each starter electrically as well as mechanically interlocked. In this case, suppression is needed at the device because of the hard contacts in the circuit with the load.

Suppression for noise generators may be necessary when these types of loads are connected as output devices of when connected along the same AC line which brings in power to the Mini-PLC-2/15 Controller.

A suggested electrical noise suppression unit for small AC devices (i.e, relays, solenoids, and starters up to NEMA Size 1) is shown in Figure 3.1. For larger contractors of NEMA Size 2 and above, a parallel varistor for transient voltage limitation is needed in addition to the RC network shown in Figure 3.2 and Figure 3.3. DC relays are suppressed by freewheeling diodes as shown in Figure 3.4.

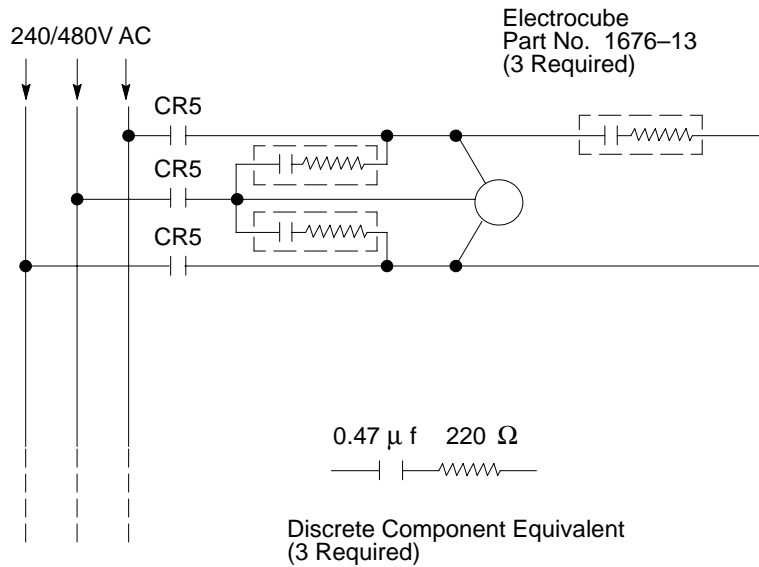
**Figure 3.1**  
**Typical Suppression for Small AC Inductive Load**



- 1 Allen-Bradley surge Suppressors:  
 Cat. No. 1691-N2: General Purpose  
 Cat. No. 599-K04: Bulletin 509 Starters  
 Cat. No. 700-N5, N9 N24: 700 N Relays  
 Cat. No. N10: Bulletin 709 Starters

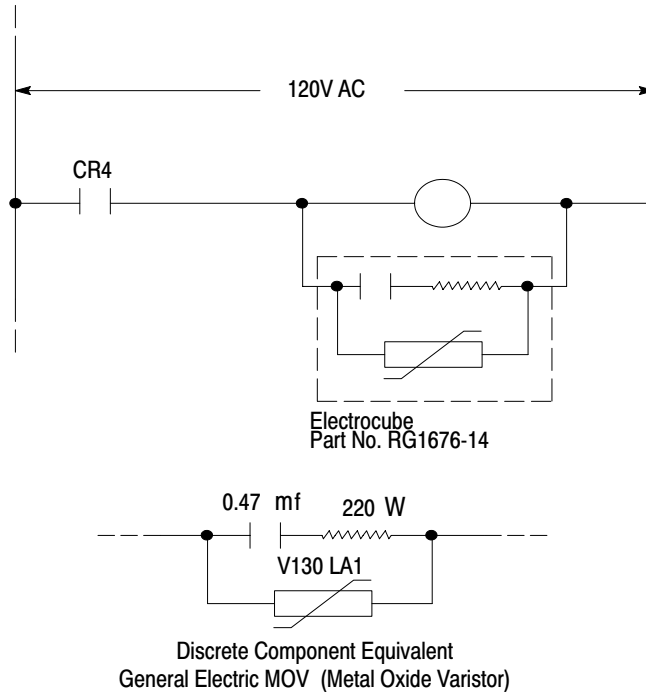
10109-I

**Figure 3.2**  
**Typical Suppression for 3-Phase Inductive Load**



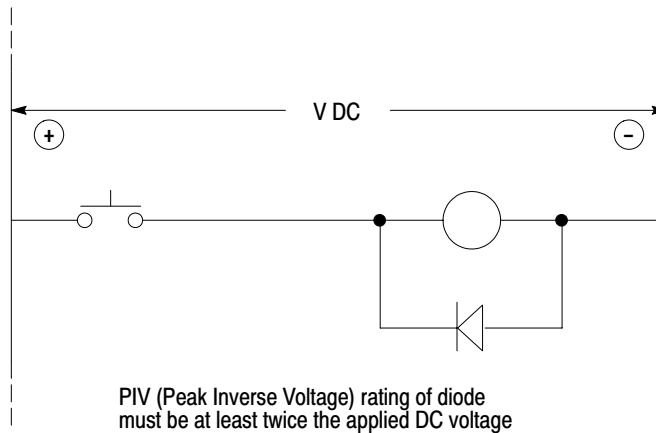
10110-I

**Figure 3.3**  
**Typical Suppression for Large AC Inductive Load**



10111-I

**Figure 3.4**  
**Typical Suppression for Small DC Inductive Load**



10112-I

All possible sources of noise should be suppressed. Best results are achieved when the noise-suppressing networks are connected as closely as possible to the “noisy” device.



## CONSTANT VOLTAGE TRANSFORMER

In applications where the AC line is especially unstable and subject to unusual variation, a constant voltage transformer can be used to stabilize the input voltage to the System Power Supply as well as the input voltage to the user devices.

A constant voltage transformer compensates for voltage changes at its input to maintain a steady voltage at its output. If a constant voltage transformer is required, it must be connected to the System Power Supply and all input devices connected to the Mini-PLC-2/15 Controller. Output devices should be connected on the same AC line, but not necessarily after the constant voltage transformer.

The constant voltage transformer must have a sufficient power rating for its load. The transformer power rating for the System Power Supply should be at least 225VA (volt-ampere).

Determining the proper size transformer must be based on several factors:

1. The user must determine the System Power Supply power requirement from the nameplate or product specifications. The power requirement for the 1771-P1 Power Supply is 75 VA.
2. Determine total power requirement of inputs drawing power from this transformer. Add worst case power requirement of output devices which will also draw power from this transformer. When output devices are connected, the transformer size is substantially increased.
3. Add input device power requirement and output device power requirement (only those connected to the transformer secondary). Multiply the Power Supply VA rating by 3. Add this figure to the input/output device requirement.

These calculations determine the proper transformer size, allowing ample power to be delivered to the Power Supply throughout the entire AC cycle, and provide the necessary power for I/O devices.

NOTE: If the output devices connected to the transformer are motors follow the manufacturer's transformer specifications. Some manufacturers recommend a reserve capacity of 6 to 8 times the motor VA requirement to handle starting current surges.

### **Enclosure Considerations**

An enclosure is usually provided by the user for housing the Mini-PLC-2/15 Controller. The enclosure is the primary means of protecting the Controller from atmospheric contaminants (oil, moisture, conductive dust or particles, or any corrosive or otherwise harmful airborne substance). Standards established by the National Electrical Manufacturer's Association (NEMA) define enclosure types based upon the degree of protection the enclosure provides the components mounted inside. In general, an enclosure which conforms to the NEMA standard for Type 12 enclosures is preferred for solid state control devices.

The enclosure should be mounted in a position which allows the doors to be opened fully and allows access to wiring and components for testing or troubleshooting. Also important is the accessibility to a disconnect device in the enclosure.

The Mini-PLC-2/15 Controller requires a minimum of 8 inches of "working depth" in the enclosure. Working depth is the distance from the rear of the Chassis when mounted in the enclosure to the inner-most surface of the enclosure door when closed. This would take into account print pockets mounted on the door. Carefully examine the vendor's data sheets for print pockets mounted on the door and stand off measurements when calculating the working depth of an enclosure.

### **Component Spacing Considerations**

Mini-PLC-2/15 Controller components must be spaced sufficiently from other equipment and the enclosure walls to allow convection cooling. Convection cooling draws a vertical column of air upward over the Controller module surfaces. To keep the Controller modules within the specified temperature limits, this cooling air, drawn in at the base of the Controller, must not exceed 60°C (140°F). Because of this vertical flow of air, the obstructed vertical spacing above and below the Controller components is important.

The temperature of the air must not exceed 60°C (140°F) at any point immediately below any chassis. The failure rate of the semiconductor devices will increase significantly if the temperature is raised above 60°C.

The temperature will tend to be higher toward the top of the enclosure. Factors which determine the level at which the temperature will be 60°C include the size of the enclosure, the power dissipation within the enclosure, and the temperature of the air outside the enclosure.

The following rules apply to the placement of Mini-PLC-2/15 Controller components in relation to each other. Figure 3.5 and Figure 3.6 illustrate the spacing recommendations for two Power Supply mounting configurations.

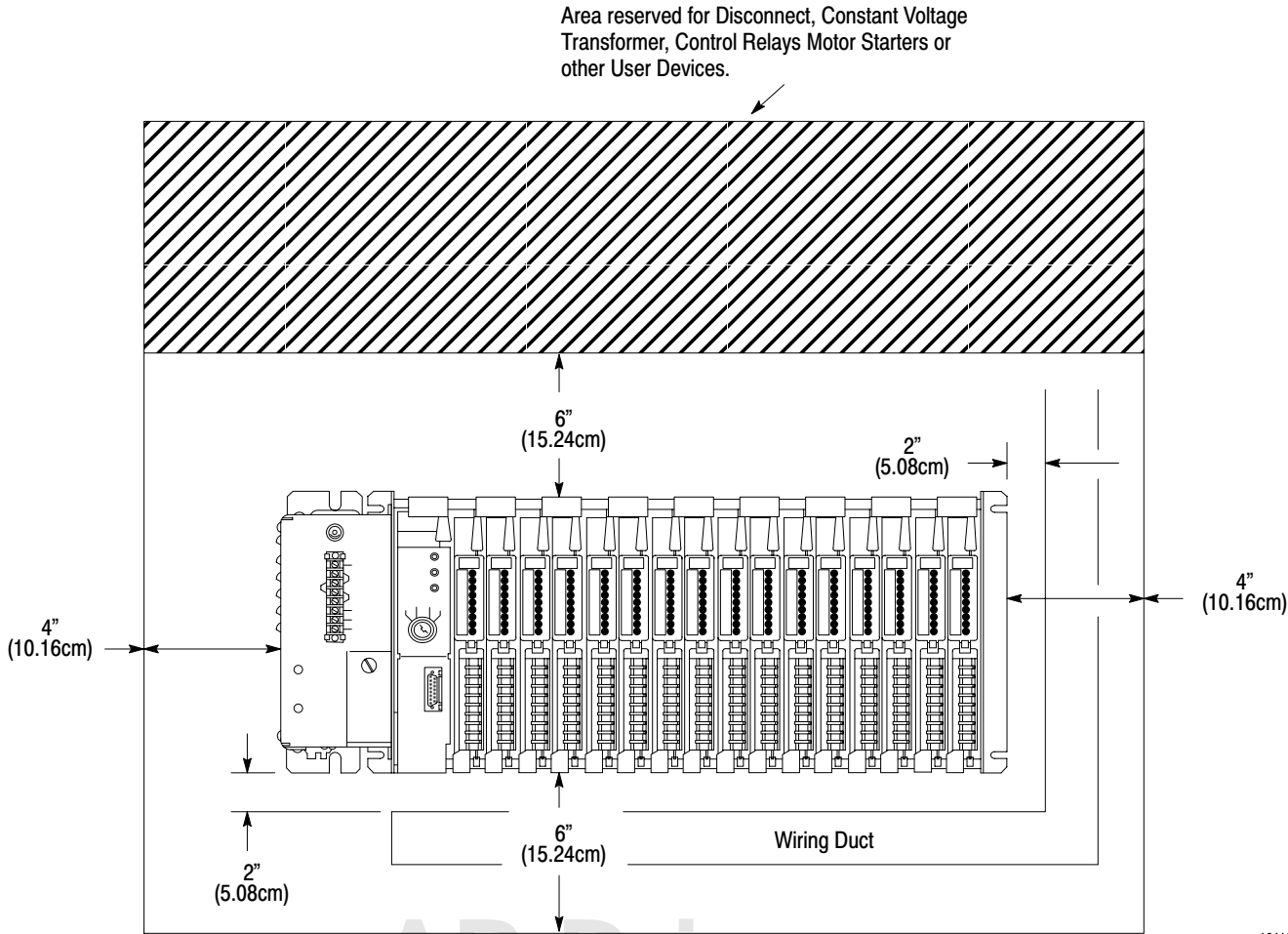
Rule 1 - Allow at least 6 vertical inches above and below all Controller components. when more than one Controller is mounted in an enclosure, allow at least 6 vertical inches between Controllers. Do not mount any component above a 60°C air temperature level.

Rule 2 - Allow at least 4 horizontal inches on the sides of each Controller component. when two or more Controllers are mounted in the same horizontal plane, allow at least 6 horizontal inches between them.

Rule 3 - Allow at least 2 inches between the Controller and the wiring duct or terminal strips.

Rule 4 - When the Power supply is mounted separately, it cannot be mounted below the Processor.

**Figure 3.5**  
**Minimum Component Spacing Requirements (Power Supply Mounted to I/O Chassis)**



**General Grounding  
Information**

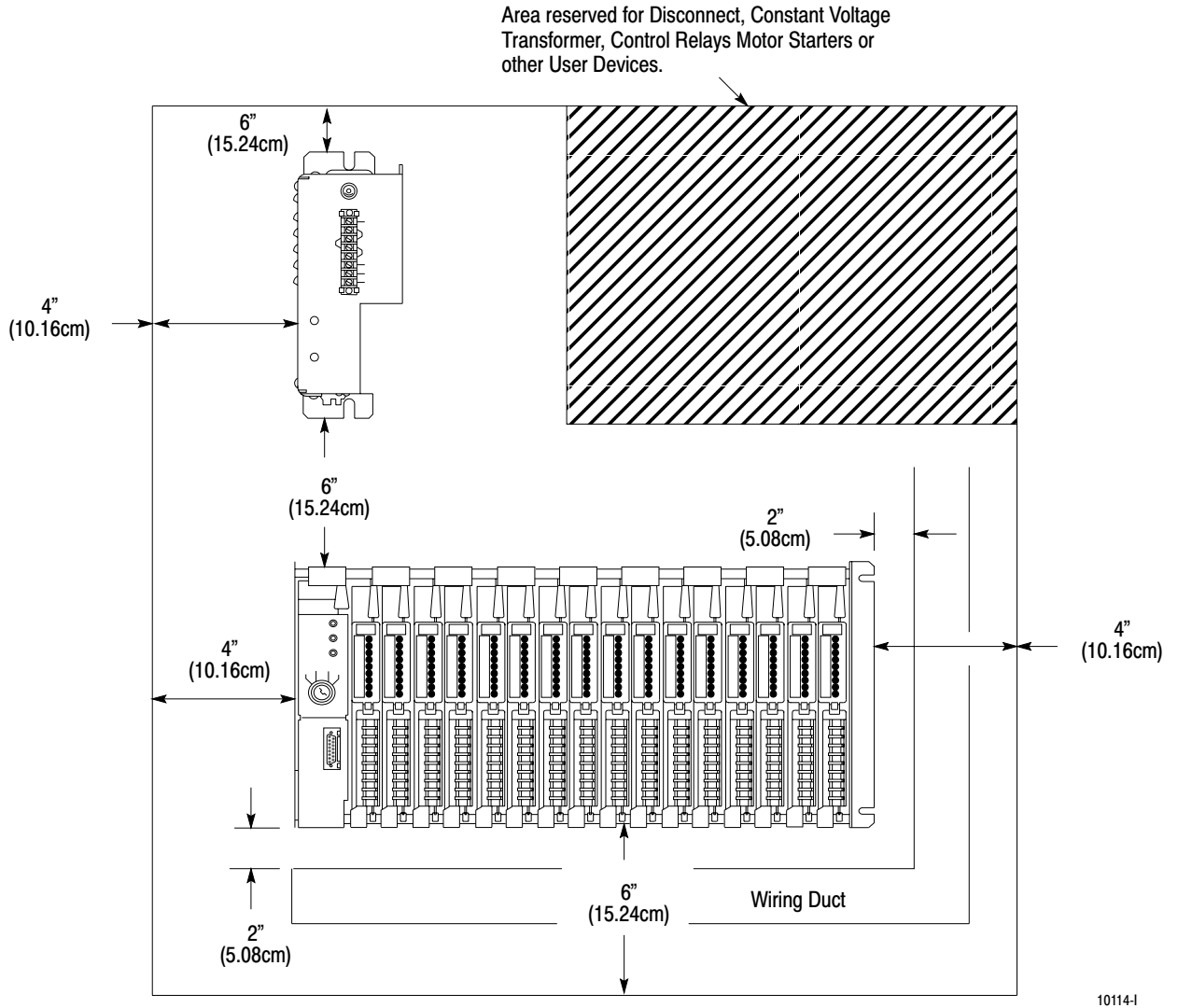
Grounding is an important safety measure in electrical installations. With solid state control systems, grounding has added value because it helps to reduce the effects of noise due to electromagnetic noise interference (EMI).

Allen-Bradley Programmable Controller components and their enclosures must be properly grounded. All applicable Codes and Ordinances should be observed when wiring the Controller.

The grounding path for the Controller components and their enclosures should be provided through a grounding electrode conductor to earth ground, the grounding electrode system. In this document, earth ground is defined as the central ground for all electrical equipment and AC power within any facility. All ground connections must be permanent and continuous to provide a low-impedance path to earth ground for induced noise current and/or fault currents.

An authoritative source for grounding requirements is the National Electrical Code published by the National Fire Protection Association of Boston, Massachusetts. Article 250 of the Code provides such data as the size and types of conductors and methods of safely grounding electrical components. Local Codes and Ordinances dictate which grounding method is permissible. See Publication 1770-980 for a discussion of general grounding and field wiring practices.

**Figure 3.6**  
**Minimum Component Spacing Requirements (Separately Mounted Power Supply)**



10114-I

**PC Component Grounding**

The recommended configuration for grounding Allen-Bradley Programmable Controller components within an enclosure is illustrated in Figure 3.7. Bare metal contact is required to ensure that good electrical contact has been established between Controller components, the enclosure back panel, and the enclosure. Paint or other non-conductive finishes must be scraped from the back panel and Controller components where contact is made with the component mounting bolts, nuts, or welded studs. An 8-gauge copper wire, or larger, should be used to connect each component in the enclosure. Connections should be made to the mounting bolts or studs on only one mounting bracket of the component's chassis (Figure 3.7).

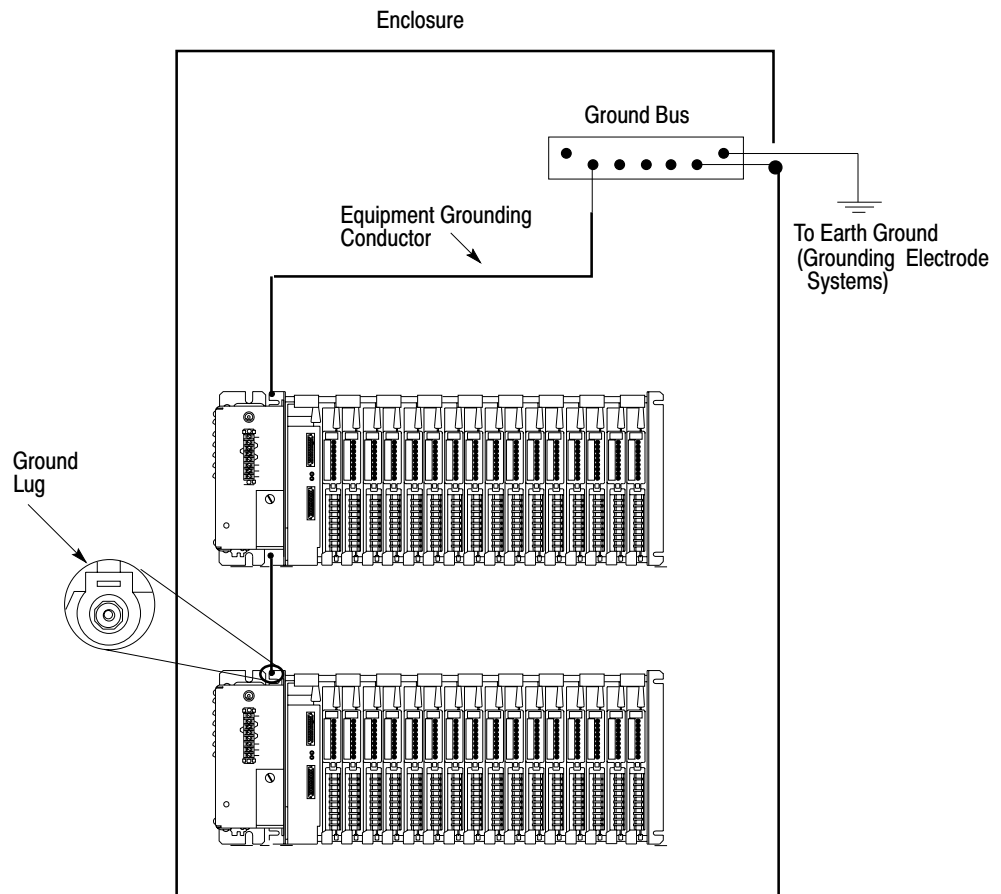
Each vertical group of components is connected together (Figure 3.7) and these groups are connected to a ground bus mounted on the back panel of the enclosure (Figure 3.8 and Figure 3.9). The ground bus is connected to the grounding electrode system through a grounding electrode conductor.

Avoid connecting more than two lugs to a single bolt since the compression of the metal lug can loosen the connection.

### Enclosure Grounding

The enclosure that contains the Allen-Bradley Programmable Controller components must be connected to earth ground (Figure 3.10). Grounding paths to earth ground must be permanent and continuous, and must be able to conduct electromagnetic noise currents and possible ground fault currents safely to earth ground with minimum impedance.

**Figure 3.7**  
Typical Mini-PLC-2/15 Controller Grounding Configuration

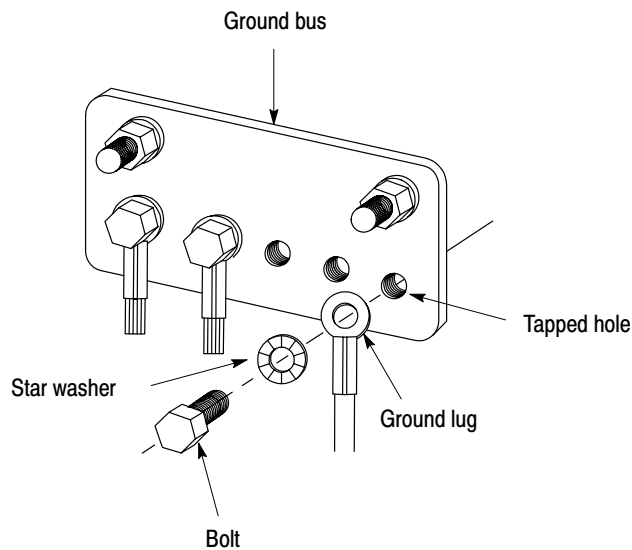


Note: No connection is made to the Equipment Ground Terminal on the Power Supply when this Ground Configuration is used. This could lead to Ground Loops. See incoming AC Wiring Guidelines, Section titled INCOMING AC WIRING GUIDELINES

**Chassis Pre-Assembly**

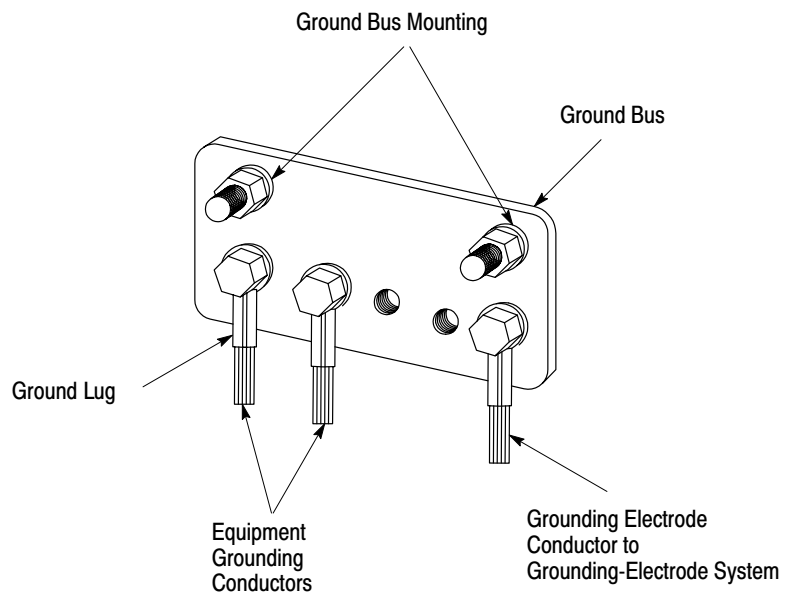
Before the Mini-PLC-2/15 Controller is mounted to an enclosure, the I/O Chassis must be partly assembled. This involves setting the Switch Group Assembly, installing keying bands and installing the Battery Pack. In addition, if the side mounting configuration is used, the System Power Supply should be mounted to the Chassis before the Chassis is mounted to the enclosure back panel.

**Figure 3.8**  
**Ground Bus Connection Details**



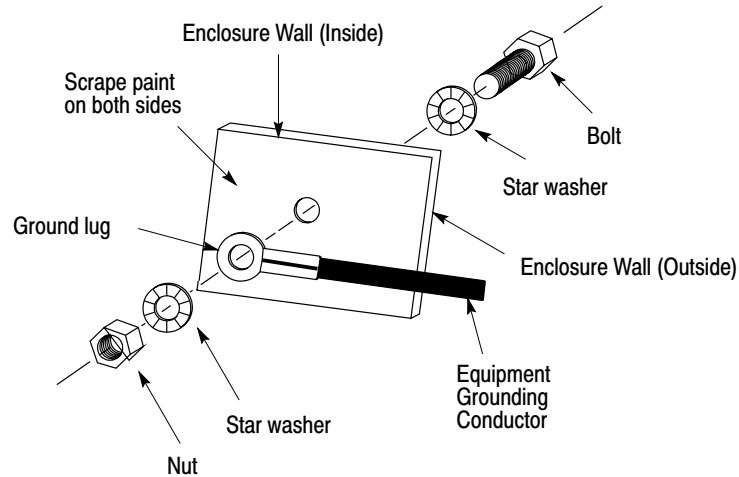
10116-I

**Figure 3.9**  
**Ground Bus Connections**



10117-I

**Figure 3.10**  
**Ground Connections at Enclosure Wall**



10020

### Switch Group Assembly

Located near the lower left side of the I/O Chassis are numbered switches in a Switch Group Assembly (Figure 3.11). Switch 1 must be set ON or OFF to determine output response to a fault. A fault can be considered any malfunction that is detected by the Controller, which causes the operation to shut down. The two switch settings indicate the following (Figure 3.12):

- ON - Outputs are left in their last state, either energized or de-energized, when a fault is detected.
- OFF - Outputs are de-energized when a fault is detected.

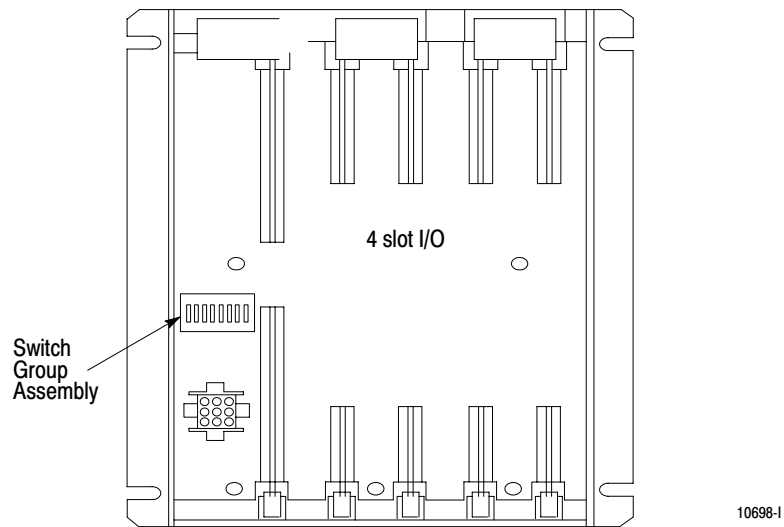
Use the tip of a ballpoint pen to set Switch 1. Do not use a pencil because the tip may break off and jam the switch.

**NOTE:** Switch 1 does not determine output behavior if AC line power fails or if the Processor is placed in the TEST, PROGRAM, REMOTE TEST or REMOTE PROGRAM modes. In these cases, outputs are turned OFF.

Switches 2-8 are not used for the Mini-PLC-2/15 Controller and can have any setting.



**Figure 3.11**  
**Switch Group Assembly**



### **Battery Pack**

The Mounting Hardware Set (Cat. No 1771-BX), which consists of two mounting brackets with screws, is mounted to the left side plate of the I/O Chassis (Figure 3-13). When mounted, the brackets provide tracks on which the Battery Pack slides.

The two alkaline batteries are installed in the Battery Pack (Cat. No. 1771-BB) with the polarity shown in Figure 3-14. It is best to position each battery with the seam facing down in case the batteries leak.

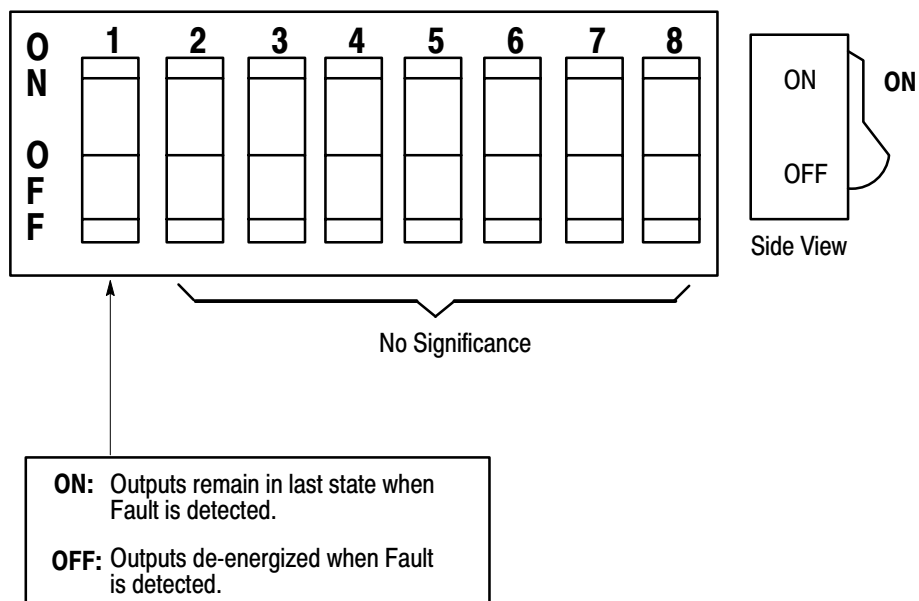
An optional lithium battery (Cat. No. 177-XO) can be installed in the Battery Pack in place of two alkaline batteries. Refer to Publication 1770-950 for lithium battery information. Be sure to follow all cautions associated with these batteries. To use a lithium battery, the battery contacts must be repositioned as follows (Figure 3-15):

- Disconnect the 3-pin connector from the Battery Pack and remove the Battery pack from the I/O Chassis.
- Remove the battery contacts from the center barrier in the Battery Pack.
- Remove the end battery contact (furthest from the front of the Battery Pack) and insert it at center barrier.

- Install one lithium battery in the front battery compartment, seam side down, with the polarity shown in Figure 3-15.
- Reconnect the 3-pin connector at the base of the Battery Pack.

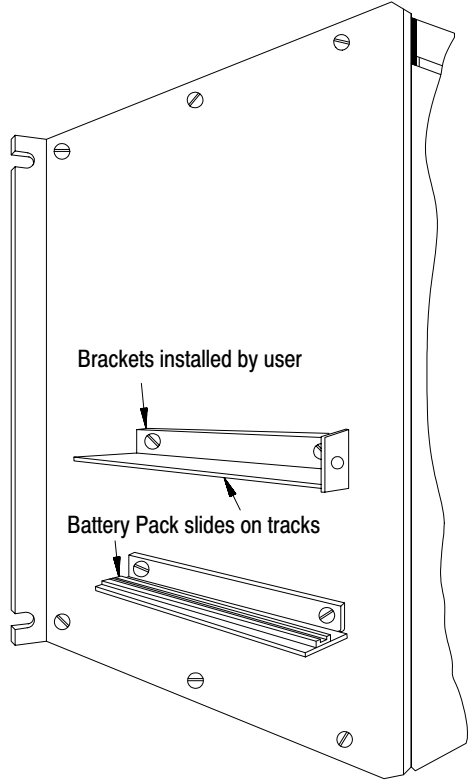
When the batteries are installed, slide the Battery Pack onto the tracks and tighten the thumbscrew.

**Figure 3.12**  
**Switch Group Settings**



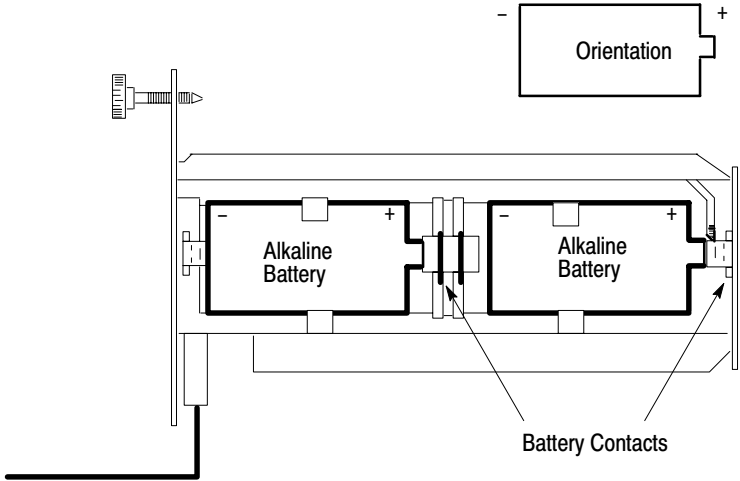
10119-1

**Figure 3.13**  
Mounting Hardware Set



10699-I

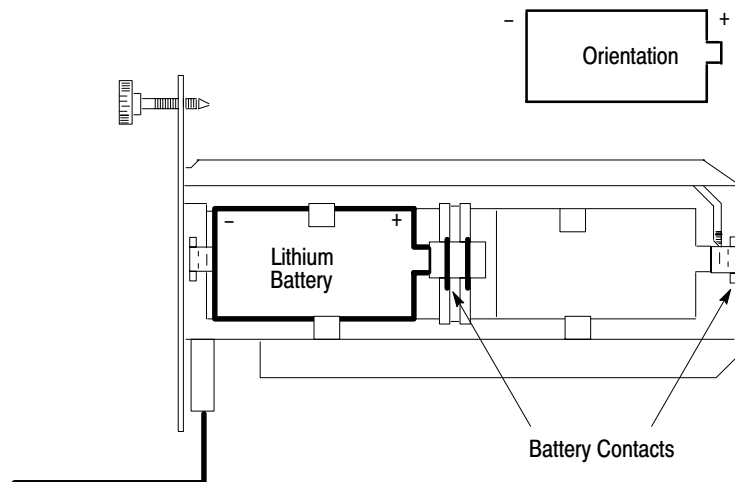
**Figure 3.14**  
Alkaline Battery Installation



10120a-I

10680-I

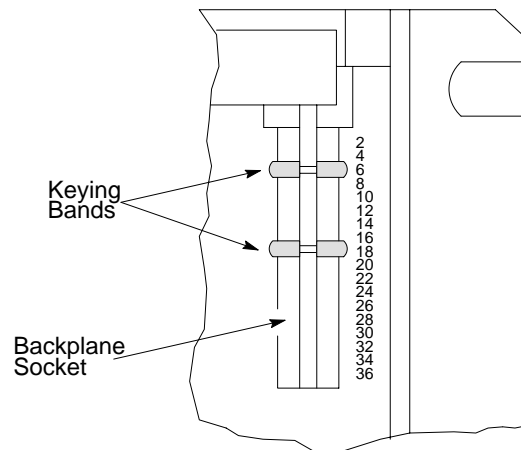
**Figure 3.15**  
**Lithium Battery Installation**



10120b-I

**Figure 3.16**  
**Keying Band Installation**

10680-I



10112-I

### Keying Bands

Plastic keying bands (Cat. No. 1777-RK), shipped with each I/O Chassis, can be inserted into the top backplane sockets of the I/O Chassis (Figure 3.16). They are used to ensure that the correct I/O Modules are installed in the correct Module slots. They are also used to key the Module slot for the Mini-PLC-2/15 Processor. Needle-nose pliers can be used to install the keying bands. The numbers to the right of the backplane sockets serve as a guide for positioning the keying bands. The keying band positions for the 1771 I/O Modules and Processor Module are listed in Table 2-1.

Before installing the keying bands, I/O Module placement with the I/O Chassis must be determined. A general rule of thumb is to group I/O Modules by signal type. For field wiring guidelines and considerations, refer to Section titled Field Wiring Considerations and Field Wiring Guidelines.

### **System Power Supply**

If the side mounting configuration is desired, the System Power Supply and I/O Chassis should be assembled as a unit before mounting to the enclosure for ease of assembly. The Power Supply is mounted to the left side plate of the I/O Chassis with 4 screws.

### **I/O Chassis and Power Supply Mounting**

The Controller components, when mounted, must make solid electrical contact with the enclosure for grounding purposes. Refer to the text and illustrations in Section titled PC Component Grounding to ensure that good electrical contact is established when mounting the components. Figure 3.17 illustrates methods of mounting the Chassis and connecting the equipment grounding conductor.

**CAUTION:** Care must be taken not to allow the I/O Chassis to warp when mounted. This may occur if the back panel is slightly curved. Chassis distortion can cause stress on the printed circuit board of the Chassis backplane. This may result in the poor connection of the I/o modules and their backplane sockets.

---

To minimize warping, carefully inspect the spacing between the Chassis mounting brackets and the enclosure back panel with the mounting nuts hand-tightened. If spaces are uneven, insert flat washers, as needed, onto the mounting bolts or studs to even the spacing. When this is accomplished, wrench-tighten the mounting nuts.

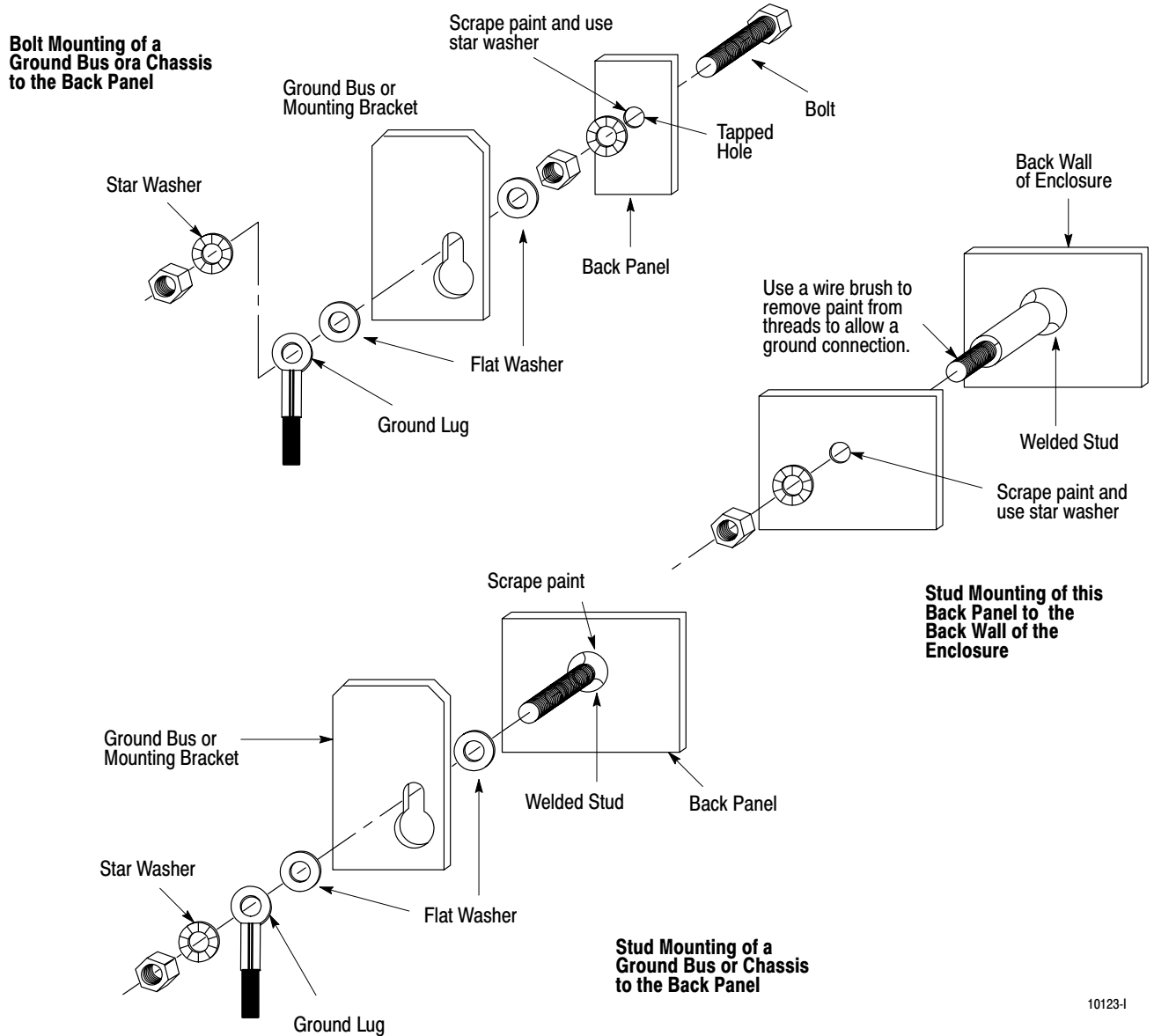
In addition to grounding considerations, component spacing and layout considerations must be observed. If the System Power Supply is to be mounted as a stand-alone unit, it cannot be mounted below the I/O Chassis.

The I/O Chassis and System Power Supply dimensions for both mounting configurations are shown in Figure 3.18 through Figure 3.20.

**I/O Chassis Assembly**

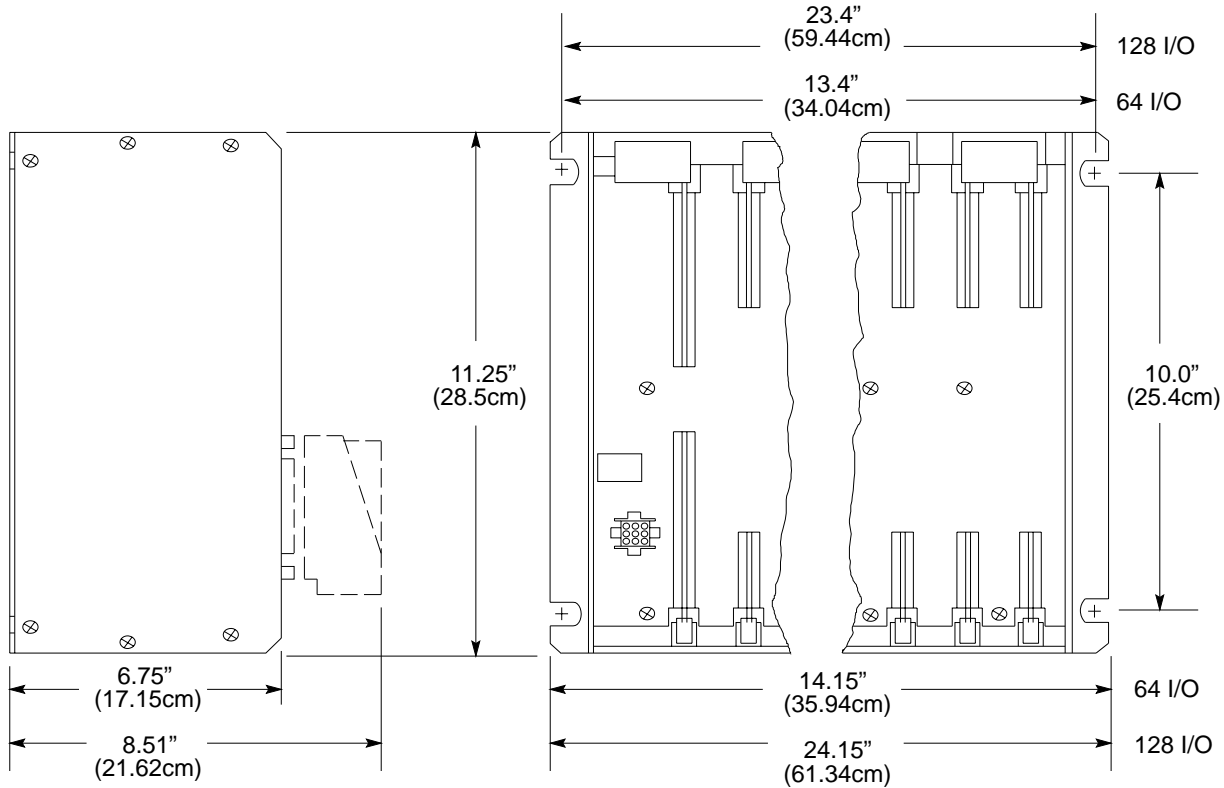
Once the Chassis and Power Supply are mounted, the remaining Controller parts can be installed in the I/O Chassis. This includes installing the I/O Power Cable, keying bands, EPROM, Processor, Field Wiring Arms and I/O Modules.

**Figure 3.17**  
**Mounting Assembly Details**



10123-1

**Figure 3.18**  
**I/O Chassis Dimensions**



10124-I

### I/O Power Cable

For ease of installation, the I/O Power Cable is installed prior to installing the Mini-PLC-2/15 Processor Module. The I/O Power Cable comes in two lengths to accommodate either Power Supply mounting configuration:

- 1 ft/30.5 cm (Cat. No. 1771-CL)
- 5 ft/1.5 m (Cat. No. 1771-CM)

The I/O Power Cable (Figure 3.21) has three plugs: one 3-pin plug and two 9-pin plugs that are labeled for proper connection. The 3-pin plug connects to the base of the Battery Pack. One 9-pin plug fits into the socket at the base of the Power Supply and the other 9-pin plug connects to the I/O Chassis socket. Side snap-lock levers hold the plug in the socket. To disconnect a cable, squeeze in on the snap-lock levers and pull gently.

### **EPROM Installation**

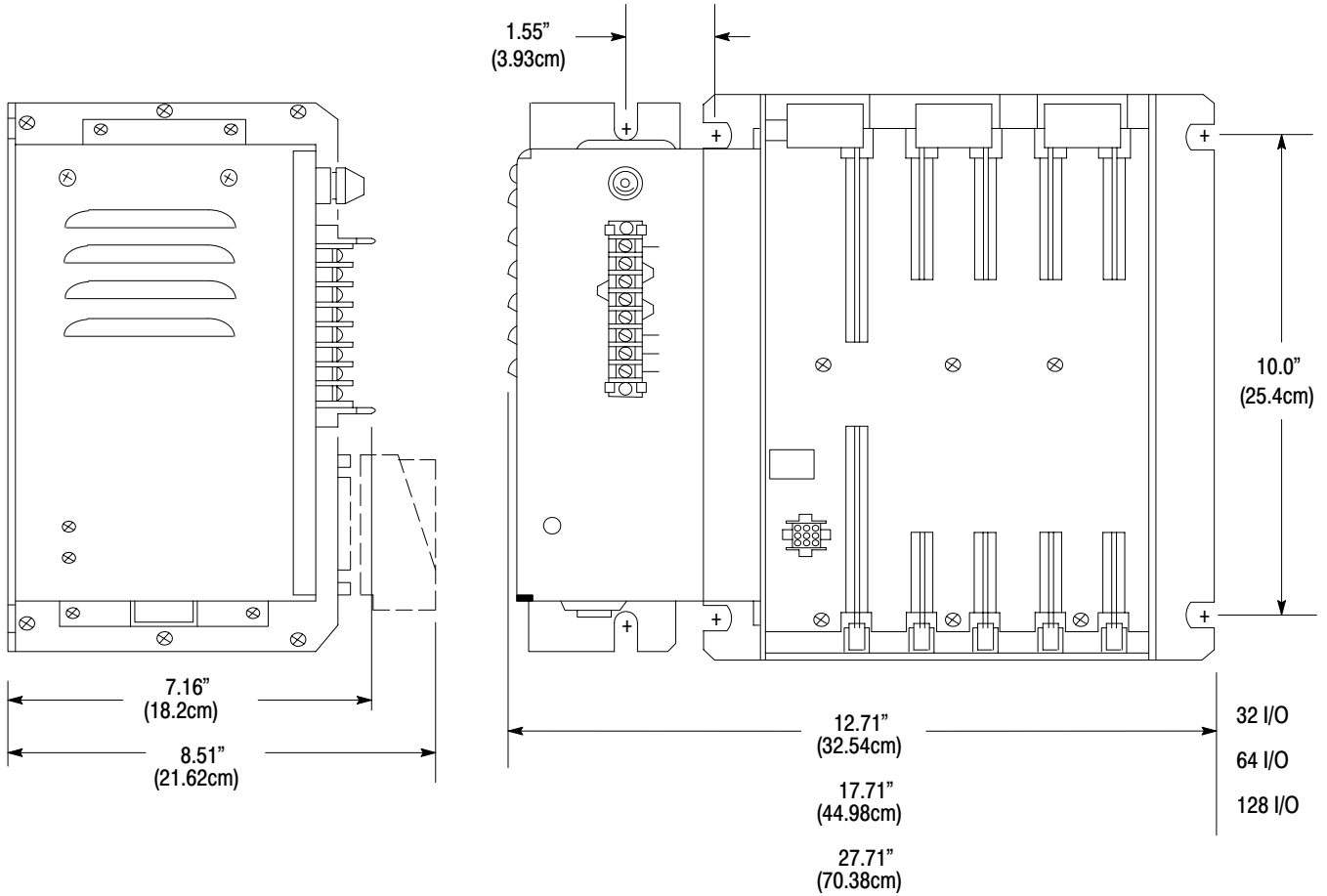
If the optional EPROM (Cat. No. 1770-XP) is to be used for non-volatile memory, it should be installed in the Mini-PLC-2/15 Processor before the Processor is installed in the I/O Chassis. Refer to the EPROM data sheet, Publication 1770- 915, for a complete description of the EPROM.

To install the EPROM, perform the following steps (Figure 3.22):

- 1.** Grip the EPROM at the edges and check all EPROM pins to ensure they are not bent or dirty.
- 2.** Loosen the screw and lift the EPROM access door on the side of the Processor.
- 3.** Push the ON tab to the left to unlock the 28-pin zero insertion force (ZIF) socket.
- 4.** Orient the EPROM so its notch faces the left side.



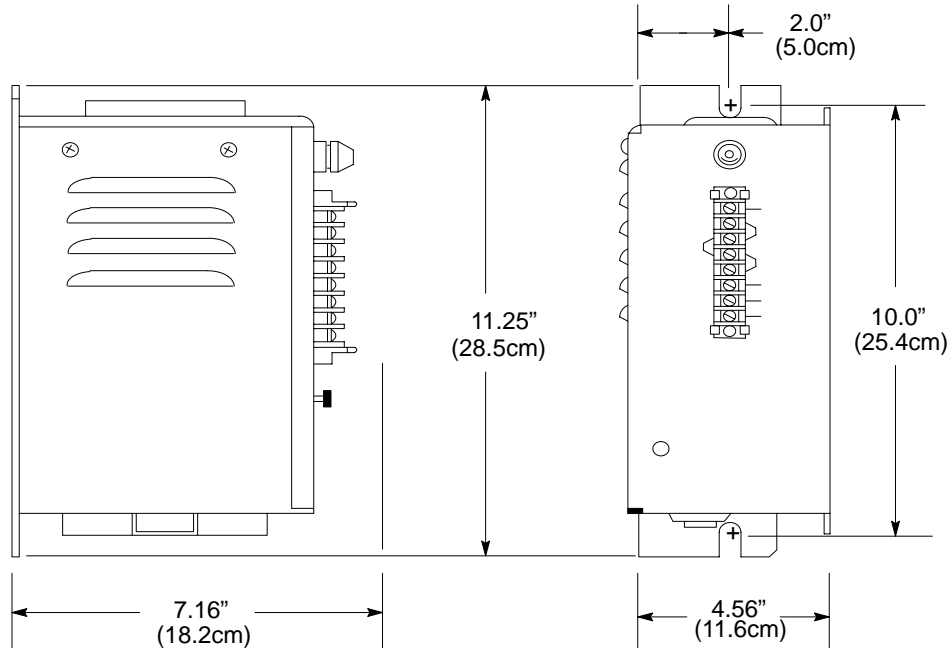
**Figure 3.19**  
**Power Supply and I/O Chassis Dimensions**



Note: For ease of assembly, Power Supply and I/O Chassis should be a unit before mounting.

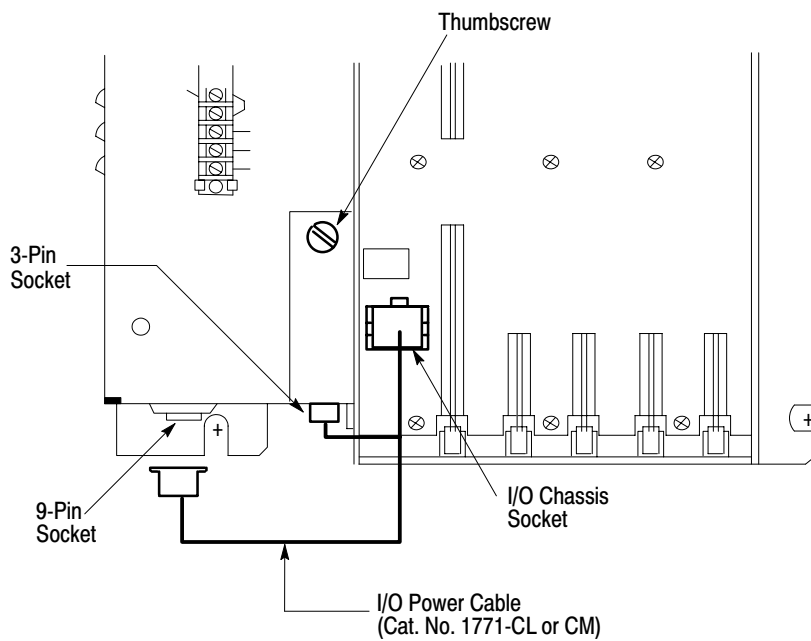
10125-1

**Figure 3.20**  
System Power Supply Dimensions



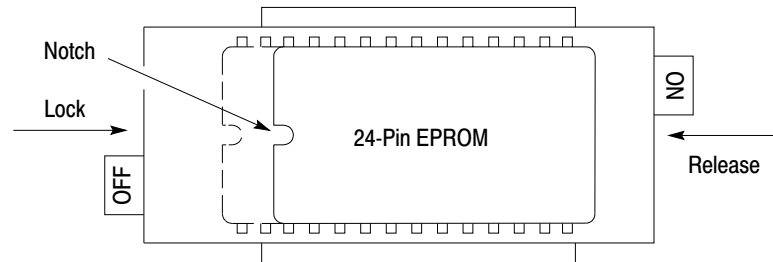
10126-I

**Figure 3.21**  
I/O Power Cable



10127-I

**Figure 3.22**  
**EPROM Installation**



10128-I

5. Line up the right side of the EPROM pin with the right side of the socket and seat the EPROM in the socket.
6. Lock the EPROM in place by pushing the OFF tab toward the right.
7. Close the EPROM access door and tighten the screw.

### Mini-PLC-2/15 Processor

The Mini PLC-2/15 Processor Module (Cat. No. 1771-LV) is inserted into the left-most slot of the I/O Chassis (Figure 3.23). With the Mode Select Switch in the PROG mode, slide the Processor Module onto the plastic tracks and push firmly to seat it in the backplane sockets. Once in position, snap down the Module Locking Latch to secure the Mini-PLC-2/15 Processor.

### Field Wiring Arms

Field Wiring Arms (Cat. No. 1771-WA) for each I/O Module slot are shipped with the I/O Chassis. If a different Field Wiring Arm is required for a certain Module, it is shipped with that Module.

The Field Wiring Arms snap onto the lower horizontal bar of the I/O Chassis (Figure 3.24). When I/O Modules are in place, the Field Wiring Arms pivot and connect to the Module.

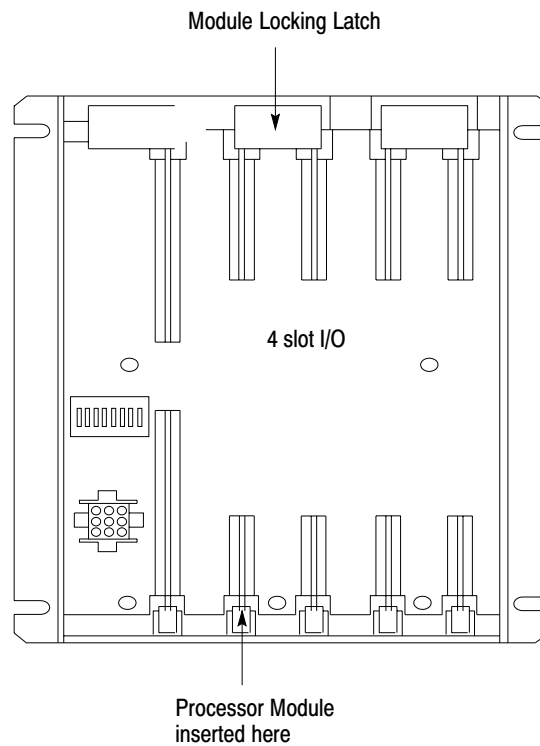
### I/O Modules

The I/O Modules are inserted into their corresponding keyed slots by sliding them onto the plastic tracks at the top and bottom of the slots (Figure 3.15). Do not force the I/O Modules into their backplane sockets; rather, apply firm and even pressure to seat them.

Note: If the I/O Module is a double-slot Module, it must occupy a complete Module Group. Overlapping of Module Groups is not permitted.

When a pair of I/O Modules (a Module group) is seated, the Module Locking Latch at the top of the I/O Chassis is snapped down to secure the I/O Module (Figure 3.15). The Field Wiring Arm is then pivoted up and snapped onto the wiring arm locking tab.

**Figure 3.23**  
Installing Processor Module



10841-1

## Wiring/Cabling Installation

Before actually running the signal wiring, refer to the wiring guidelines as outlined under “Field Wiring Considerations” and “Field Wiring Guidelines,” Section titled Field Wiring Considerations and Field Wiring Guidelines. Wiring installation will be discussed as it related to components.

**WARNING:** To avoid injury to personnel and damage to equipment, disconnect all AC and DC power to the Controller before attempting any wiring installation within the enclosure.

---

Each wire that connects to an I/O device, power source or common should be appropriately labeled. Tape, shrink-tubing, other dependable means of labeling can be used. The five-digit address is a convenient label for I/O wiring.

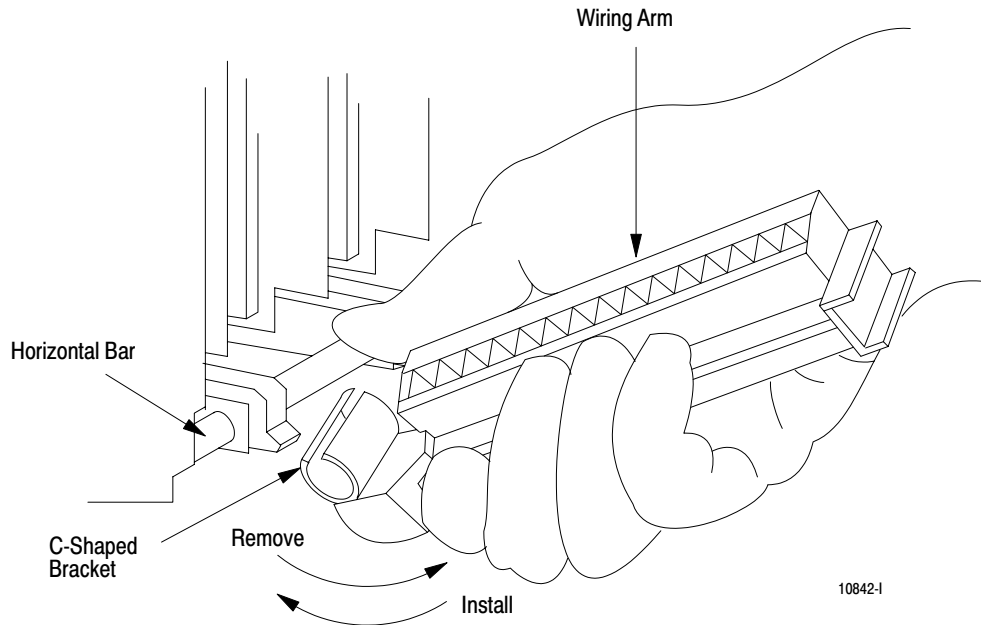
In addition to labeling, wire insulation color may also be used to distinguish the type of wiring signals. DC I/O signal wires may be blue in color and AC I/O signal wires may be red. Local electrical codes may specify insulation colors for various types of signals.

It is strongly recommended that the system installer document all I/O connections to the I/O Racks on a Connection Diagram Addressing Form (Publication 5039) (Figure 3.26). A copy of these completed forms should remain in the enclosure to serve as a wiring guide should troubleshooting the system become necessary.

The user may also want to identify the devices connected to the field wiring arm terminals and the status indicators on the I/O Module. Space is available next to the terminals and the indicators for labeling (Figure 3.27). The 5- digit terminal address or the name of the I/O device can be used for labeling.

Wiring for each I/O Module should be bundled together within the wiring ducts as outlined under “FIELD WIRING GUIDELINES.”

**Figure 3.24**  
**Attaching Filed Wiring Arms**

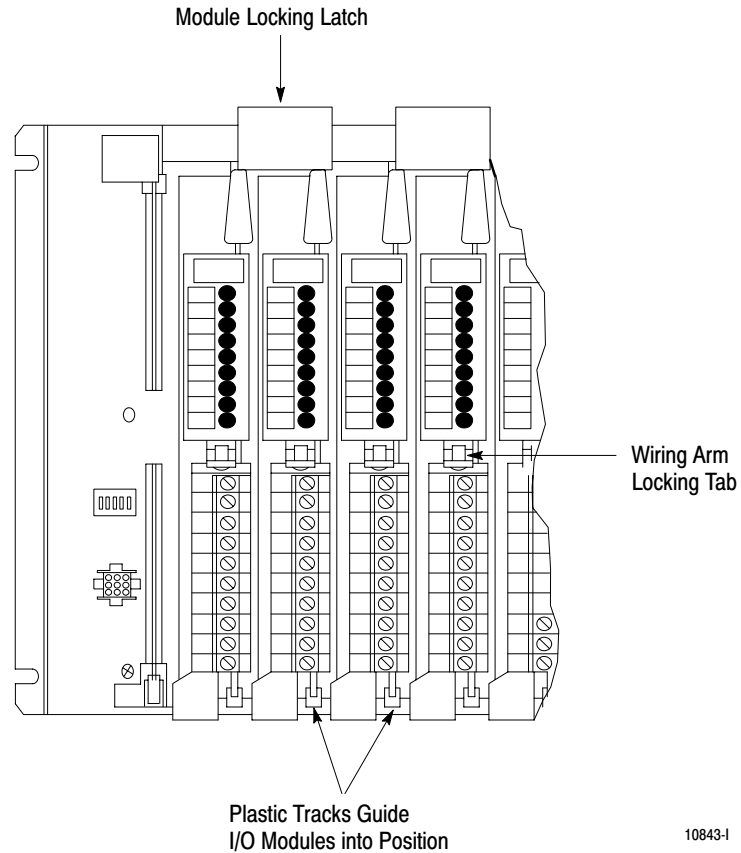


### **Field Wiring Considerations**

When planning duct layout, the following categories of wires and cables associated with an A-B Programmable Controller should be considered:

- I/O Power Cable carries regulated 5V to the Processor and the I/O Rack.
- Data Highway Cables (Serial Communication) carry data transmissions between Processors and/or Computers.
- Low Level DC I/O lines carry low voltage low per signals and their input circuits have short time constant filters so that short pulses can be detected. Low Level DC I/O lines connect TTL, Analog, Encoder/Counter, Pulse Output, Fast Response, Thermocouple and other Low Level DC I/O Modules.
- AC I/O lines and High Level DC I/O lines have a greater degree of noise immunity than Low Level DC I/O lines.

**Figure 3.25**  
I/O Module Insertion



### Field Wiring Guidelines

The following are general wiring guidelines for A-B Programmable Controller components. These guidelines are applicable to typical installations for user wiring inside and outside the enclosure:

- Use 14 AWG (stranded) wire or smaller as permitted by local codes to connect to the Field Wiring Arms.
- All AC I/O lines and High Level DC I/O lines can be routed with machine power lines of up to 600V AC (feeding up to 100 horsepower devices), if this does not violate local codes. Article 300-3 of the National Electric Code requires that all conductors (AC and/or DC) in the same duct must be insulated for the highest voltage carried by one of the conductors in the duct.

**Figure 3.26**  
1771 Input/Output Assignment Form



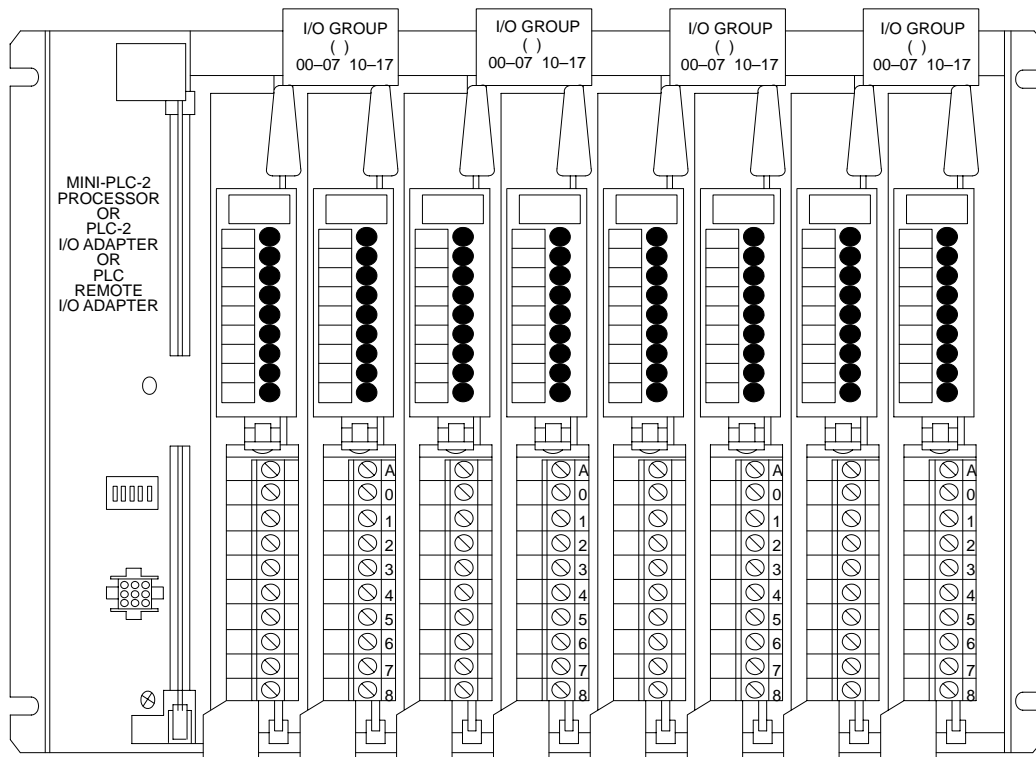
Bulletin 1771 I/O Chassis  
**CONNECTION DIAGRAM ADDRESSING**  
(Publication 5039 – September, 1980)

PAGE \_\_\_\_\_ OF \_\_\_\_\_

DATE \_\_\_\_\_

PROJECT NAME \_\_\_\_\_

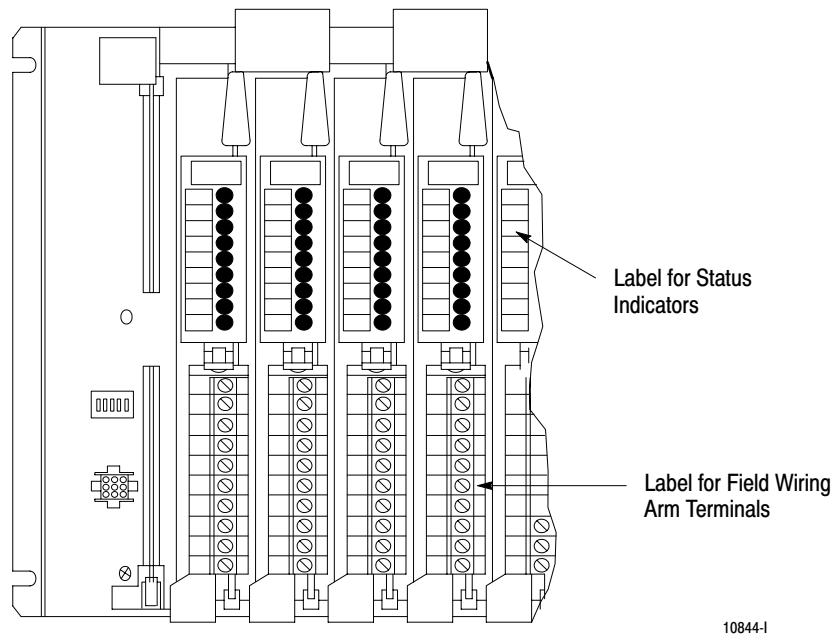
DESIGNER \_\_\_\_\_



10701



**Figure 3.27**  
Field Wiring Arm/Indicator Labeling



10844-1

- All Low Level DC I/O lines must be properly shielded and run in a separate duct. Serial Communication Cables may also be run with these lines.
- I/O Power Cable should remain external to all wiring ducts or in a duct not shared with other wiring within the enclosure.

### 1771 I/O Wiring Installation

**WARNING:** To avoid injury to personnel and damage to equipment, disconnect all AC and DC power to the Controller before attempting any wiring installation within the enclosure.

---

The specific wiring required for each type of I/o module is described in the Module's Product Data Sheet. General wiring procedures are described below.

Pivot the Field Wiring Arm up and snap it onto the wiring arm locking tab. Use a flat-head screwdriver to remove the terminal cover from the wiring arm to expose the terminals. Trim the wire to the appropriate length to reach the terminal. Strip approximately 3/8-inch of insulation from the end of the wire.

Bend the end of the wire to to the right and place the bare copper wire under the pressure plate of the terminal screw. (Optionally, a spade lug can be used.) Tighten the screw, and check that the wire is firmly in place. Bundle each Module's wires together and push them into the wiring duct. when completed, the bundled wires should look similar to those shown in Figure 3.28.

Low Level DC I/O lines require shielded cable for signal transmission and must be run in a separate wiring or in a duct containing only LOW LEVEL DC I/O lines and Serial Communications Cables. use Belden 8761 Cable or its equivalent. this cable has a single insulated twisted-pair with a foil shield covering its entire length and a bare drain wire (Figure 3.29). The twisted-pair consists of a signal wire and its signal return. The shield's function is to reduce the effect of induced noise at any point along the cable.

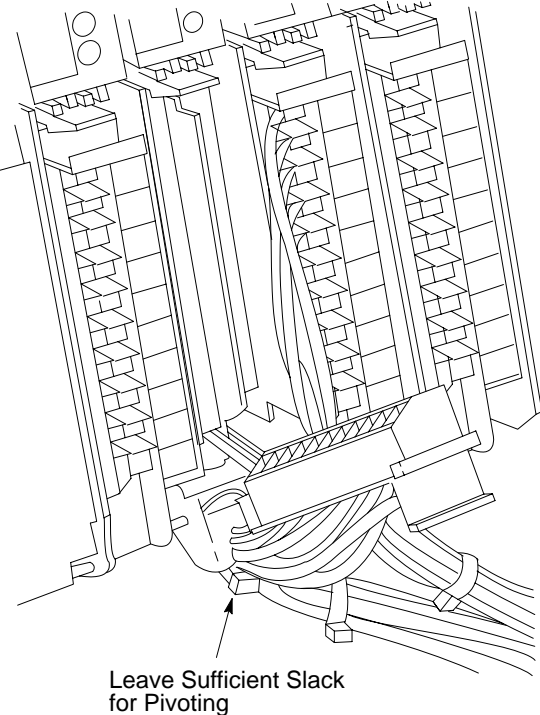
General procedures for connecting a shielded cable to a Field Wiring Arm are described below. Consult the Module's Product Data Sheet for specific wiring connections.

Strip approximately 3 ft of insulation from the Belden 8761 Cable at the Field Wiring arm end. Peel the shield away from the pair of insulated wires (Figure 3.29). Either strip off the shield foil at the insulation or twist it together with the bare drain wire thereby forming a single strand (Figure 3.30). it may be necessary to insulate the shield with tape or shrink tubing along areas where it might otherwise come into contact with wiring arm terminals.

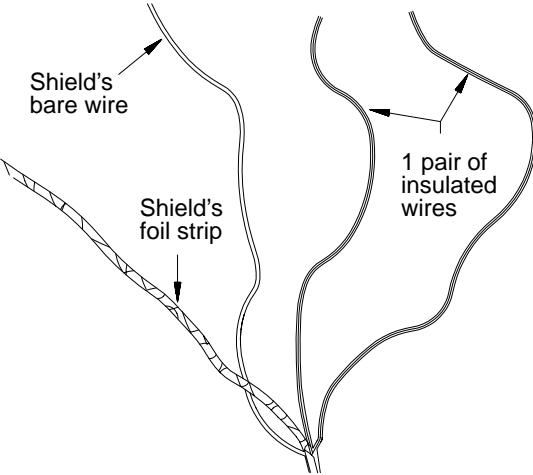
Trim both insulated wires to 2-inch lengths and strip approximately 3/8-inch of insulation from the end of each wire. The shield strand is left at its full 3- ft length (Figure 3.31). Then, connect the insulated wires to the Field Wiring Arm terminals.

The twisted shield strand must be properly grounded only at one end. The recommended grounding point for the shield is at the I/o Chassis. Connect the twisted shield strand to ground by placing it between the I/O Chassis mounting bracket and the flat washer before the nut is tightened. A lug can be used (Figure 3.32).

**Figure 3.28**  
**Field Wiring Arm**

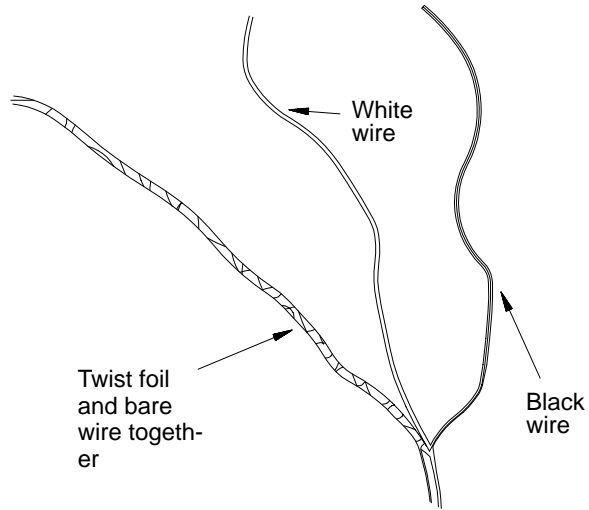


**Figure 3.29**  
**Peeling Foil Shield**



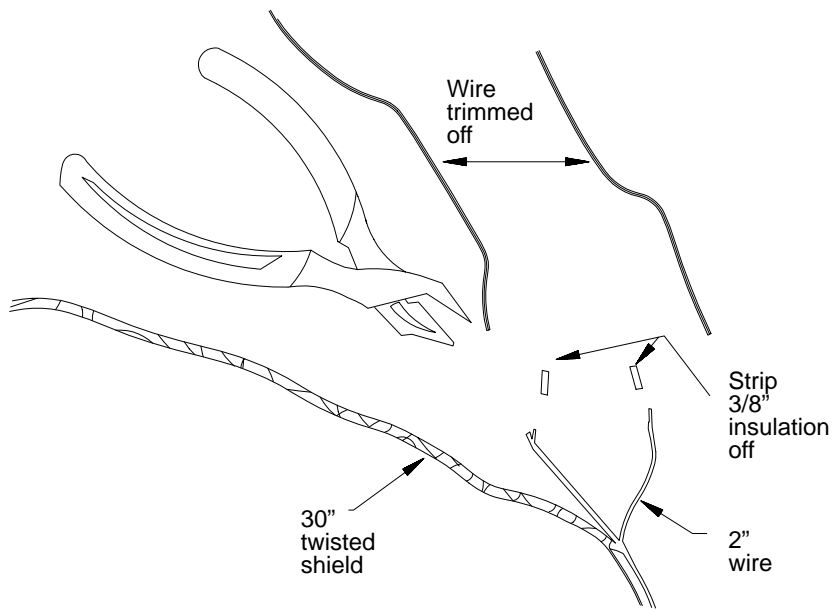
10707-1

**Figure 3.30**  
Twisting Foil Shield and Wiring



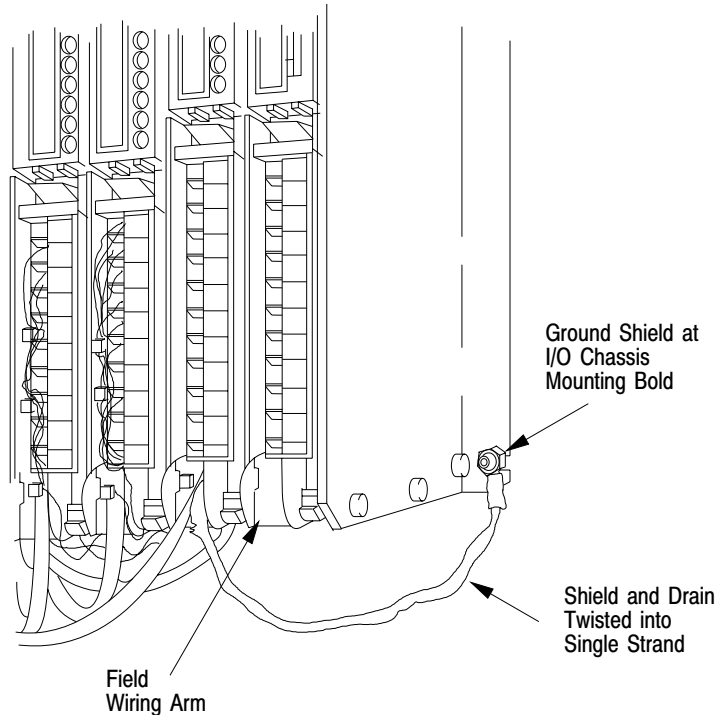
10708-1

**Figure 3.31**  
Trimming Unnecessary Insulated Wire



10709-1

**Figure 3.32**  
Cable Shield Connection



17798

The shield cable at the field devices can be configured as described in Figure 3.33.

### Incoming AC Wiring Guidelines

When bringing AC power into the enclosure, the raceway or conduit may be an equipment grounding conductor which should be connected to the ground bus on the back panel. Ground loops may introduce objectionable ground currents causing faulty operation of the Programmable Controller. If the use of multiple grounding connections results in faulty operation, refer to Article 250-21 of the National Electric Code. This Article recommends methods of reducing objectionable ground currents. Local Codes and Ordinances dictate which earth grounding method is permissible.

When AC power is supplied as a separately derived system through an isolation stepdown transformer, it can be connected as a grounded AC system or an ungrounded AC system. In a grounded AC system, one side of the transformer secondary must be connected to the ground bus (Figure 3-34).

In an ungrounded AC system, one side of the ground fault indicator test switch must be connected to the ground bus (Figure 3.35).

AB Drives

When the System Power Supply Chassis cannot be directly connected to the enclosure or the enclosure ground bus, an equipment grounding conductor must be connected to the terminal labeled “Equipment Ground” on the System Power Supply’s terminal strip.

### **Master Control Relay**

A hard-wired Master Control Relay, supplied by the user, provides emergency power shutdown for Controller I/O devices. Since the Master Control Relay allows for the placement of several Emergency Stop switches in different locations, its installation is strongly recommended. Typical Master Control Relay configurations are shown in Figure 3.34 and Figure 3.35.

When any Emergency Stop switch is operated, power to input and output devices is removed. Power is still supplied to the System Power Supply so that the Processor can continue to operate even though all of its inputs and outputs are “powered down”.

**NOTE:** The Master Control Relay is not a substitute for a disconnect to the Controller. It is intended for any situation where the operator must quickly de-energize I/o devices. When replacing any module, replacing output module fuses or working on equipment within the enclosure, power must be shut off to the Controller system.

**CAUTION:** It is the user’s responsibility to install the Master Control Relay and the Emergency Stop switches. The user must make certain that relay contacts have sufficient rating for the particular application. Emergency Stop switches must be located to provide quick and easy access to the operator or maintenance personnel. Emergency Stop switches must be wired in series.

---

**WARNING:** Emergency Stop switches can be monitored as inputs in the user program but must not be controlled by the PC. Any Emergency Stop switch must turn off all input and output devices by de-energizing the Master Control Relay.

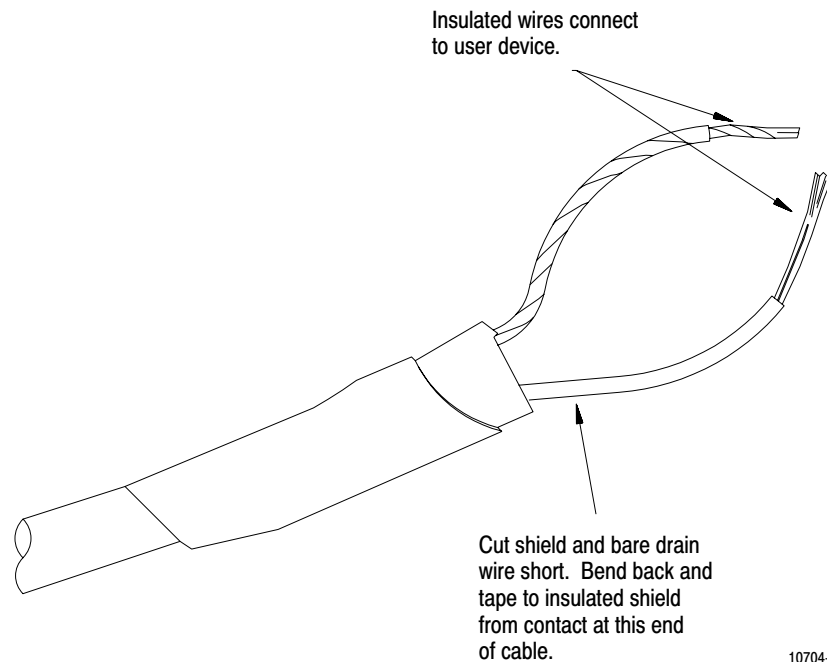
---

### **Input Power Connection to System Power Supply**

AC Line connection is made to the terminal strip located on the front of the System Power Supply (Figure 3.36). This System Power Supply is factory-shipped configured for 120V AC operation.

**WARNING:** To avoid injury to personnel and damage to equipment, disconnect all AC and DC power to the Controller before attempting any wiring installation within the enclosure.

**Figure 3.33**  
**Shielded Cable at User's Device**



The user must reposition the two metal jumpers on the terminal strip for 220/240V AC operation. Jumper positions for both 120V AC and 220/240V AC operation are shown at the terminal strip (Figure 3-36).

In addition to repositioning the jumpers for 220/240V AC operation, the main AC fuse of the System Power Supply must be changed. The Power Supply is shipped with a 1 amp slow-blow fuse installed to accommodate 120V AC operation. When the Power Supply is to operate on 220/24V AC, the 1 amp fuse must be removed and the 0.5 amp fuse, shipped separately with the Power Supply, must be installed.

AC input line connections are made to L1 and L2. (L2 is the high side of the AC line; L2 is the low side). No connection is made to the equipment ground terminal when the grounding configuration illustrated in Figure 3-7 is used. Also see the last paragraph under “Incoming AC Wiring Guidelines” (Section titled Incoming AC Wiring Guidelines).

**CAUTION:** The user must make certain that the System Power Supply is correctly jumpered for either 120V or 220/240V AC. Incorrect jumpering on the terminal strip may cause improper operation or damage to the Power Supply.

---



## Industrial Terminal Installation

The Bulletin 1770 Industrial Terminal System (Cat. No. 1770-T3) is used to program the Mini-PLC-2/15 Processor. The Industrial Terminals (Cat. No. 1770-- T1 or -T2) can be used, however they will limit the capabilities of the Mini- PLC-2/15 Processor.

**WARNING:** Do not use a 1770-T1 or 1770-T2 Industrial Terminal to edit or change a program or Data Table values that were generated using a 177-T3 Industrial Terminal. Block instructions and instructions with word addresses 4008 or greater will not be displayed properly. The ERR message may appear randomly in the User Program at instructions and addresses that the 1770-T1 and 1770-T2 Industrial Terminals are not designed to handle. Changes to the User Program and/or Data Table with a 1770-T1 or 1770-T2 Industrial Terminal could result in unpredictable machine motion with possible damage to equipment and/or injury to personnel.

---

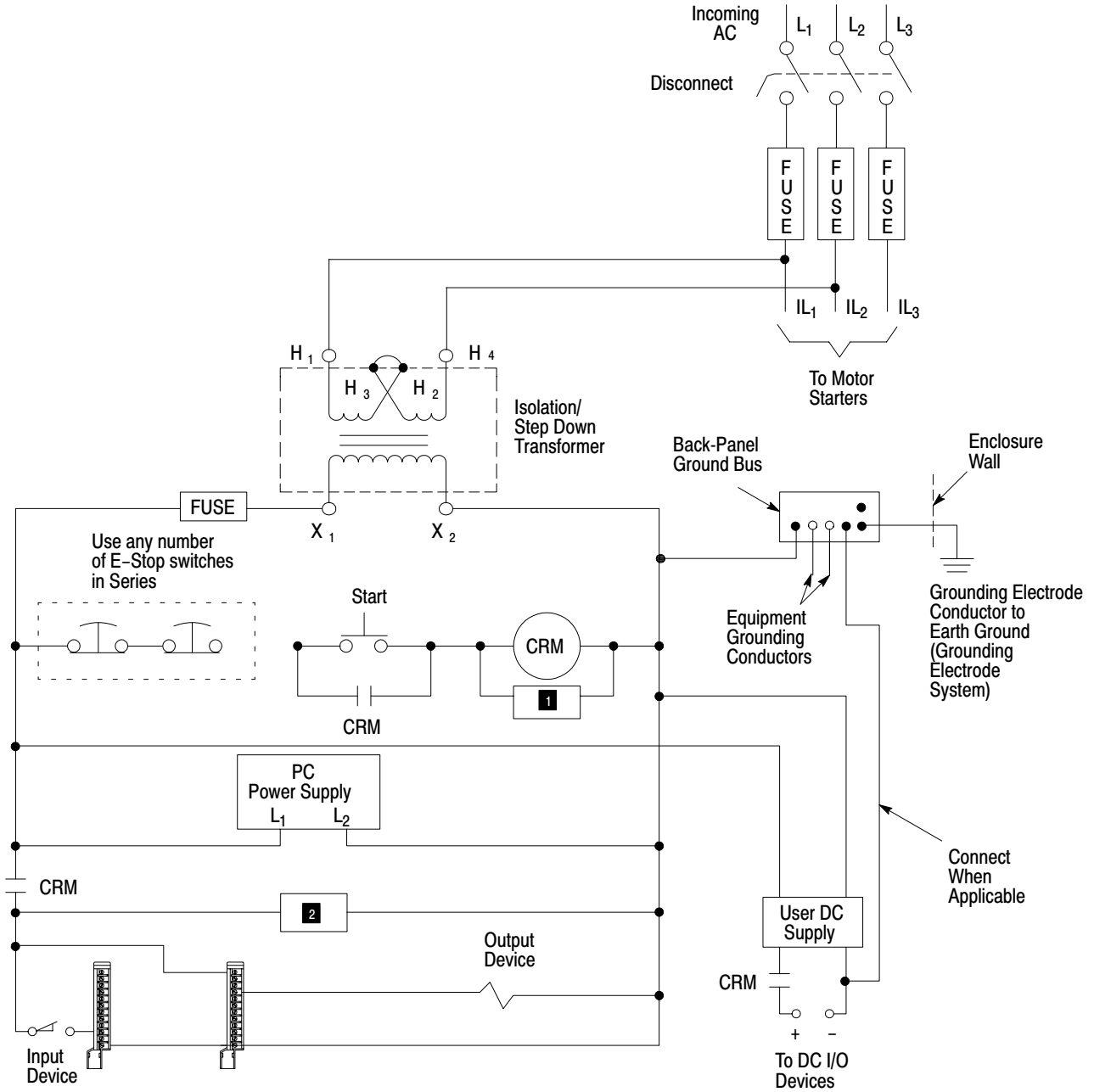
All necessary cables for connecting the Industrial Terminal to the Mini-PLC-2/15 Processor are shipped standard with the Industrial Terminal System. For ease of cable connections, sockets and connectors are configured to mate only in the proper way. Cable connections between the Processor and the Industrial Terminal can be made with power applied to both the Processor and Industrial Terminal.

A grounding type AC line cord for 120V AC operation is standard with the Industrial Terminal. An AC line cord for 220/240V AC operation must be constructed. This line cord must only be plugged into a grounded AC outlet to minimize exposure to electrical hazard.

The Industrial Terminal is factory-shipped configured for 120V AC operation. If the Industrial Terminal is to operate on line voltages of 220/240V AC, refer to the Industrial Terminal System User's Manual (Publication 1770-805), for changing the AC setting and AC fuse, and for general operating procedures.

The Industrial Terminal System (Cat. No. 1770-T3) is connected to the Mini-PLC-2/15 Processor with the Program Panel Interconnect Cable (Cat. No. 172-TC). One end of this cable is connected to the socket labeled Channel A at the back of the Industrial Terminal and the other end is connected to the INTERFACE socket on the front of the Processor (Figure 3.37).

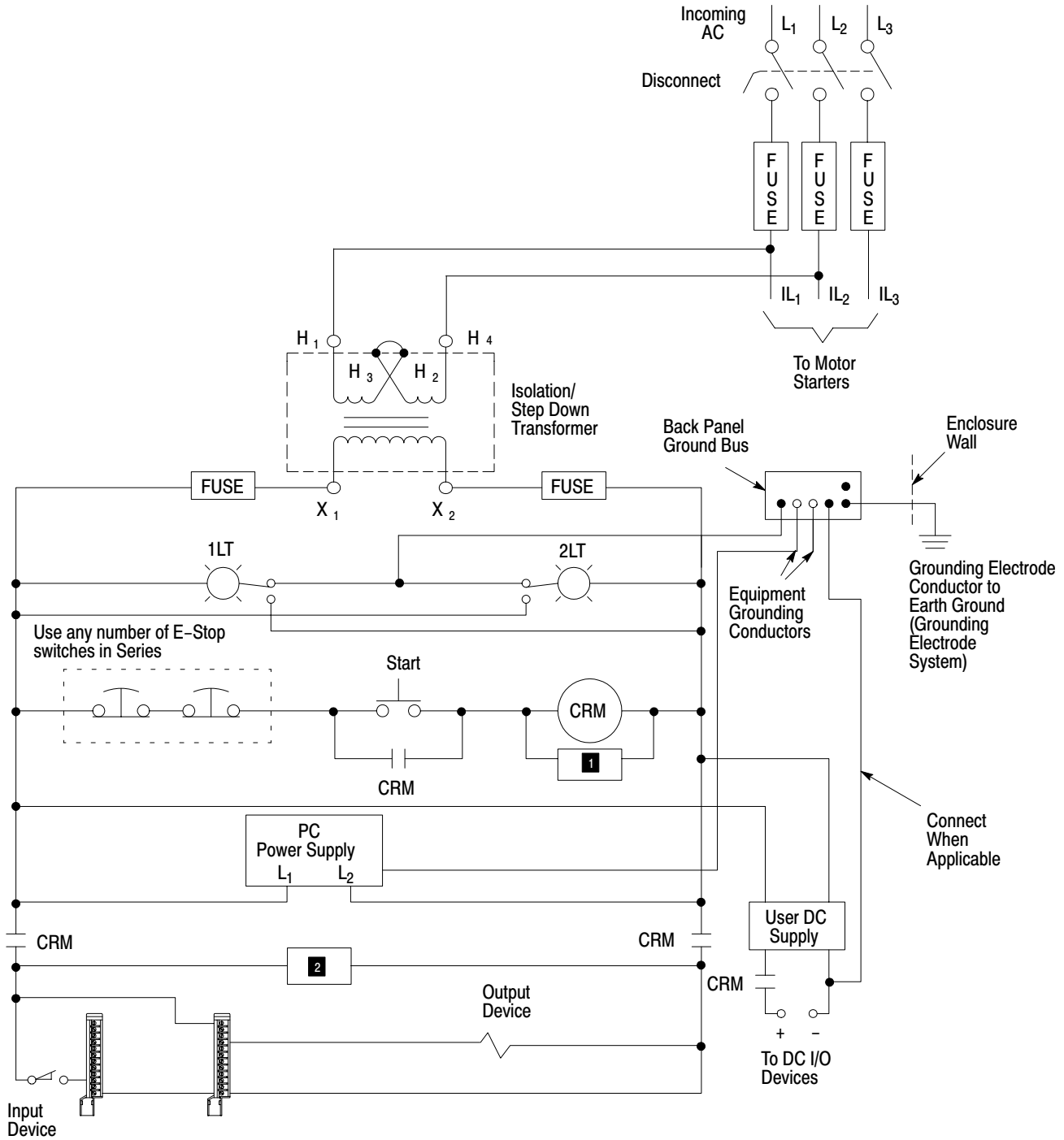
**Figure 3.34**  
**Power Distribution with Master Control Relay, Grounded System**



**1** To minimize EMI generation, connecting a suppression network is recommended: for 120V AC, Allen-Bradley cat. no. 1691-N2; for 220/240V AC, Electrocube part no. RG 1676-13.

**2** To minimize generation, connecting a suppression network is recommended: for 120V AC, Electrocube part no. RG 1676-14; for 220/240V AC, Electrocube part no. 1676-28.

**Figure 3.35**  
**Power Distribution with Master Control Relay, Ungrounded System**

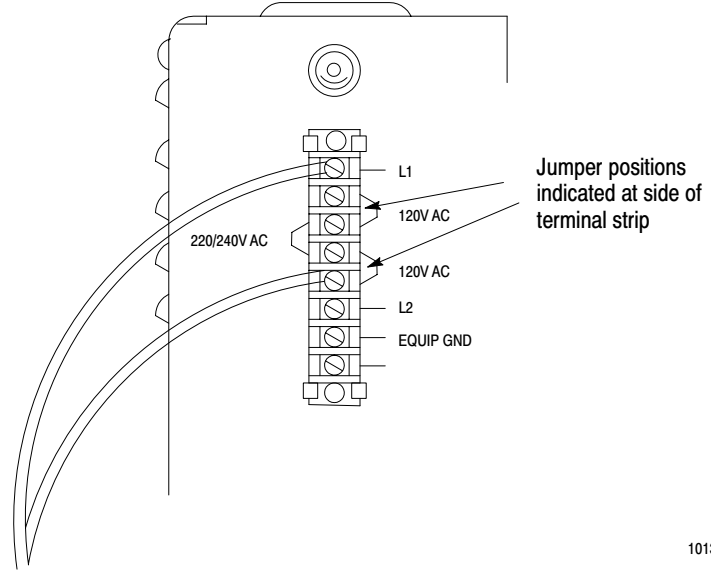


**1** To minimize EMI generation, connecting a suppression network is recommended: for 120V AC, Allen-Bradley cat. no. 1691-N2; for 220/240V AC, Electrocube part no. RG 1676-13.

**2** To minimize EMI generation, connecting a suppression network is recommended: for 120V AC, Electrocube part no. RG 1676-14; for 220/240V AC, Electrocube part no. 1676-28.

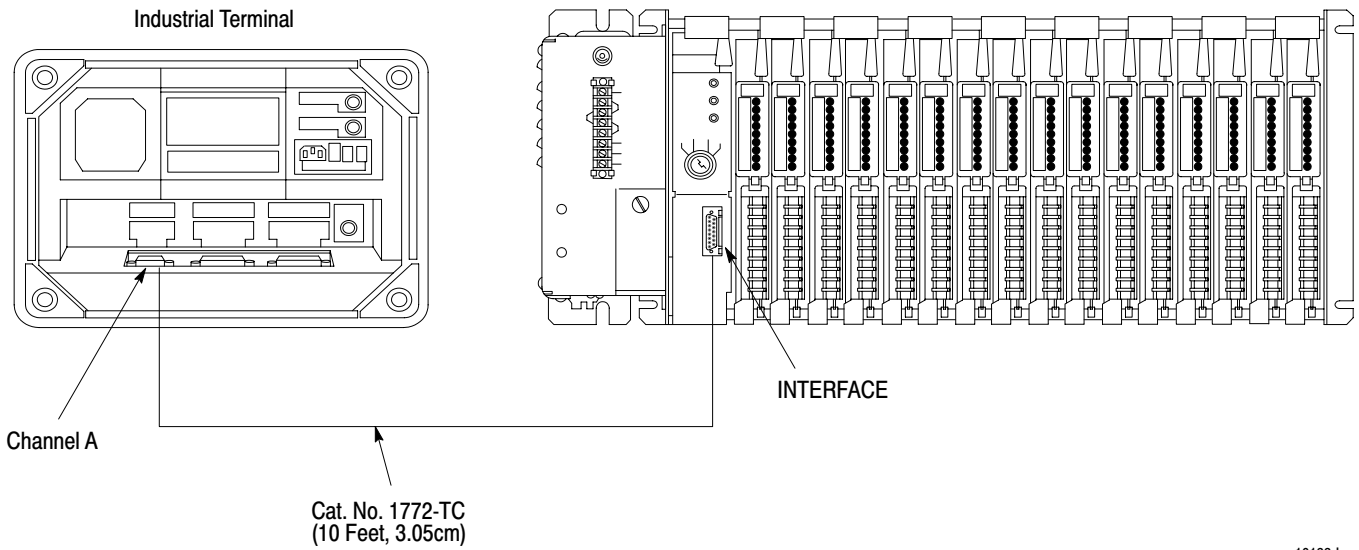


**Figure 3.36**  
**External Power Terminal Strip**



10132-1

**Figure 3.37**  
**Industrial Terminal Connection**



10133-1

## System Start-Up

### Start-Up

Careful start-up procedures are essential for proper Mini-PLC-215 Controller operation. These procedures should be followed after the complete Controller system has been assembled and installed as described in Section 3.

A cautious approach must be taken toward the initial start-up procedure. Care and patience during start-up will isolate problems that might occur in the form of programming errors, wiring mistakes, or equipment malfunction. The procedures outlined will help the user to uncover problems under controlled conditions. This will not only make it easier to pinpoint problems but will also minimize possible equipment damage or personal injury.

In general, checkout procedures are performed in three stages:

- Without power applied to the Controller components
- With power applied to all devices except those that allow machine motion
- with power applied to all devices which are controlled by the User Program.

### Checkout Before Applying Power

**WARNING:** Machine motion during system checkout can cause injury to personnel or damage to equipment. During the first stage of checking out the system, disconnect any device that might cause machine motion to occur when energized.

---

The following steps must be performed before AC power is applied to the Controller:

1. Verify that the jumper-selected voltage settings on the System Power Supply and Industrial Terminal match the incoming AC line voltage. Also verify that the AC line voltage is within tolerance. For 120V AC operation, the normal range is 98–132V AC; for 220/240V AC operation, the normal range is 196– 250V AC.
2. Verify that the proper fuse is in the fuseholder: 1A for 120V AC, 0.5A for 220/240V AC.
3. Verify that the wiring of the main disconnect and Master Control Relay is correctly installed.

4. Verify that the I/O Power Cable connectors are plugged securely into their sockets.
5. Verify that all modules are securely held in the I/O Chassis. Verify that the Field Wiring Arms are fully seated on their I/O Modules and locked in place on the locking tables.
6. Disconnect all motors from their starters, valves from their solenoids, etc., to ensure that no power-driven machine motion occurs when power is first applied to the Controller. Where this is not practical, disconnect the user wiring at some point other than the Field Wiring Arm terminal.

### **Checkout With Power Applied To Selected Devices**

**WARNING:** Machine motion during this procedure can cause injury to personnel or damage to equipment. Disconnect any device that might cause machine motion to occur when energized.

---

Before beginning, verify operation of the Master Control Relay and Emergency Stop Switches.

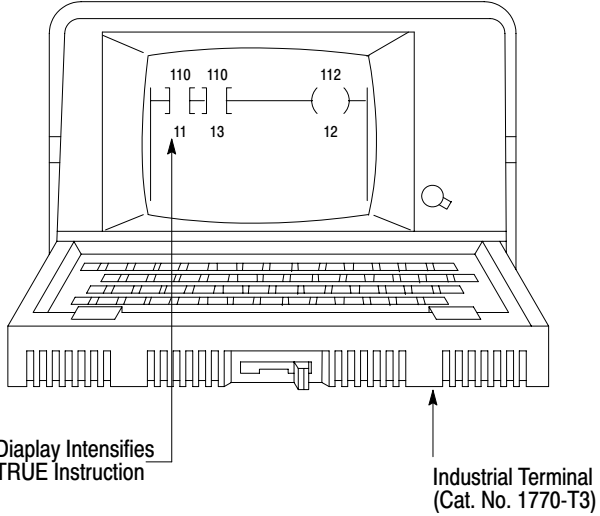
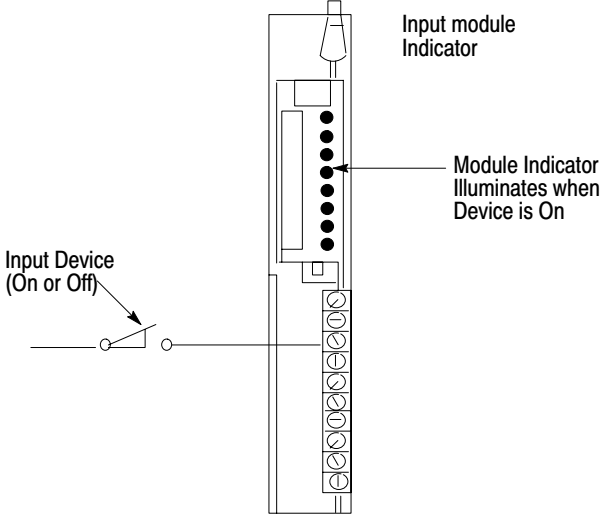
The next stage is to check out the system with power applied to all devices, except those that cause machine motion.

#### **Status Indicators/Industrial Terminal Use**

The system is checked out by comparing the actual I/O device status to the I/O Module indicators and the Industrial Terminal display (Figure 4-1). When a connected input device is ON, the corresponding indicator on the Input Module illuminates. When an output device is turned ON, the corresponding indicator on the Output Module illuminates. The output device need not be connected to the output terminal for the I/O Module indicator to illuminate. This is useful for checking out an output terminal that will be connected to a device causing machine motion.

The Industrial Terminal indicates the logical TRUE/FALSE status of an instruction. When an instruction is logically TRUE, the condition is specified is met and the instruction will intensify on the Industrial Terminal screen.

**Figure 4.1**  
**I/O and Industrial Terminal Status Indicators**



10134-I

10134-I

**Hardware/Indicator Comparison Procedures**

**WARNING:** Machine motion during this procedure can cause injury to personnel or damage to equipment. Disconnect any device that might cause machine motion to occur when energized.

The user must make certain that a program has not been entered into the Mini-PLC-2/15 Processor's memory. Only one rung at a time should be in memory for the start-up procedures. To clear the Processor's memory, connect the Industrial Terminal to the Mini-PLC-2/15 Processor and perform the following steps. Read and understand the Industrial Terminal System User's Manual, Publication 1770-805 before proceeding.

1. Install the keyboard and the PLC-2 Family Keytop Overlay on the 1770-T3 Industrial Terminal. Connect the Industrial Terminal to the Processor.
2. Turn the Mode Select Switch on the Processor to the PROG position.
3. Apply proper AC power to the Controller's Power Supply.
4. Turn the Industrial terminal power switch ON.
5. After the MODE SELECTION message is displayed on the screen, press [1][1] on the keyboard.
6. Press [SEARCH] [^] on the keyboard.
7. Regardless of what is displayed, press [CLEAR MEMORY][9][9] on the keyboard.

A "CLEARING MEMORY" message will be displayed on the third line from the bottom while memory is being cleared. The END statement will appear on the screen when memory has been cleared.

NOTE: Power is to be connected to the System Power Supply and most I/O devices. Do not apply power to any device causing machine motion.



**TESTING INPUTS**

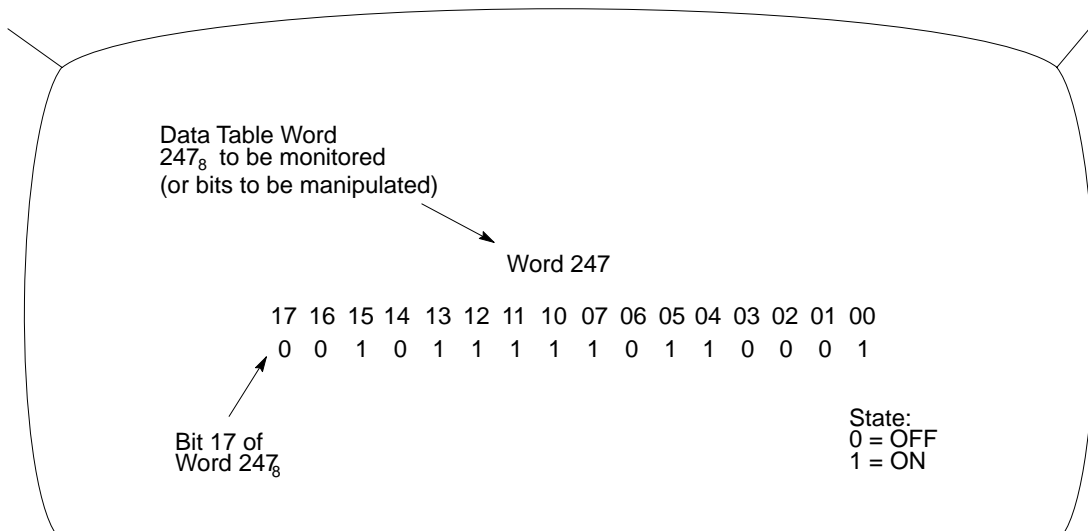
Hardware/indicator comparison should begin with the testing of input devices and modules. Perform the following steps for each input device:

1. Turn the Processor's Mode Select Switch to the TEST position.
2. Press [SEARCH][5][3] and enter the word address of the Input Module to be tested. The state of each input in the selected Module Group will be displayed in the format shown in Figure 4-2.

**WARNING:** Never reach into a machine to actuate a switch since unexpected machine motion can occur and cause injury to personnel. Do not use a metal rod since this could result in an electrical shock if it touches an exposed terminal. Instead, use a wooden stick or other non-conductive device to activate the switch.

3. For each input terminal, manually turn the corresponding input device ON and OFF. Observe the display and the corresponding Input Module indicator to verify the correct state is indicated.

**Figure 4.2**  
**Bit Manipulation Display**



10135-I

If the Input Module indicator does not turn ON when its corresponding device is CLOSED, either the device or its wiring is faulty. If the Input Module indicator turns ON, but this is not indicated at the Industrial Terminal, the Input Module is most likely malfunctioning. First try reseating the Input Module in the I/O chassis. If it still malfunctions, replace the Module as described in Section 5.6.2.

**CAUTION:** If an I/O Module is to be replaced, System power and I/O power must be removed. Failure to remove power could result in damage to the Module and/or unexpected machine motion.

---

Perform steps 2 and 3 until all inputs have been tested.

#### TESTING OUTPUTS

After all inputs have been tested, the outputs should be checked next. Some output devices are disconnected and must remain disconnected during this checkout procedure.

**WARNING:** Machine motion during this procedure can cause injury to personnel or damage to equipment. Disconnect any device that might cause machine motion to occur when energized.

---

Perform the following steps to the outputs:

1. Turn the Processor's Mode Select Switch to the RUN/PROG position.
2. Press [SEARCH][5][3] for bit manipulation.
3. Enter the word address of the Output Module to be tested. The state of each output in the selected Module Group will be displayed.
4. Use the [->] and [<-] keys to cursor over to the output to be tested. Press [1] to turn the output ON. Press [0] to turn the output OFF. Observe the corresponding Output Module indicator and the output device to verify the proper output action occurs. If the Output Module indicator operates correctly but the output device does not, either the output device or its wiring is faulty. If neither operates correctly, the Output Module is most likely at fault. First try reseating the Output Module in the I/O chassis. If it still malfunctions, replace the Module as described in Section 5.6.2.

**CAUTION:** If an I/O Module is to be replaced, System power and I/O power must be removed. Failure to remove power could result in damage to the Module and/or unexpected machine motion.

---

5. Perform steps 3 and 4 for all outputs except those that cause machine motion.

## **Checkout of Machine Motion**

At this point, the Controller, the connections and mot of the user's hardware will have been tested. The final procedure is to check out the machine motion or process controlled by the actual User Program.

The basic approach initiates testing with the least amount of machine motion. Only some outputs are allowed to generate machine motion. Thus additional machine motion can be added gradually, thereby allowing any problems to be detected more easily under more controlled conditions.

Before continuing, review the User Program. After this is completed, the final system checkout can begin. The Programming and Operations Manual, publication 1772-804 contains programming information and Processor use with the 1770-T3 Industrial Terminal.

### **Final System Checkout**

**WARNING:** When machine motion is generated, an alert competent person must be ready to operate an Emergency Stop switch, which will de-energize the Master Control Relay. This removes all power from the machine.

---

Perform the final system checkout as follows:

1. Turn the Processor's Mode Select Switch to the PROG position. Press [SEARCH] [↑] to display the first rung in memory. Press [CLEAR MEMORY][9][9] to clear the entire Mini-PLC-2/15 Processor memory. when the memory has been cleared, the END statement will be displayed.
2. Enter the User Program into memory. Check the program instructions to ensure they have been entered correctly.
3. Support Processor memory with battery backup. Remove System and I/o power.
4. Make a list of output devices that can be independently tested without causing danger to personnel or the machine. This list would include such items as coolant pumps, fans, and indicators.
5. Chose one or a group of output devices from the list and reconnect them for full operation.
6. Restore System and I/o power.
7. Turn the Mode Select Switch to RUN or RUN/PROG. Actuate the required inputs to operate one of the chosen output devices.

**WARNING:** Never reach into a machine to actuate a switch because unexpected machine motion could occur and cause injury to personnel. Do not use a metal rod since this could result in an electrical shock if it touches and exposed terminal. Instead, use a wooden stick or other nonconductive device to activate the switch.

---

If the output device fails to operate, check to see if the Output Module indicator is ON for the corresponding output terminal. If the indicator is ON, the output device or its wiring is faulty. If the indicator is OFF, the program may be incorrect.

8. Repeat steps 5, 6 and 7 until all outputs from the list are tested.

**CAUTION:** As additional devices are enabled, be alert to improper mechanical interaction between output devices. For example, a program may erroneously be causing motors or clutches for both forward and reverse motion to be ON at the same time. Remove power immediately if this situation occurs.

---

9. Plan the safest possible order in which the remaining output devices can be reconnected for full operation. These are the ones not listed in Step 4. These will be the more difficult output devices to check out than those that cannot be independently tested. The machine motion should be enabled as gradually as possible thereby allowing any problems to be detected as early as possible under the most controlled conditions practical. After each group of output devices is selected, repeat Steps 6 and 7. As these output devices are reconnected for full operation, a record of progress should be kept so that no confusion will exist as to what has been actually checked out.

### **User Program Storage**

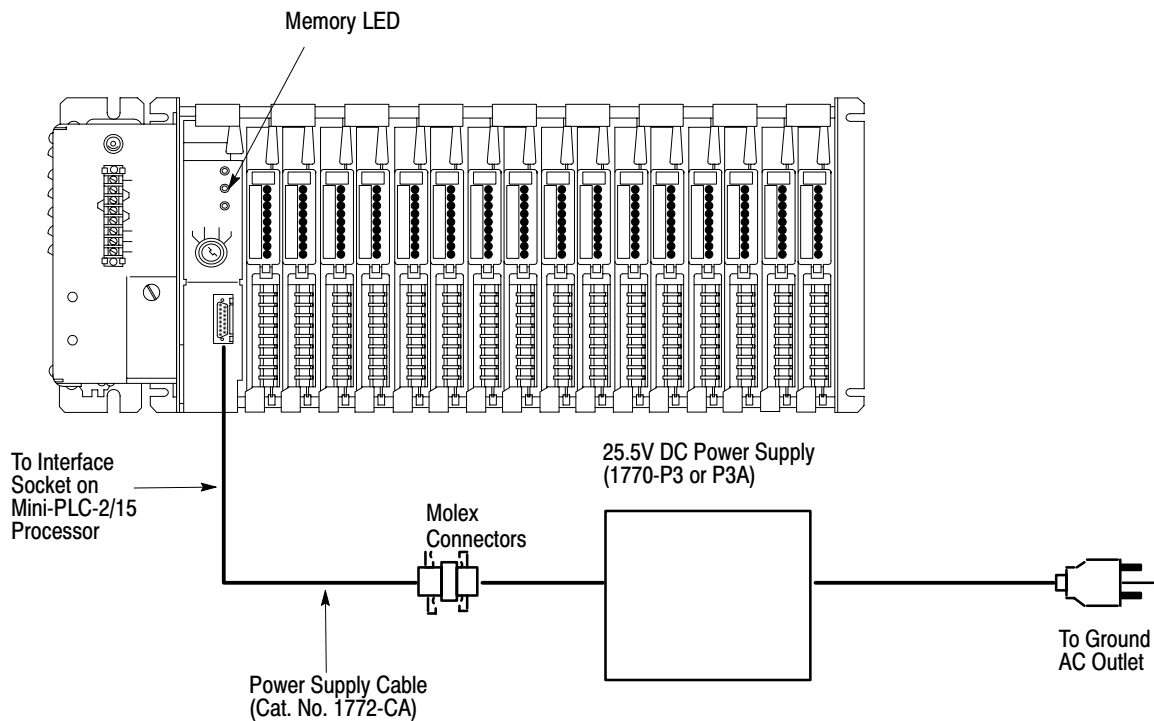
After the entire system has been checked out, it is recommended that a copy of the program be made with the optional Digital Cassette Recorder (Cat. No. 1770-SA) or the Data Cartridge Recorder (Cat. No. 1770-SB). Refer to their User's Manuals for recording the program on magnetic tape. A ladder diagram dump or total memory dump will also be useful for documenting the program.

The user may also want to use an EPROM (Cat. No. 1770-XP) for a non-volatile memory backup system. The EPROM is programmed while installed in the Processor using the Power Supply Assembly (Cat. No. 1772-PA or -PAA). During the programming process, the Processor's RAM memory is duplicated and transferred to the EPROM.

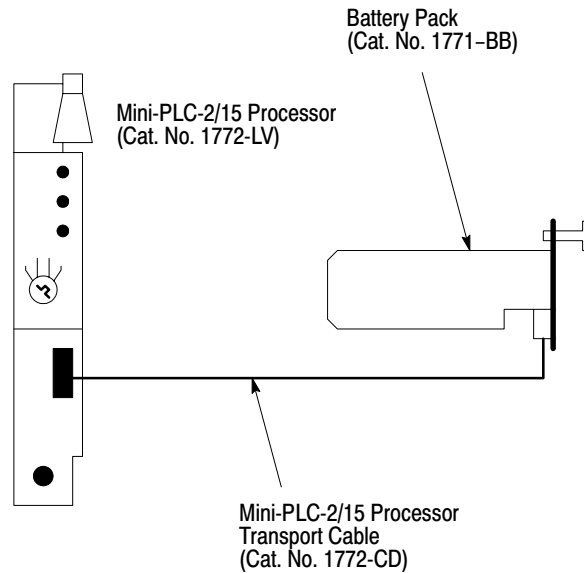
If an EPROM needs to be installed, perform the following steps to program an EPROM and refer to Figure 4-3:

1. Turn the Processor's Mode Select Switch to the PROG position and connect an external battery pack to support RAM memory as shown in Figure 4-4.
2. Remove AC power from the system.
3. Remove the Processor from the I/O Chassis. Grip a blank EPROM at its edges and check all pins to ensure they are clean and straight. Install the blank EPROM in the Processor as described in Section 3.5.2. Reinstall the Processor in the I/O Chassis and restore AC power.
4. Connect one end of the Power Supply Cable (Cat. No. 1772-CA) to the Power Supply (Cat. No. 1770-P3 or -P3A). Connect the Power Supply's AC power cord to a grounded AC outlet (Figure 4-3).

**Figure 4.3**  
**EPROM Programming Setup**



**Figure 4.4**  
External Battery Backup



10137-I

5. Connect the other end of the Power Supply Cable to the INTERFACE socket on the Processor. As soon as this connection is made, EPROM programming will begin.

During EPROM programming, the Memory LED on the Mini-PLC-2/15 Processor will blink ON and OFF. When EPROM programming is successfully completed, the Memory LED will turn OFF. If the Memory LED stays ON after programming, either the EPROM is faulty or an error has occurred during EPROM programming. To correct the memory fault, remove the EPROM and either erase the EPROM with a UV light source and reinstall it or install another blank EPROM in the Processor.

For more information on EPROM programming and the Power Supply Assembly, refer to their Product Data Sheets.

## Maintenance and Troubleshooting

### General

The Mini-PLC-2/15 Controller has been designed to minimize the need for maintenance and troubleshooting. Status and diagnostic indicators on the Controller help to trace the source of a fault to the user's hardware or the Controller.

### Preventive Maintenance

The Mini-PLC-2/15 Controller is an electrical system comprised of printed circuit boards. Every effort has been made to enclose this circuitry to limit its exposure to soot, oil spray, conductive particles, etc.

Dirty industrial environments require some special user considerations. The interior of the enclosure should be kept clean and the enclosure door should be kept closed, when possible, to exclude industrial contaminants.

Periodic inspection of terminal strip connections, plugs, sockets, and module connections for tightness should be made. loose connections may not only result in improper function of the Controller, but may also result in damage to the components of the system.

**WARNING:** To ensure personal safety and to guard against damaging the equipment, all connections should be inspected with external power removed from the system.

---

### Spare Parts

Stocking a full set of spare parts as replacement parts is recommended for minimizing downtime. Table 5.A, lists the spare parts and their recommended quantities for the Mini-PLC-2/15 Controller.

### Troubleshooting

Assuming proper grounding and wiring practices have been observed and system start-up procedures have been completed, most problems will have been identified and corrected. Those that have not can be identified and corrected by using a careful and systematic approach when troubleshooting. The step-by-step procedures presented in the

troubleshooting flowchart in Figure 5.1 will help the troubleshooter to identify the source of a fault systematically.

Generally, the sources of problems can be grouped into two board areas:

- User's hardware
- Programmable Controller

The most likely source of a problem is the user's hardware. This includes the wiring, I/O devices, I/O power source and system power. Programmable Controller faults can originate from the System Power Supply, Mini-PLC-2/15 Processor or the I/O Rack. Using the flowchart, and observing I/O device behavior and Controller indicators, the user should be able to trace the source of the problem to the user's hardware or the Controller.

The following sections will deal with troubleshooting problems as they relate to PC components. Observe all cautions and warnings as described in these sections. One general warning should be observed throughout the troubleshooting procedures:

**WARNING:** When cycling or removing line power, always use the main disconnect switch. Never use the AC line fuse to cycle or remove line power as contact with AC potentials may cause injury to personnel.

---

In addition to the flowchart, the troubleshooting chart (Table 5.B) provides a quick summary of corrective procedures according to Controller indicator status.

## **System Power Supply**

The System Power Supply converts the incoming AC voltage to the proper DC voltages to power the Processor and I/O Modules. The DC ON indicator illuminates when the output voltages of the Power Supply are correct. If the DC ON does not illuminate when AC power is applied, the possible fault sources could be:

- A blown Power Supply fuse
- Incorrect position of jumpers on the terminal strip
- Incorrect line voltage at Power Supply
- Power Supply load of 6.5 amps is exceeded
- Malfunctioning Power Supply

If the DC ON indicator illuminates but the RUN indicator is OFF when the Controller is in the RUN or RUN/PROG mode, possible fault sources can include:

- AC line voltage out of range
- Incorrect output voltages from Power Supply
- Malfunctioning I/O Power Cable
- Malfunctioning Processor



**Table 5.A**  
**Recommended Spare Parts**

Quantity	Cat. No.	Description
		<b>POWER SUPPLY</b>
1	1770-XO	Lithium Battery
		or
2	1771-BA	D-size Alkaline Battery
1	1771-BB	Battery Pack (includes 2 alkaline batteries)
1	1771-CL	I/O Power Cable (1 ft./30.5 cm)
1	1771-CM	I/O Power Cable (5 ft./1.5 m)
1	1771-FP	Fuse Package for Power Supply; includes 5 1A slow-blow fuses for 120V use 5 0.5A slow-blow fuses for 220/240V use
1	1771-P1	System Power Supply
		<b>PROCESSOR</b>
2	1770-XP	EPROM memory, 2048 word capacity
1	1772-CD	Mini-PLC-2/15 Processor Transport Cable (1 ft./30.5 cm)
1	1772-LV	Mini-PLC-2/15 Processor
1	1772-TC	Program Panel Interconnect Cable (10ft./3.05 m)
		<b>I/O</b>
1 or 10%	1771-	1771 I/O Modules
1	1771-FC	Fuse Package for 1771 I/O Modules (five 2A, 120V Fuses)

### Power Supply Fuse Replacement

If the AC line fuse has blown, the cause of the blown fuse must be corrected and the fuse must be replaced. Follow these steps to replace a blown Power Supply fuse:

**WARNING:** Contact with AC line voltages may cause injury to personnel. Always remove system power at the main disconnect before replacing the Power Supply fuse.

1. Remove AC power from the System Power Supply using the main disconnect.
2. Remove the fuse cap by pushing in slightly and turning counterclockwise. The fuse cap and the fuse holder will pop out of the fuseholder.
3. Install the replacement fuse (1 amp for 120V AC; 0.5 amp for 220/240V AC) in the cap and insert into the fuse holder. Push in and turn the fuse cap clockwise to seat in the fuseholder.
4. Restore system power.

### **Power Supply and I/O Power Cable Voltage Measurements**

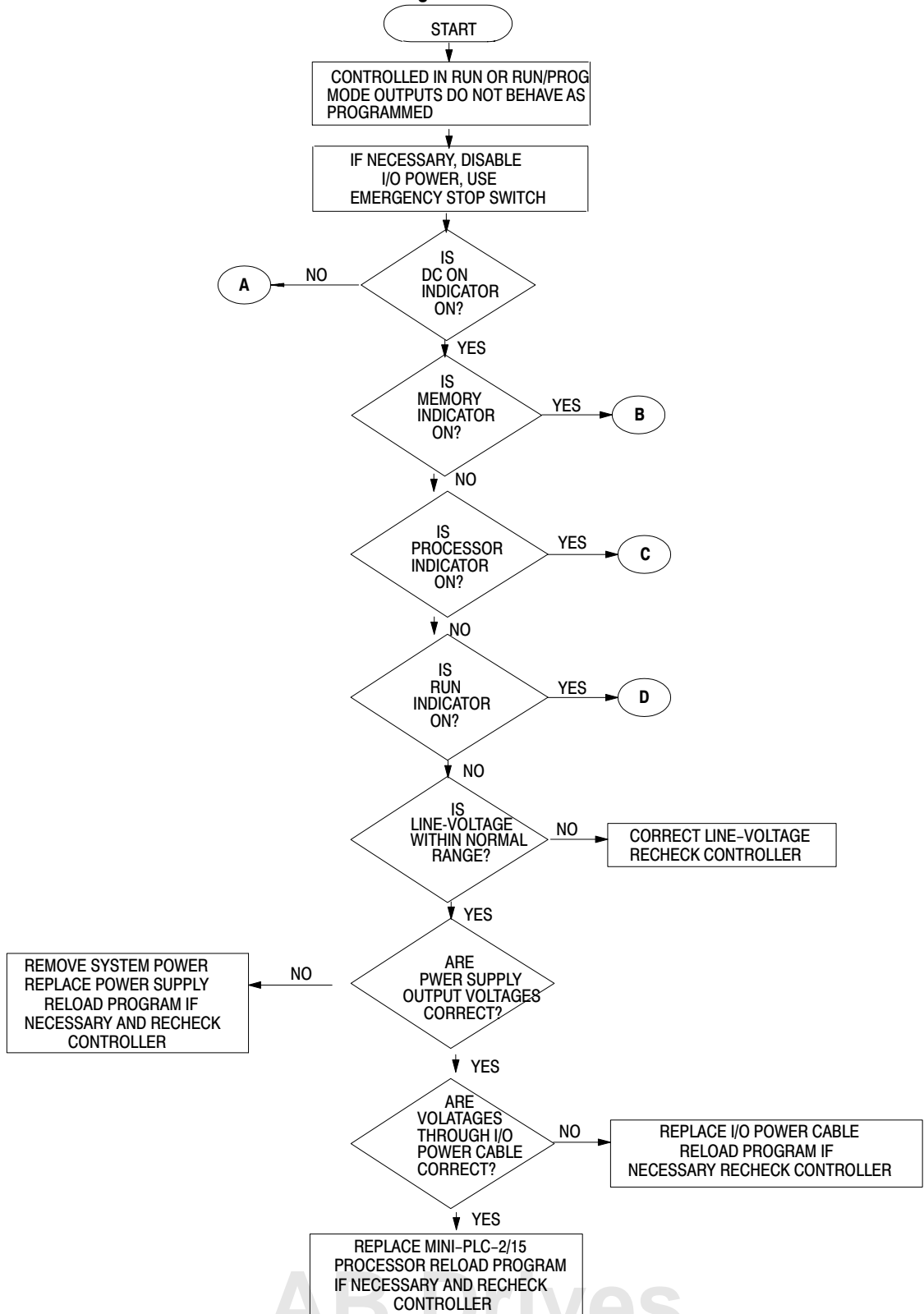
Output voltage measurements can be made at the base of Power Supply and at the end of the I/O Power Cable where it connects to the I/O Chassis backplane to determine whether power is getting to the backplane. Although measurements do not provide a complete diagnosis of the Power Supply, they can identify problems during troubleshooting. A voltmeter, accurate to  $\pm 1\%$ , can be used for these measurements.

The pins at the Power Supply socket and the end of the I/O Power Cable are numbered 1 through 9 as shown in Figure 5.2. The voltages for the pins are also listed. Note that pins 6 and 9 cannot be measured directly with a voltmeter.

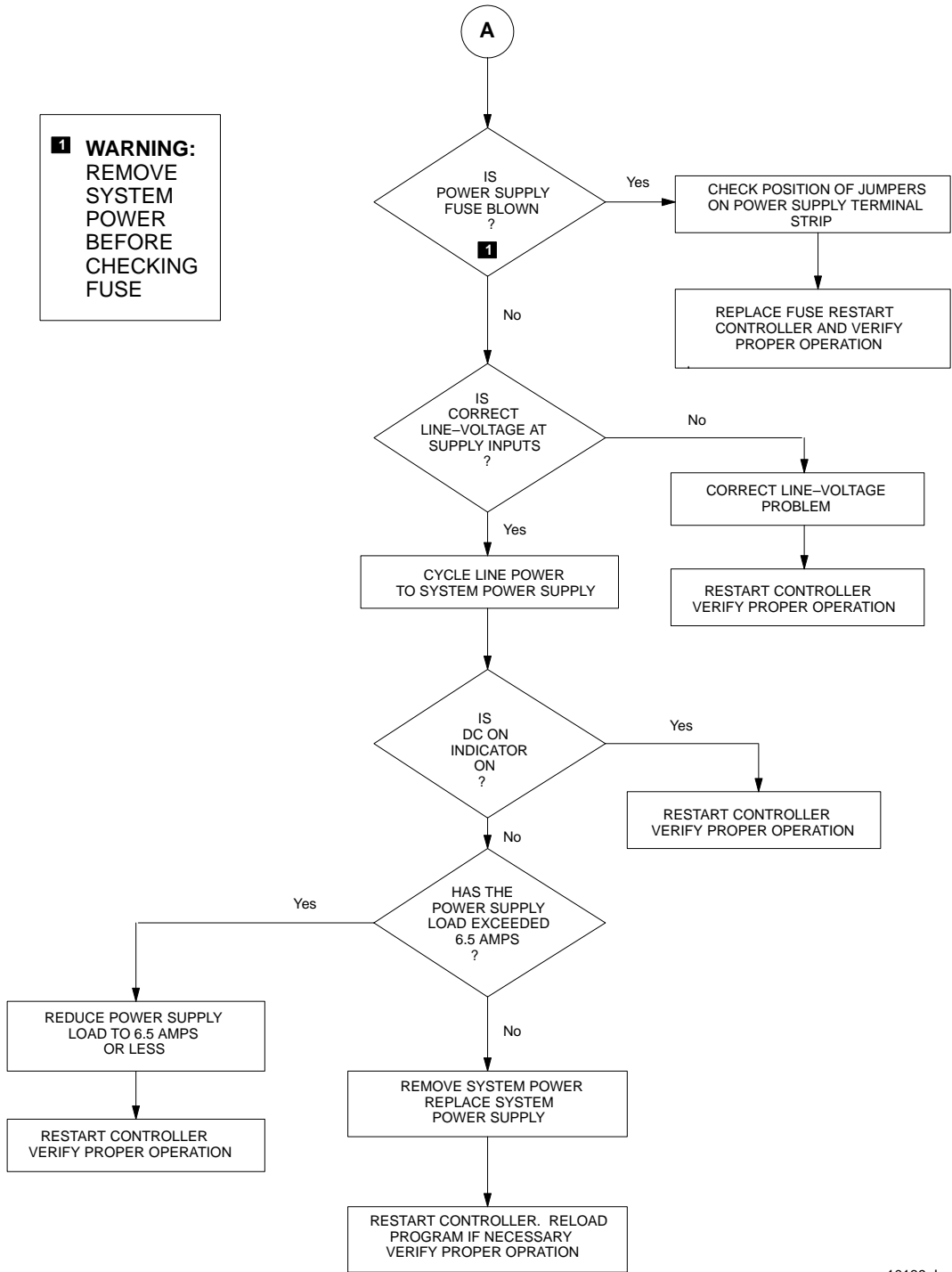
Follow these steps to measure the voltage at the Power Supply socket:

1. Turn the Processor's Mode Select Switch to the PROG mode. To support Processor memory, be sure there is battery backup or a programmed EPROM in place. If not, be sure there is a copy of the program on magnetic tape for convenient reloading.

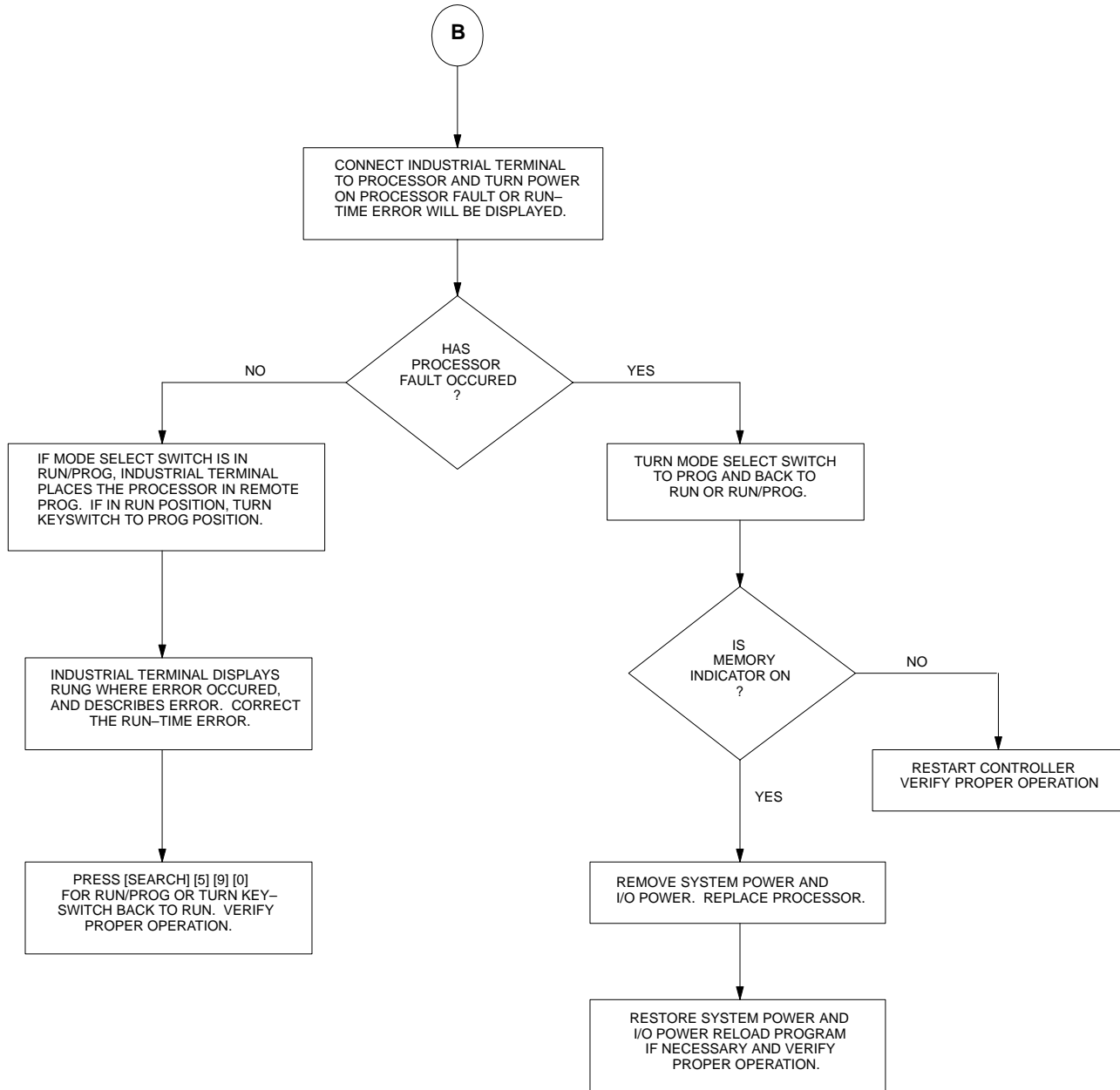
**Figure 5.1**  
**Troubleshooting Flowchart**



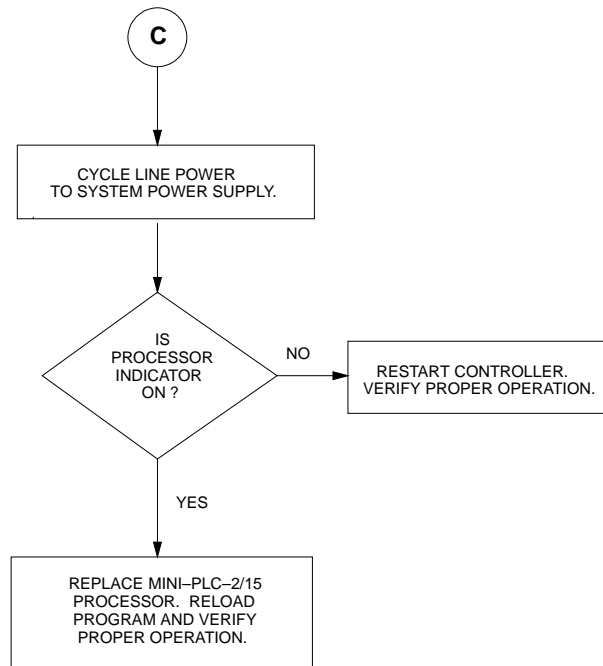
**1 WARNING:**  
REMOVE  
SYSTEM  
POWER  
BEFORE  
CHECKING  
FUSE



10139-I



10140-I



10141-I

2. Remove AC power from the Power Supply using the main disconnect.
3. Remove the I/O Power Cable from the Power Supply socket. To do this, squeeze in on the side levers of the cable.
4. Restore AC power to the Power Supply and measure the voltages at the Power Supply socket. If the voltages at the pins are less than specified in Figure 5.2, remove system power and replace the Power Supply.

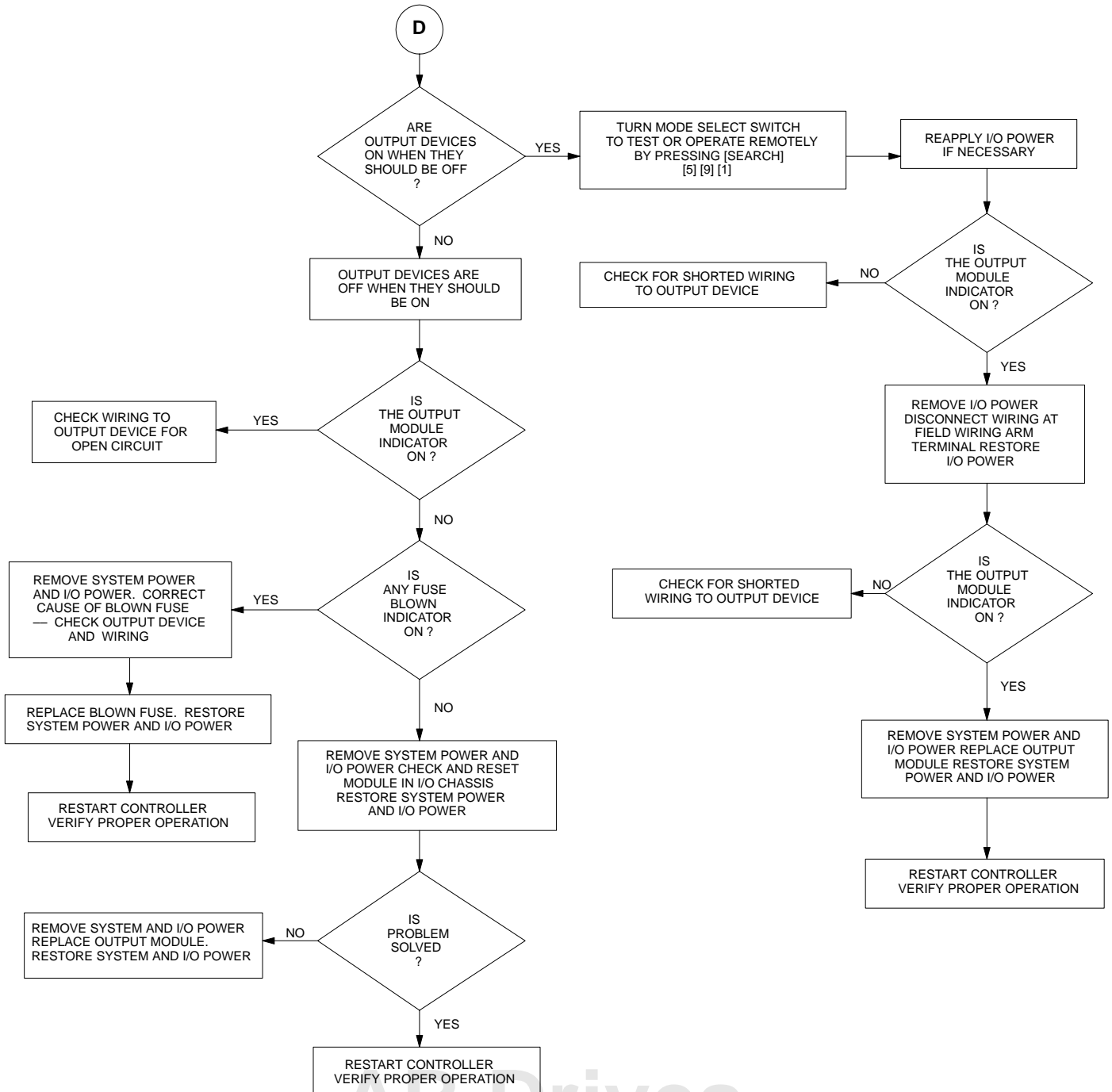
Follow these steps to measure the voltages at the end of the I/O Power Cable that connects to the I/O Chassis.

1. Turn the Processor's Mode Select Switch to the PROG mode. Support Processor memory with an external battery pack (Figure 4-4) or with a programmed EPROM in place. If not, be sure there is a copy of the program on magnetic tape for convenient reloading.
2. Remove AC power from the Power Supply using the main disconnect.
3. Remove the Processor from the I/O Chassis.
4. Disconnect the I/O Power Cable from the I/O Chassis backplane.
5. Restore system power to the Power Supply.
6. Measure the voltages at the end of the I/O Power Cable. If the voltages are incorrect, remove system power and replace the I/O Power Cable.

**System Power Supply Replacement**

The System Power Supply should be replaced if it is unable to provide the correct output voltages to power the Processor and I/O Modules. perform the following steps to replace the Power Supply:

1. Turn the Processor's Mode Select Switch to the PROG mode and support Processor memory.

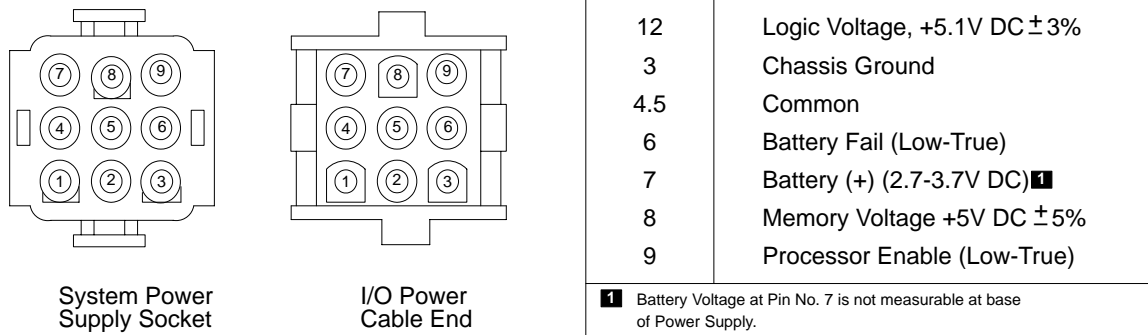


**Table 5.B**  
**Troubleshooting Chart**

Controller	Troubleshooting Indicators				
Mode[1]	Processor	Memory	Run	DC ON	Procedures to Correct Fault
T, R, or R/P	ON	OFF	OFF	ON	1. Cycle line power. 2. Replace Processor
	OFF	OFF	OFF	OFF	1. Check Power Supply fuse. 2. Check AC line voltage. 3. Cycle line power. 4. Verify Power supply load does not exceed 6.5A 5. Replace System Power Supply
T or R	ON	ON	OFF	ON	1. Connect Industrial Terminal to Processor and turn Mode Select Switch to PROG. 2. If a run-time error occurred, correct it. 3. If a Processor fault occurred, turn keyswitch back to TEST or RUN. 4. Replace Processor
R or R/P	OFF	OFF	OFF	ON	1. Check AC line voltage. 2. Measure Power Supply output voltages. Replace Power Supply. 3. Measure voltages through I/O Power Cable. Replace I/O Power Cable. 4. Replace Processor.
R/P	OFF	ON	OFF	ON	1. Connect Industrial Terminal to Processor. 2. Correct run-time error.
R/P	ON	ON	OFF	ON	1. Turn Mode Select Switch to PROG and back to RUN/PROG. 2. Replace Processor.
<p>[1] T = TEST POSITION R = RUN POSITION R/P = RUN/PROGRAM POSITION</p>					



**Figure 5.2**  
Power Supply/Power Cable Outputs



10143-I

2. Remove system power at the main disconnect
3. Remove wiring from the Power Supply's terminal strip.
4. Remove I/O Power Cable from the base of Power Supply.
5. Remove the Power Supply from its mounting and install a replacement Power Supply. Be sure that the correct Power Supply fuse is installed in the fuseholder and that the terminal strip is jumpered according to the line voltage.
6. Connect the terminal strip wiring and the I/O Power Cable to the Power Supply.
7. Restore system power.

### Mini-PLC-2/15 Processor

There are three indicators on the Processor that are used during troubleshooting to help determine the source of a fault. They reflect the status of the processor's self-checking routines and errors in programming. These indicators are:

- PROCESSOR
- MEMORY
- RUN

Two types of faults that can occur with the Mini-PLC-2/15 Processor are processor faults and run-time errors. A processor fault can be any hardware fault or other fault that is internal to the Processor. A run-time error is simply a programming error that is detected by the Processor while the program is operating.

If a processor fault or a run-time error is detected, either or both the PROCESSOR and MEMORY indicators will illuminate depending on the

AB DRIVES

nature of the problem. The possible combinations of indicator status are summarized in Table 5.B.

### **Processor Faults and Run-Time Errors**

Any time the PROCESSOR indicator goes ON by itself during operation, this indicates that a hardware fault in the Processor has occurred. The only way to correct this type of fault is by cycling line power using the main disconnect or by replacing the Processor.

Any time the MEMORY indicator goes ON by itself or with the PROCESSOR indicator, this can indicate either a processor fault or a run-time error. The first step in diagnosing the fault is to connect the 1770-T3 Industrial Terminal to the Processor. Once connected and turned ON, the Industrial Terminal will display a message that identifies the fault as a processor fault or a run-time error.

If both indicators are illuminated, the processor fault can be corrected by turning the Mode Select Switch to PROG and back to RUN or RUN/PROG or by replacing the Processor.

If the fault is a run-time error, press [1][1] for PLC-2 mode. The Industrial Terminal will display the rung and intensify the instruction where the run-time error occurred. This instruction could be the cause or the effect of the programming error. In addition, the type of run-time error will be described near the bottom of the screen.

### **Correcting Run-Time Errors**

Familiarity with the Mini-PLC-2/15 instruction set is required for correcting errors in the program. All Mini-PLC-2/15 instructions are described in the Programming and Operations Manual (Publication 1772-84). Refer to this Manual as needed for information on the program instructions and correcting run-time errors.

Run-time errors are corrected with the Processor in the PROG or REMOTE PROG mode. If the error occurred with the Processor in the RUN/PROG mode, connecting the Industrial Terminal will automatically place the Processor in REMOTE PROG mode. If the Processor is in the RUN mode, the Mode Select Switch must be changed to the PROG position to make the correction.

When a programmed EPROM is in place in the Processor, follow these procedures to make corrections to the program.

**CAUTION:** When removing the Mini-PLC-2/15 Processor from the I/O Chassis, always remove system power and I/O power first. This will avoid damage to the Processor Module's circuitry.

- 
1. Turn Mode Select Switch to the PROG position.
  2. Connect an external battery pack to the Processor (Figure 4-4).
  3. Remove AC power and I/O power.
  4. Remove the Processor from the I/O Chassis and remove the EPROM.
  5. Install a blank EPROM in the Processor (Section titled EPROM Installation, chapter 3). If a blank EPROM is not available, erase the existing one and reinstall it. See Publication 1770-915 for erasing details.
  6. Install the Processor in the I/O Chassis.
  7. Restore AC power.
  8. Disconnect the external battery pack from the Processor.
  9. Connect the 1770-T3 Industrial Terminal and correct the run-time error.
  10. Verify proper operation.
  11. Program the EPROM (Section 4.3.2).

### **Mini-PLC-2/15 Processor Replacement**

If the Processor is the suspected source of a fault, perform the following steps to replace it:

**CAUTION:** when removing the Mini-PLC-2/15 Processor from the I/O Chassis, always remove system power and I/O power first. This will avoid damage to the Processor Module's circuitry.

- 
1. Turn the Mode Select Switch to the PROG position.
  2. Verify that a copy of the User Program is stored on an EPROM or magnetic tape.
  3. Remove AC power and I/O power.

4. Remove the Processor from the I/O Chassis.
5. Remove the EPROM if installed in the Processor and install it in the replacement Processor if necessary.
6. Install the replacement Processor in the I/O Chassis and turn the Mode Select Switch to the PROG position.
7. Restore AC power and I/O power.
8. Load the User Program and verify proper operation.

If an EPROM is used, it will transfer its content into RAM memory when power is restored. If the transfer was not successful, the MEMORY indicator will illuminate. In this case, replace the EPROM with a blank one and load the User Program into memory from magnetic tape.

Then program the EPROM after the User Program is verified.

## **1771 I/O Modules**

The I/O Modules are powered by the 5.1V DC signal carried across the backplane to the backplane connectors. The I/O devices connected to the Module's Field Wiring Arms are usually powered by an I/O power source.

If the output devices do not behave as programmed, yet the User Program is correct and all diagnostic indicators imply normal operation, the source of the fault could be:

- Shorted wiring or open circuit to the output device
- Blown Output Module fuse
- I/O Module not correctly seated in Chassis
- Malfunctioning Output Module
- Wiring connected to wrong Field Wiring Arm terminal
- Faulty I/O device
- Faulty I/O power source

Follow the procedures as described in the troubleshooting flowchart to help determine the source of the fault.

### **Output Module Fuse Replacement**

If the FUSE BLOWN indicator on any of the Output Modules is illuminated, one or more Output Module fuses is blown. Perform the following steps to replace a blown Output Module fuse:

**CAUTION:** Replacement fuses must be the correct type and rating. Using the wrong fuse can result in damage to equipment or Module circuitry.

---

**WARNING:** Contact with AC line potentials may cause injury to personnel. Removing power from the System Power Supply does not remove the external power source supplying the Field Wiring Arm. Failure to remove this external power source causes voltage to be present at Field Wiring Arm terminals.

---

1. Place Mini-PLC-2/15 Processor in the PROG mode and support memory.
2. Remove system power and I/O power.
3. Correct the cause of the blown fuse.
4. Remove the Output Module.
5. Remove the two fuse cover screws as shown in Figure 5.3.
6. Carefully remove the cover on the reverse side of these two screws.
7. Remove the blown fuse and install a replacement fuse (Figure 5.4).
8. Install the front fuse cover and screw in place on the Module.
9. Install the Module in the Chassis and restore system and I/O power.

### **I/O Module Replacement**

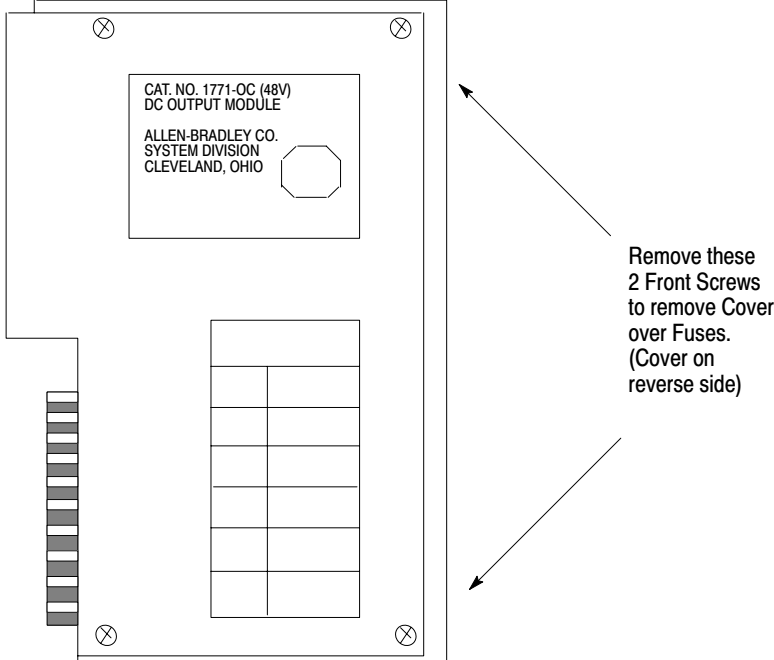
If the I/O Module is the suspected source of the fault, it should be replaced with the identical type and compatible series Module. Perform the following steps to replace the I/O Module:

**WARNING:** Contact with AC line potentials may cause injury to personnel. Removing power from the System Power Supply does not remove the external power source supplying the Field Wiring Arm. Failure to remove this external power source causes voltage to be present at the Field Wiring Arm terminals.

---

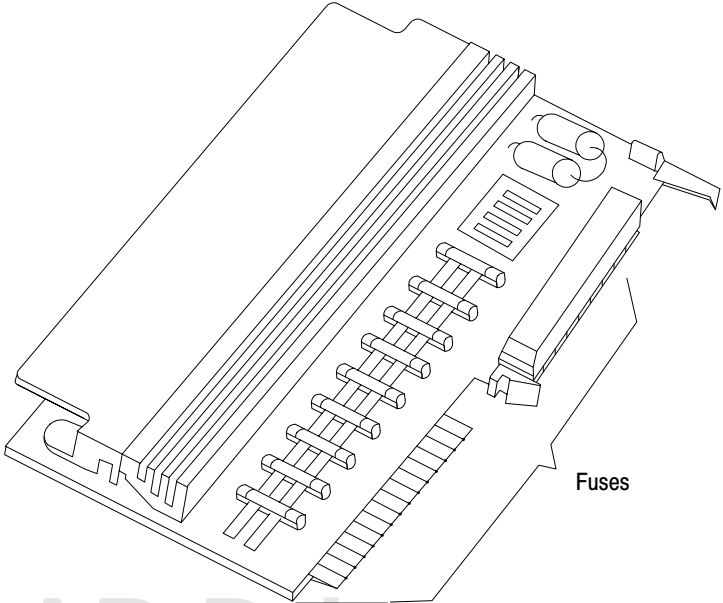
1. Place the Mini-PLC-2/15 Processor in the PROG mode.
2. Support Processor memory if necessary.
3. Remove system power and I/O power.
4. Remove the I/O Module and install the replacement Module. Be sure it is the same type and series level as the one removed.
5. Restore system and I/O power.

**Figure 5.3**  
Removing Fuse Access Cover



10705-1

**Figure 5.4**  
Output Module Fuses



AB Drives

10779-1

## Specifications

### General

This section contains physical, electrical and functional information on each Mini-PLC-2/15 Controller component. The following are overall specifications for this equipment:

#### Ambient Temperature Rating

Operational: 0<sup>o</sup> to 60<sup>o</sup>C (32<sup>o</sup> to 140<sup>o</sup>F)  
Storage: -40<sup>o</sup> to 85<sup>o</sup>C (-40<sup>o</sup> to 185<sup>o</sup>F)

#### Humidity Rating

5 to 95% (without condensation)

#### Input Voltage (nominal)

120V AC, 50/60 Hz  
220/240V AC, 50/60 Hz

### Mini-PLC-2/15 Processor

The Mini-PLC-2/15 Processor Module has the following specifications:

#### Memory Size

2048 (2K) words

#### Memory Type

CMOS RAM; optional 2K EPROM backup

#### Data Table Size

Up to 1920 words

#### Word Length

16 data bits plus 2 parity bits  
(8 data bits and 1 parity bit per byte)

#### Execution Time

(nominal)5 msec/1K memory

#### Weight

2 lb 12 oz/1.25 Kg

#### Current Requirement

2A



## System Power Supply

**Input Voltage Range**

98–132V AC (120V AC operation)  
196–250V AC (220/240V AC operation)

**Frequency Range**

50/60 Hz (47–63 Hz)

**Output Voltage**

+5.1V DC (logic circuitry)  
+5V DC (memory)

**Maximum Output Current**

6.5 amps

**Input Power**

75 VA (approx.)

**Power Capability**

One Mini-PLC-2/15 Processor and One 1771 I/O Rack (128 I/O)

**Location**

Side plate of Bulletin 1771 I/O Chassis or up to 5 cable-feet above I/O Chassis

**Battery Type**

2 Alkaline D-size 1.5V or Lithium D-size 3.4V

**Weight**

13 lbs/5.85 Kg

**Dimensions (WxHxD)**

4.56 x 11.25 x 7.16 inches  
11.6 x 28.5 x 18.2 cm

**Fuse**

120V use: 1A slow blow  
Bussmann: MDL 1  
Littlefuse: 313001  
220/240V use: 0.5A slow blow  
Bussmann: MDL 1/2  
Littlefuse: 313.500

## **I/O Equipment**

The following are summary specifications for Bulletin 1771 I/O Chassis. For specifications on individual I/O modules, refer to the product data sheets.

### **Chassis Dimensions (WxHxD)**

Inches

32 I/O: 9.15 x 11.25 x 6.75

64 I/O: 14.15 x 11.25 x 6.75

128 I/O: 24.15 x 11.25 x 6.75

Centimeters

32 I/O: 23.24 x 28.58 x 17.15

64 I/O: 35.94 x 28.58 x 17.15

128 I/O: 61.32 x 28.58 x 17.15

### **Chassis Sizes**

32 I/O, Cat. No. 1771-A1,  
contains 4 I/O slots (2 Modules Groups)

64 I/O, Cat. No. 1771-A2,  
contains 8 I/O slots (4 Module Groups)

128 I/O, Cat. No. 1771-A4,  
contains 16 I/O slots (8 Module Groups)

## **Industrial Terminal**

The Industrial Terminal System (Cat. No. 1770-T3 has the following specifications:

Input Voltage (nominal)

**120V AC220/240V AC**

### **Input Voltage Range**

98-132V AC (120V AC operation)

196-250V AC (220/240V AC  
operation)

### **Frequency range**

0/60 Hz (47-63 Hz)

### **Fuse**

1A/120V AC

Bussmann: AGC 1

Littlefuse: 312001

0.5A 220/240V AC

Bussmann: AGC 1/2Littlefuse:

312.005

### **Ambient Temperature Rating**

Operational: 0o to 55oC (32o to 130 F)

Storage: -40o to 65oC (-40o to 149oF)

### **Humidity Rating**

5 to 95% (without condensation)

### **Dimensions (WxHxD)**

14.5 x 10 x 23 inches

36.8 x 25.4 x 58.4 centimeters

### **Weight**

35 lbs (15.9 kg)

## Symbols

\*\*Empty\*\*, [5-1](#), [5-4](#)

## A

### AC

Input Fuse, [2-5](#)

Wiring, [3-33](#)

Access, EPROM, [2-11](#)

Address, Five Digit, [2-14](#)

Addressing, I/O, [2-13](#)

Alkaline Battery, [3-15](#)

### Assembly

Chassis, [3-11](#)

I/O Chassis, [3-11](#)

Switch Group, [3-12](#)

Attaching Field Wiring Arm, [3-26](#)

## B

Background, [1-2](#)

### Battery Pack

Description, [2-4](#)

Installation, [3-13](#)

## C

### Cable

Power, I/O, [2-4](#), [3-22](#)

Shield Connection, [3-33](#)

### Chart

Module, [2-5](#)

Troubleshooting, [5-10](#)

Chassis, Mounting, [3-17](#)

Chassis, Assembly, [3-11](#)

### Checkout

Final, [4-7](#)

Machine motion, [4-7](#)

Power up, [4-2](#)

Prepower, [4-2](#)

Comparison, Indicators, [4-3](#)

### Component

Grounding, [3-8](#)

Spacing, [3-6](#)

Concepts, [1-1](#)

Controller, [2-2](#)

Run-Time Errors, [5-12](#)

## D

Definition, [1-1](#)

### Description

AC Input Fuse, [2-5](#)

Battery Pack, [2-4](#)

Diagnostic Indicators, [2-8](#)

Field Wiring Arms, [2-12](#)

I/O Modules, [2-11](#)

I/O Power Cable, [2-4](#)

Industrial Terminal, [2-14](#)

INTERFACE Socket, [2-11](#)

Memory Write Protect, [2-11](#)

Mode Select Switch, [2-10](#)

Optional Power Supply, [2-7](#)

Power Supply, [2-1](#)

Processor, [2-8](#)

Terminal Strip, [2-6](#)

Description, I/O Chassis, [2-7](#)

Diagnostic Indicators, [2-8](#)

## E

Enclosure, [3-6](#)

Environmentl Considerations, [3-1](#)

### EPROM

Access Door, [2-11](#)

Installation, [3-20](#)

Equipment, User Supplied, [2-14](#)

## F

Faults, Processor, [5-12](#)

Field Wiring Arm, Description, [2-12](#)

### Field Wiring Arms

Consdierations, [3-26](#)

Considerations, [3-23](#)

Guidelines, [3-23](#), [3-27](#)

Five-digit Address, [2-14](#)

### Fuse

Replacement, [5-9](#)

Replacement, Output Module, [5-15](#)

Replacement, Power Supply, [5-3](#)

Voltage Measurements, [5-4](#)

**G**

Ground  
Component, [3-8](#)  
Enclosure, [3-6](#)  
General, [3-8](#)

**I**

I/O  
Chassi, Pre-Assembly, [3-11](#)  
Chassis, Assembly, [3-18](#)  
Chassis, Sizes, [2-8](#)  
Module, Description, [2-11](#)  
Module, Installation, [3-20](#)  
Module, Replacement, [5-16](#)  
Module, Typical, [2-12](#)  
Power Cable, [2-4](#)  
Wiring, [3-23](#)  
I/O Power cable, [3-19](#)  
Industrial Terminal  
Description, [2-14](#)  
Status Indicators, [4-2](#)  
Installation, [1-2](#)  
Battery Pack, [3-13](#)  
EPROM, [3-20](#)  
I/O Power Cable, [2-4](#)  
Keying bands, [3-16](#)  
Processor, [3-23](#)  
Recommendations, [3-1](#)

**K**

Keying Bands, [3-16](#)

**M**

Machine Motion, Checkout, [4-7](#)  
Measurement, Power Supply Voltage, [5-4](#)  
Memory Write Protect, [2-11](#)  
Mode Select Switch, [2-10](#)  
Module  
Chart, [2-5](#)  
Groups, [2-15](#)  
Motion, Machine, [4-7](#)  
Mounting  
I/O Chassis, [3-17](#)  
Power Supply, [3-17](#)

**O**

Optional Power Supply, [2-7](#)

**P**

Power Supply  
Checkout, [4-2](#)  
Fuse Replacement, [5-3](#)  
Indicators, [2-6](#)  
Specifications, [6-1](#)  
Troubleshooting, [5-1](#)  
Power Supply, Description, [2-6](#)  
Prepower Checkout, [4-1](#), [4-2](#)  
Preventive Maintenance, [5-1](#)  
Processor  
Faults, [5-12](#)  
Replacement, [5-13](#)  
Troubleshooting, [5-10](#)

**R**

Replacement  
Fuse (output supply), [5-11](#)  
Fuse (Power Supply), [5-3](#)  
Power Supply, [5-4](#)  
Processor, [5-13](#)  
Run Time Error, [5-12](#)

**S**

Sizes, I/O Chassis, [2-8](#)  
Spacing, Components, [3-6](#)  
Spare Parts, [5-1](#)  
Specifications  
General, [6-1](#)  
I/O, [6-3](#)  
Industrial Terminal, [4-2](#), [6-3](#)  
Processor, [6-1](#)  
Startup, [4-1](#)  
Storage, Program, [4-8](#)

**T**

Terminal Strip, Description, [2-6](#)

**Troubleshooting**General, [5-1](#)Power Supply, [5-2](#)Processor, [5-11](#)**V**Voltage Measurement, Power Supply, [5-4](#)**U**User Supplied Equipment, [2-14](#)



**ALLEN-BRADLEY**  
A ROCKWELL INTERNATIONAL COMPANY

Allen-Bradley has been helping its customers improve productivity and quality for 90 years. A-B designs, manufactures and supports a broad range of control and automation products worldwide. They include logic processors, power and motion control devices, man-machine interfaces and sensors. Allen-Bradley is a subsidiary of Rockwell International, one of the world's leading technology companies.



With major offices worldwide.

Algeria • Argentina • Australia • Austria • Bahrain • Belgium • Brazil • Bulgaria • Canada • Chile • China, PRC • Colombia • Costa Rica • Croatia • Cyprus • Czech Republic • Denmark • Ecuador • Egypt • El Salvador • Finland • France • Germany • Greece • Guatemala • Honduras • Hong Kong • Hungary • Iceland • India • Indonesia • Israel • Italy • Jamaica • Japan • Jordan • Korea • Kuwait • Lebanon • Malaysia • Mexico • New Zealand • Norway • Oman • Pakistan • Peru • Philippines • Poland • Portugal • Puerto Rico • Qatar • Romania • Russia-CIS • Saudi Arabia • Singapore • Slovakia • Slovenia • South Africa, Republic • Spain • Switzerland • Taiwan • Thailand • The Netherlands • Turkey • United Arab Emirates • United Kingdom • United States • Uruguay • Venezuela • Yugoslavia

World Headquarters, Allen-Bradley, 1201 South Second Street, Milwaukee, WI 53204 USA, Tel: (1) 414 382-2000 Fax: (1) 414 382-4444