

## NetLinx ControlNet 1784-PCIC Communication Card

Catalog Number 1784-PCIC

This document describes how to install and use the NetLinx 1784-PCIC ControlNet™ communication interface card.

Topic:	Page:
Important User Information	2
About the Application Software	3
European Communities (EC) Directive Compliance	5
Install the Card Inside the Computer	7
Connect the Card	9
1784-PCIC Drivers	14
Interpret the Status Indicators on the 1784-PCIC	14
CSA Hazardous Location Approval	16
Specifications	18

If you connect the card directly to a ControlNet COAX network, you also need to use:

- ControlNet Tap Installation Instructions, publication 1786-5.7
- ControlNet Cable Planning and Installation Manual, publication 1786-6.2.1

The 1784-PCIC communication interface card lets a PCI Local bus compatible computer communicate directly with other ControlNet products.

## Important User Information

Because of the variety of uses for the products described in this publication, those responsible for the application and use of this control equipment must satisfy themselves that all necessary steps have been taken to assure that each application and use meets all performance and safety requirements, including and applicable laws, regulations codes and standards.

The illustrations, charts, sample programs and layout examples shown in this guide are intended solely for purposes of example. Since there are many variables and requirements associated with any particular installation, Allen-Bradley does not assume responsibility or liability (to include intellectual property liability) for actual use based upon the examples shown in this publication.

Allen-Bradley publication SGI-1.1, *Safety Guidelines for the Application, Installation, and Maintenance of Solid State Control* (available from your local Allen-Bradley office), describes some important differences between solid-state equipment and electromechanical devices that should be taken into consideration when applying products such as those described in this publication.

Reproduction of the contents of this copyrighted publication, in whole or in part, without written permission of Rockwell Automation is prohibited.

Throughout this document we use notes to make you aware of safety considerations:



**ATTENTION:** Identifies information about practices or circumstances that can lead to personal injury or death, property damage or economic loss.

---

Attention statements help you to:

- identify a hazard
- avoid a hazard
- recognize the consequences

**Important:** Identifies information that is critical for successful application and understanding of the product.

Allen-Bradley is a trademark of Rockwell Automation.

## About the Application Software

The Allen-Bradley standard application programming interface (API) is RSLinx™ software from Rockwell Software Inc. Contact your local Rockwell Automation sales representative or distributor for further information.

## Rockwell Automation Support

Rockwell Automation offers support services worldwide, with over 75 sales/support offices, over 500 authorized distributors, and 260 authorized systems integrators located throughout the United States alone, plus Rockwell Automation representatives in every major country around the world. Contact your local Rockwell Automation representative for:

- sales and order support
- product technical training
- warranty support
- support service agreements

## Obtain Pre-Sales Product Support

If you need to contact Rockwell Automation for pre-sales product support, try one of the following methods:

- Call your local Rockwell Automation representative
- Network Pre-sales support line, 1.440.646.3638 (3NET)
- Pre-Sales e-mail, [RACle3net@ra.rockwell.com](mailto:RACle3net@ra.rockwell.com)

## Obtain Technical Product Support

If you need to contact Rockwell Automation for technical assistance, try one of the following methods:

- Call your local Rockwell Automation representative
- Post-Sales Technical Support, 1.440.646.5800
- Fax Back system, 1.440.646.5436 (requires a touch-tone telephone)
- Web Links     <http://www.ab.com> — as a registered member, open to <http://www.ab.com/mem/technotes/techmain.html>

## European Communities (EC) Directive Compliance

If this product has the CE mark it is approved for installation within the European Union and EEA regions. It has been designed and tested to meet the following directives.

### EMC Directive

This product is tested to meet the Council Directive 89/336/EC Electromagnetic Compatibility (EMC) by applying the following standards, in whole or in part, documented in a technical construction file:

- EN 50081-2 EMC — Generic Emission Standard, Part 2 — Industrial Environment
- EN 5001082-2 EMC — Generic Immunity Standard, Part 2 — Industrial Environment

This product is intended for use in an industrial environment.

### Low Voltage Directive

This product is tested to meet Council Directive 73/23/EEC Low Voltage, by applying the safety requirements of EN 61131-2 Programmable Controllers, Part 2 - Equipment Requirements and Tests. This equipment is classified as open equipment and must be mounted in an enclosure during operation to provide safety protection.

For specific information required by EN 61131-2, see the appropriate section in the following Allen-Bradley publications:

- Industrial Automation Wiring and Grounding Guidelines, publication 1770-4.1
- Automation Systems Catalog, publication B111

## Handling the Card

---



**ATTENTION:** The card uses CMOS technology, which is highly sensitive to electrostatic discharge (ESD). ESD may be present whenever you handle the card. When you handle the card without any ESD protection you can cause internal circuit damage that may not be apparent when you install or initially use the card.

---

Take these precautions to guard against ESD damage:

- Before you handle the card, touch a grounded object to discharge and built-up static charge.
- Avoid touching the backplane connector or interface connector pins located on the card.
- If the card is not in use, store it in the anti-static clamshell that the card was shipped in.

**Important:** Remember, a computer with ac power disconnected is *not* a grounded object.

## Install the Card Inside the Computer

Before you install the card, be certain you know how to:

- install hardware in your computer
- configure the computer's options such as: disable cache memory, memory manager, and shadowing of memory, before you install the card.

Consult your computer's documentation for specific information.

To install the card, you need to:

- access to the computer's expansion slots
- possess either a Phillip-head or a flat-head screwdriver
- insert the card into the computer

### Access the Computer's PCI Local Bus Expansion Slots

To install the card, you must access the computer's PCI local bus expansion slots. Follow these general steps, or refer to your computer's user guide for instructions on how to:

1. Turn off the power to the host computer with the power switch.
2. Remove the computer's cover.
3. Select a vacant PCI local bus expansion slot.
4. Remove the slot's expansion cover. Loosen the screw on the back (rear bracket) of the computer.

## Insert the Card

To insert the card inside the computer:

1. Follow the card handling instructions on page 6.
2. Insert the card into the edge connector and tighten the expansion slot screw.
3. Turn on the computer to be certain that it comes up correctly.

<b>If the computer:</b>	<b>then:</b>
powers up	go to step 4
hangs up	<ul style="list-style-type: none"><li>• you probably have a memory or I/O conflict</li><li>• you should remove all other cards and try again</li></ul> If you continue to experience difficulty, contact your local Rockwell Automation sales representative or distributor, or call Rockwell Automation Technical Support at 440.646.5800.

4. Replace the computer's cover (when the computer boots up correctly).



## Connect the Card

After you have installed the card, you can connect it to:

- to a device already connected to the ControlNet network (page 10)
- directly to a ControlNet network, which requires a tap (page 13)

Figure 1 describes the 1784-PCIC card connectors and indicators.

Figure 1 1784-PCIC card

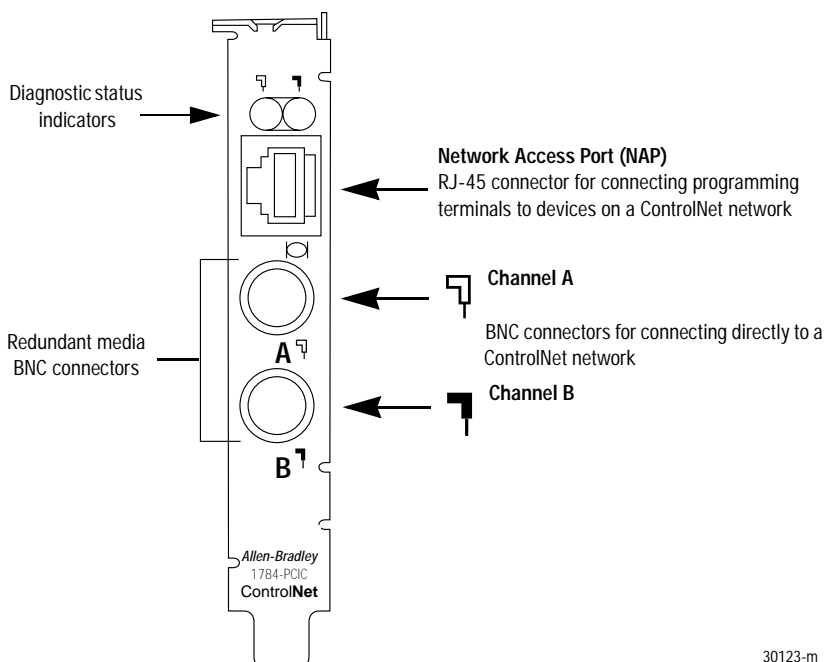

**ATTENTION:** Do not use the card to connect to more than one network at a time. If you attempt to connect to a second network your communication system will operate erratically.

See page 14 for information about status indicators. Indicators diagnose only redundant media BNC connections.

**Important:** If you use a non-redundant cable system, all ControlNet devices must be on the same channel, channel A.

### Connect to a Device on the ControlNet Network

The 1786-CP cable (Figure 2) connects a host computer to another ControlNet device. It has two RJ-45 8 pin connectors.

Figure 2 1786-CP cable

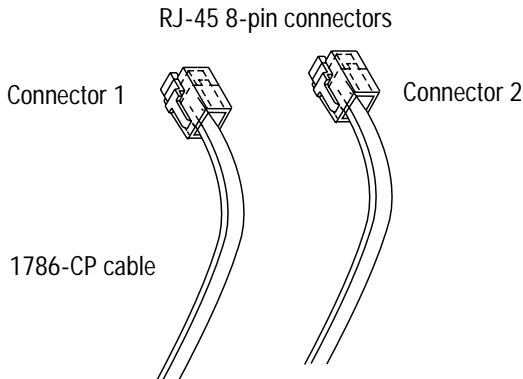

30124-m



**ATTENTION:** Use the **1786-CP** cable when you connect a programming terminal to the network through the network access port (NAP). If you use another cable it could result in possible network failures or product damage.

---

Table A shows the wiring for the cable.

**Table A Wiring for 1786-CP connector cable**

<b>Connector 1</b>		
<b>Wire Number</b>	<b>Signal Mnemonic</b>	<b>Signal Name</b>
1	ISO-GND	Isolated Ground
2	N.C.	No Connection
3	PTTX-H	Transmit Data High
4	PTTX-L	Transmit Data Low
5	PTRX-L	Receive Data Low
6	PTRX-H	Receive Data High
7	N.C.	No Connection
8	ISO-GND	Isolated Ground

<b>Connector 2</b>		
<b>Wire Number</b>	<b>Signal Mnemonic</b>	<b>Signal Name</b>
1	ISO-GND	Isolated Ground
2	N.C.	No Connection
3	PTRX-H	Receive Data High
4	PTRX-L	Receive Data Low
5	PTTX-L	Transmit Data Low
6	PTTX-H	Transmit Data High
7	N.C.	No Connection
8	ISO-GND	Isolated Ground

When you use the RJ-45 connector you can connect the card to a ControlNet network, without a tap, through the Network Access Port (or NAP) of a programmable controller, I/O adapter, or other ControlNet compliant devices (Figure 3 and Figure 4).

**Figure 3** Connect a computer to a ControlNet network through a programmable controller or an I/O adapter

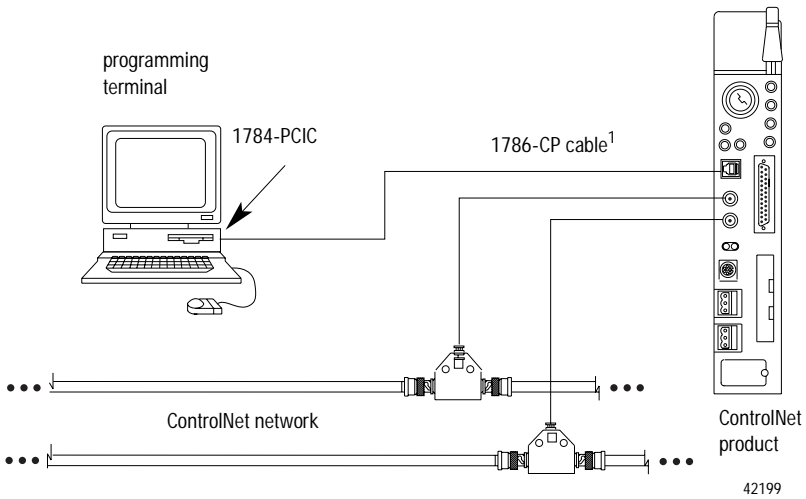

- 1 The 1786-CP cable can be plugged into any ControlNet product's NAP to provide programming capability on the ControlNet network. When you connect a programming terminal through this cable, it is counted as a node and must have a unique address.



**ATTENTION:** If you connect the product to a cable system that does not support redundant media, connect the tap dropline to the BNC connector labeled channel A. Channel B is left open.

If the cable system is redundant, connect the product so that all devices on the network use the same cable for the same channel. That is, all channel A connectors connect to one cable; all channel B connectors connect to the other.

**Figure 4** Connect a portable host computer to ControlNet through the 1784-PCIC card

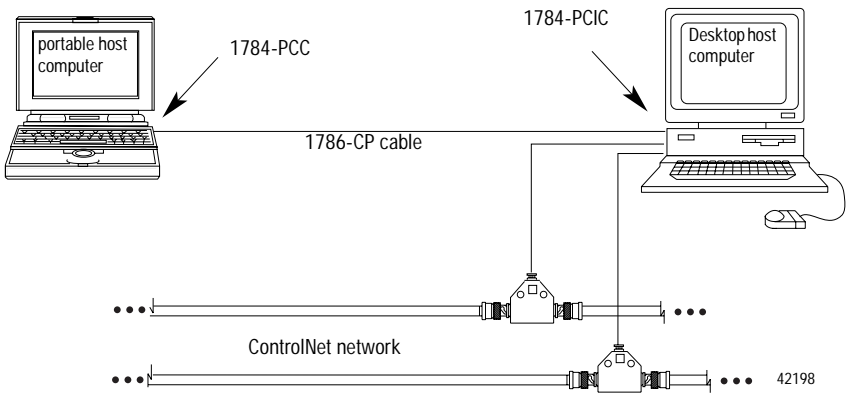

### Connect the Card Directly to the ControlNet Network

To connect the card directly to a ControlNet network as shown in Figure 5, follow the instructions in these publications:

- ControlNet Tap Installation Instructions, publication 1786-5.7
- ControlNet Cable Planning and Installation Manual, publication 1786-6.2.1

**Figure 5** Connect the card directly to the ControlNet network

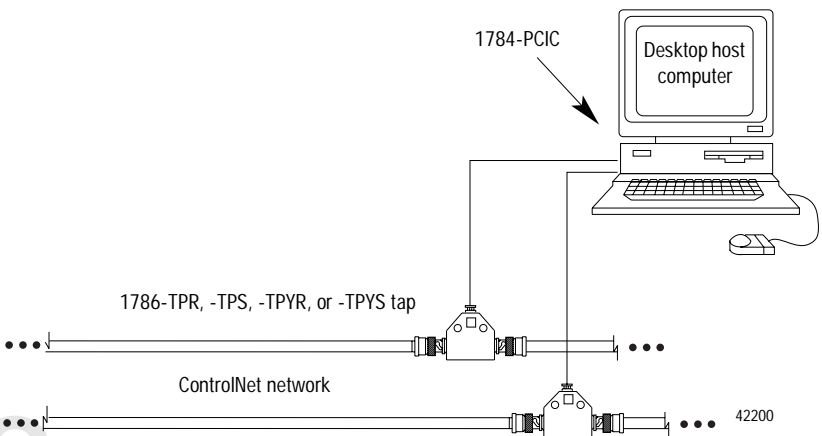

## 1784-PCIC Drivers

The device drivers for the 1784-PCIC card ship with Rockwell Software's RSLinx release 2.2 or later. A hot fix for RSLinx release 2.1 is also available.



Refer to online Help in RSLinx for information on configuring a driver for the 1784-PCIC card. See page 4 for technical support information.

## Interpret the Status Indicators on the 1784-PCIC

The status indicators on the card give you information about the card and the network when you're connected via the BNC connectors. Table B outlines the states and explains what each state means to you and the action you should take, if any, to correct that state.

**Table B**  
**ControlNet status interpretation**

- **steady** - indicator is on continuously in the defined state.
- **alternating** - the two indicators alternate between the two defined states at the same time (applies to both indicators viewed together). The two indicators are always in opposite states, out of phase.
- **flashing** - the indicator alternates between the two defined states (applies to each indicator viewed independent of the other). If both indicators flash, they must flash together, in phase.

 A and  B	Cause:	Action:
off	<ul style="list-style-type: none"> <li>• no power</li> </ul>	<ul style="list-style-type: none"> <li>• none or apply power</li> </ul>
steady red	<ul style="list-style-type: none"> <li>• faulted unit</li> </ul>	<ul style="list-style-type: none"> <li>• cycle power or reset unit</li> <li>• If fault persists, contact your Rockwell Automation representative or distributor.</li> <li>• See page 4 for technical support information.</li> </ul>
alternating red/green	<ul style="list-style-type: none"> <li>• self-test</li> </ul>	<ul style="list-style-type: none"> <li>• none</li> </ul>
alternating red/off	<ul style="list-style-type: none"> <li>• incorrect node configuration</li> <li>• duplicate ControlNet node address</li> </ul>	<ul style="list-style-type: none"> <li>• check network address and other ControlNet configuration parameters</li> </ul>
off	<ul style="list-style-type: none"> <li>• channel disabled</li> </ul>	<ul style="list-style-type: none"> <li>• program network for redundant media, if required</li> </ul>
steady green	<ul style="list-style-type: none"> <li>• normal operation</li> </ul>	<ul style="list-style-type: none"> <li>• none</li> </ul>
flashing green/off	<ul style="list-style-type: none"> <li>• temporary errors</li> <li>• node is not configured to go on line</li> </ul>	<ul style="list-style-type: none"> <li>• none; unit will self-correct</li> <li>• be certain that the keeper node is present and working <sup>1</sup></li> </ul>
flashing red/off	<ul style="list-style-type: none"> <li>• media fault</li> <li>• no other nodes present on network</li> </ul>	<ul style="list-style-type: none"> <li>• check media for broken cables, loose connectors, missing terminators, etc.</li> <li>• add other nodes to the network</li> </ul>
flashing red/green	<ul style="list-style-type: none"> <li>• incorrect network configuration</li> </ul>	<ul style="list-style-type: none"> <li>• cycle power or reset unit</li> <li>• If fault persists, contact your Rockwell Automation representative or distributor.</li> </ul>

<sup>1</sup> The keeper node is responsible for distributing ControlNet configuration data to all nodes on the network.

**Important:** When you connect the module to a ControlNet network using the network access port (NAP) only, the LEDs are meaningless.

## CSA Hazardous Location Approval

CSA certifies products for general use as well as for the use in hazardous locations. **Actual CSA certification is indicated by the product label** as shown below, and not by statements in any user documentation.

Example of the CSA certification product label



CL 1 DIV 2  
GP A,B,C,D  
TEMP



To comply with CSA certification for use in hazardous locations, the following information becomes a part of the product literature for this CSA-certified industrial control product.

- This equipment is suitable for use in Class 1, Division 2, Groups A, B, C, D, or non-hazardous locations only.
- The products having the appropriate CSA markings (that is, Class 1, Division 2, Groups A, B, C, D), are certified for use in other equipment where the suitability of combination (that is, application or use) is determined by the CSA or the local inspection office having jurisdiction.

**Important:** Due to the modular nature of a programmable control system, the product with the highest temperature rating determines the overall temperature code rating of a programmable control system in a Class 1, Division 2 location. The temperature code rating is marked on the product label as shown.

Temperature code rating



CL 1 DIV 2  
GP A,B,C,D  
TEMP



← Look for temperature code rating here

The following warnings apply to products having CSA certification for use in hazardous locations.



### **WARNING:** Explosion hazard

- Substitution of components may impair suitability for Class 1, Division 2.
- Do not replace components unless power has been switched off or the area is known to be non-hazardous.
- Do not disconnect equipment unless power has been switched off or the area is known to be non-hazardous.
- Do not disconnect connectors unless power has been switched off or the area is known to be non-hazardous. Secure any user-supplied connectors that mate to external circuits on this equipment by using screws, sliding latches, threaded connectors, or other means such that any connection can withstand a 15 Newton (3.4lb.) separating force applied for a minimum of one minute.
- Batteries must be changed only in an area known to be non-hazardous.

CSA logo is a registered trademark of the Canadian Standards Association.



## Approbation d'utilisation dans des emplacements dangereux par la CSA

La CSA certifie les produits d'utilisation générale aussi bien que ceux qui s'utilisent dans des emplacements dangereux. **La certification CSA en vigueur est indiquée par l'étiquette du produit** et non par des affirmations dans la documentation à l'usage des utilisateurs.

Exemple d'étiquette de certification d'un produit par la CSA.



CL 1 DIV 2  
GP A, B, C, D  
TEMP



Pour satisfaire à la certification de la CSA dans des endroits dangereux, les informations suivantes font partie intégrante de la documentation ce produit industriel de contrôle certifié par la CSA.

- Cet équipement convient à l'utilisation dans des emplacements de Classe 1, Division 2, Groupes A, B, C, D, ou ne convient qu'à utilisation dans des endroits non dangereux.
- Les produits portant le marquage approprié de la CSA (c'est à dire, Classe 1, Division 2, Groupes A, B, C, D) sont certifiés à l'utilisation pour d'autres équipement où la convenance de combinaison (application ou utilisation) est déterminée par la CSA ou le bureau local d'inspection qualifié.

**Important:** Par suite de la nature modulaire du système de contrôle programmable, le produit ayant le taux le plus élevé de température détermine le taux d'ensemble du code de température du système de contrôle d'un programmable dans un emplacement de Classe 1, Division 2. Le taux du code de température est indiqué sur l'étiquette du produit.

Taux du code de température



CL 1 DIV 2  
GP A, B, C, D  
TEMP



Le taux du code  
température est indiqué ici

Les avertissements suivants s'appliquent aux produits ayant la certification CSA pour leur utilisation dans des emplacements dangereux.



### AVERTISSEMENT: Risque d'explosion

- La substitution de composants peut rendre ce matériel inacceptable pour les emplacements de Classe 1, Division 2.
- Couper le courant ou s'assurer que l'emplacement est désigné non dangereux avant de remplacer les composants.
- Avant de débrancher l'équipement, couper le courant ou s'assurer que l'emplacement est désigné non dangereux.
- Avant de débrancher les connecteurs, couper le courant ou s'assurer que l'emplacement est reconnu non dangereux. Attacher tous connecteurs fournis par l'utilisateur et reliés aux circuits externes de l'appareil à l'aide de vis, loquets coulissants, connecteurs filetés ou autres moyens permettant aux connexions de résister à une force de séparation de 15 Newtons (3,4 lb. - 1,5 kg) appliquée pendant au moins une minute.
- Afin d'éviter tout risque d'explosion, s'assurer que l'emplacement est désigné non dangereux avant de changer la batterie.

Le sigle CSA est la marque déposée de l'Association des Standards pour le Canada.

## Specifications

The operating parameters describe the environment within the PCIC's slot. Refer to the documentation for your computer for environmental requirements. The card should not exceed those specifications.

### General Specifications

Characteristic	Value
Power Requirements	5 V dc, 700 mA Maximum, Class 2
Conductor	Category 2  Use this conductor category information when you plan conductor routing as described in publication 1770-4.1, Industrial Automation Wiring and Grounding Guidelines.

### Environmental Specifications

	Operating	Nonoperating
Slot Temperature	0 to 50° C (32 to 122° F)	-40 to 85° C (-40 to 185° F)
Humidity	5 to 95% without condensation	5 to 95% without condensation
Vibration	10 th 150 Hz, constant .012 in displacement 10 to 150 Hz, constant 2.0G acceleration	not applicable
Shock	30G peak/11 ms	50G peak/11 ms

### Agency Certification

(when product or packaging is marked)



UL Recognized Industrial Control Component



Certified Component Process Control Equipment



Certified Component Class I, Division 2, Groups A, B, C, D



Marked for all applicable directives



**ControlNet™**  
CONFORMANCE TESTED

PLCs

DH+, FLEX I/O, PanelView, and PLC-5/40C are trademarks of Rockwell Automation. ControlNet is a trademark of ControlNet International. WINTelligent LINX and WINTelligent LINX Gateway are trademarks of Rockwell Software Inc. Ethernet is a registered trademark of Digital Equipment Corporation, Intel, and Xerox Corporation.

---

**Reach us now at [www.rockwellautomation.com](http://www.rockwellautomation.com)**

Wherever you need us, Rockwell Automation brings together leading brands in industrial automation including Allen-Bradley controls, Reliance Electric power transmission products, Dodge mechanical power transmission components, and Rockwell Software. Rockwell Automation's unique, flexible approach to helping customers achieve a competitive advantage is supported by thousands of authorized partners, distributors and system integrators around the world.

**Americas Headquarters**, 1201 South Second Street, Milwaukee, WI 53204, USA, Tel: (1) 414 382-2000, Fax: (1) 414 382-4444  
**European Headquarters SA/NV**, avenue Herrmann Debroux, 46, 1160 Brussels, Belgium, Tel: (32) 2 663 06 00, Fax: (32) 2 663 06 40  
**Asia Pacific Headquarters**, 27/F Citicorp Centre, 18 Whitfield Road, Causeway Bay, Hong Kong, Tel: (852) 2887 4788, Fax: (852) 2508 1846



**Rockwell  
Automation**

Publication 1784-5.40 - January 2000

PN 955138-54

© 2000 Rockwell International Corporation. Printed in the U.S.A.