



ALLEN-BRADLEY

1785 Enhanced PLC-5 Processors

(Cat. Nos. 1785-L11B, -L20B, -L30B, -L40B,
-L40L, -L60B, -L60L, -L80B)

System Overview

Allen-Bradley

Table of Contents

PLC-5 Processors	<u>2</u>
Multiple Programming Language Support	<u>2</u>
relay ladder logic	<u>3</u>
structured text	<u>5</u>
sequential function charts	<u>5</u>
Powerful Program Control Features main control programs	<u>6</u>
processor interrupt routines	<u>6</u>
PID algorithms	<u>6</u>
Password and Privilege System Protection	<u>7</u>
Advanced Math Functions	<u>7</u>
Coprocessing Options	<u>7</u>
Built-in Serial Port	<u>8</u>
Configurable Communication Port	<u>8</u>
Ethernet Processors	<u>9</u>
PLC-5 Ethernet Interface Module	<u>9</u>
Extended-local Processors	<u>10</u>
VME Processors	<u>10</u>
Selecting a Processor	<u>11</u>
Input/Output Selections	<u>12</u>
Selecting I/O	<u>15</u>
Selecting a Chassis	<u>19</u>
Selecting a Power Supply	<u>20</u>
Processor Options	<u>21</u>
EEPROM Module Memory	<u>21</u>

Expand System Fault Tolerance	<u>21</u>
Coprocessor Programming Flexibility	<u>21</u>
Integrating the System	<u>22</u>
RSView Man/Machine Interface Software	<u>22</u>
Open Architecture	<u>24</u>
SCADA Systems	<u>24</u>
Ethernet Network	<u>25</u>
ControlNet	<u>26</u>
DeviceNet	<u>27</u>
Using the Software	<u>28</u>
A.I. Series Features	<u>28</u>
Allen-Bradley Support	<u>29</u>
For More Information	<u>30</u>
What to Do Next	<u>31</u>
Preparing to Layout a PLC-5 System	<u>32</u>

Introducing PLC-5 Processors

Introducing the PLC-5 System

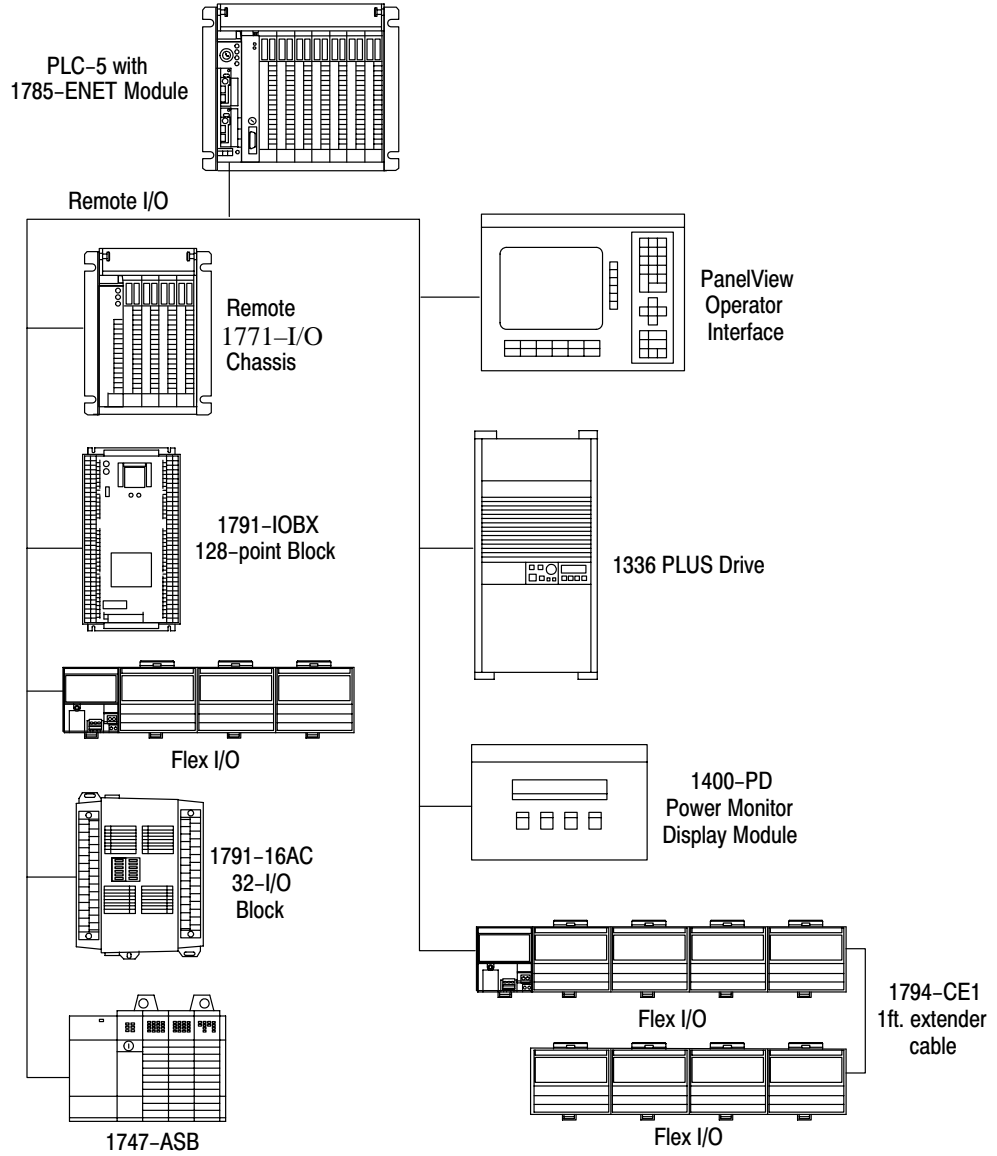

20063-M

PLC-5 processors are high-speed, single-slot processors you can use for control and information processing. These processors offer advanced programming features and versatile communication options to fit your unique application.

This book introduces Enhanced PLC-5 processors which include PLC-5/11, -5/20, -5/30, -5/40, -5/40L, -5/60, -5/60L, and -5/80 processors. We use the term PLC-5 processors to signify Enhanced PLC-5 processors.

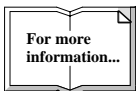

Keep in mind that PLC-5 processors are designed for larger sequential and regulatory control applications with specialized I/O requirements and/or the need to coordinate with other processors and devices. If your application is a simple analog or discrete one, requiring a smaller amount of I/O or memory, you may want to consider a SLC processor. For more information about SLC processors, see the SLC System Overview, publication 1747-2.30.

Using this Book

Use this book to approximate your needs and to begin to lay out a PLC-5 system that fits your particular application. With the help of this book, you'll see how easy it is to configure and use a PLC-5 system.

For information about:	See page:
processor features and capabilities	2
selecting a processor	11
input/output selections	12
selecting I/O	15
selecting a chassis	19
selecting a power supply	20
processor options	21
integrating a system	22
open architecture support	24
programming software	28
support services	29
preparing to layout a system	32



At the back of this book, we include guidelines to help you consider each option and to begin to lay out a system. Follow these guidelines as you move through each section of this book. If you need more information, please call your Allen-Bradley representative.

Introducing PLC-5 Processors

PLC-5 Processors

All PLC-5 processors share the following common features:

Multiple Programming Language Support
structured text, sequential function charts, ladder logic, function block

<p>Powerful Program Control Features 16 main control programs, time- and event-driven processor interrupt routines, PID algorithms</p>	<p>Built-in Communications RS-232/422/423, Data Highway Plus, Remote I/O Control Network, remote I/O communication distances up to 10,000 feet or 3,048 meters</p>
<p>Advanced Instruction Set includes basic and advanced ASCII string instructions, and advanced math functions</p>	<p>Program Execution Speed 0.5ms/k bit instructions, 2ms/k typical mix</p>
<p>System Protection passwords and privileges communication backup module</p>	

The next few pages describe these features. See page 11 to select a processor.

Environmental Conditions:

operating temperature: 0 to 60° C (32-140° F)
storage temperature: -40 to 85° C (-40 to 185° F)
relative humidity: 5-95% (without condensation)

Time of Day Clock and Calendar (battery backed):

maximum variations at 60° C: +/- 5 min per month
typical variations at 20° C: +/- 20s per month
timing accuracy: one program scan
Note: calendar updates appropriately each year,
including the year 2000

Agency Certification:

CSA certified, CSA Class I, Division 2,
Groups A, B, C, D, UL listed
CE marked for all applicable directives
(when product or packaging is marked)

Shock:

Operating: 30 g peak acceleration for 11±1 ms duration
Non-operating: 50 g peak acceleration for 11±1 ms duration

Vibration Testing (operating and non-operating):

1 g @ 10 to 500 Hz
0.012 inches peak-to-peak displacement

Location: 1771-I/O chassis, left-most slot

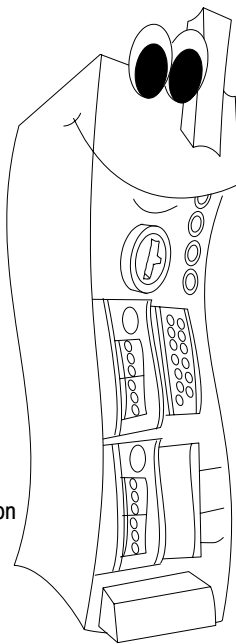

PLC-5 processor

Communication:

Data Highway Plus™ (trunk line: 3048 cable-m (10,000 cable-ft);
drop line: 30.4 cable-m (100 cable-ft)
Data Highway (DH) using 1785-KA
Serial
Ethernet (TCP/IP protocol, 15-pin AUI transceiver port)
remote I/O
extended-local I/O (PLC-5/40L and -5/60L processors only)

Backplane Current:

2.3A (PLC-5/11™, -5/20™, -5/30™)
3.3A (PLC-5/40™, -5/40L™, -5/60™, -5/60L™, -5/80™, -5/86™)
3.6A (PLC-5/20E™, -5/40E™, -5/80E™)

Processor Weights:









PLC-5/20, -5/26:	1.21 kg (2.7 lbs)
PLC-5/30:	1.20 kg (2.6 lbs)
PLC-5/40, -5/46, -5/40L:	1.42 kg (3.1 lbs)
PLC-5/60, -5/60L:	1.42 kg (3.1 lbs)
PLC-5/80, -5/86:	1.42 kg (3.1 lbs)

*Multiple Programming
Language Support*









PLC-5 processors support multiple industry-standard programming languages; you can program logic in IEC 1131-based structured text, function block, sequential function charts, or ladder logic. This versatility means you can maintain and troubleshoot programs in the same language that you develop them in.

relay ladder logic

All PLC-5 processors support the following built-in instructions:

<p>Relay</p> 	<p>Examine On (XIC) Examine Off (XIO) Energize (OTE) Latch (OTL) Unlatch (OTU)</p>	
<p>Sequence</p> 	<p>Sequencer Input (SQI) Sequencer Output (SQO) Sequencer Load (SQL) Smart Directed Sequencer (SDS) Diagnostic Fault Annunciator (DFA)</p>	
<p>Shift Register</p> 	<p>Bit Shift Left (BSL) Bit Shift Right (BSR)</p>	
<p>Compute</p> 	<p>Compute (CPT) Multiply (MUL) Negate (NEG) Sine (SIN) Square Root (SQR) Sort File (SRT) Subtract (SUB) Tangent (TAN) Arc Sine (ASN) Arc Cosine (ACS)</p>	<p>Log to the Base 10 (LOG) Natural Log (LN) Divide (DIV) Cosine (COS) Clear (CLR) Average File (AVE) Arc Tangent (ATN) Addition (ADD) Standard Deviation (STD) X to the Power of Y (XPY)</p>
<p>Conversion</p> 	<p>Convert to BCD (TOD) Convert from BCD (FRD) Degree (DEG) Radian (RAD)</p>	
<p>Timer/Counter</p> 	<p>Timer On Delay (TON) Timer Off Delay (TOF) Retentive Timer On (RTO) Count Up (CTU) Count Down (CTD) Timer and Counter Reset (RES)</p>	
<p>File</p> 	<p>File Arithmetic and Logic (FAL) File Search and Compare (FSC) File Copy (COP) File Fill (FLL)</p>	<p>FIFO Load (FFL) FIFO Unload (FFU) LIFO Load (LFL) LIFO Unload (LFU)</p>
<p>Logical</p> 	<p>AND NOT OR Exclusive Or (XOR)</p>	

Introducing PLC-5 Processors

<p>Compare</p> 	<p>Compare (CMP) Equal To (EQU) Greater than or Equal to (GEQ) Greater than (GRT) Less than or Equal to (LEQ)</p>	<p>Less than (LES) Limit Test (LIM) Mask Compare Equal to (MEQ) Not Equal to (NEQ)</p>
<p>Move</p> 	<p>Bit Distribute (BTD) Move (MOV) Masked Move (MVM)</p>	
<p>I/O Message</p> 	<p>Block Transfer Write (BTW) Block Transfer Read (BTR) Message (MSG)</p>	
<p>Program Control</p> 	<p>Jump (JMP) Label (LBL) Break (BRK) Subroutine (SBR) Return (RET) Master Control Reset (MCR) User Interrupt Disable (UID)</p>	<p>User Interrupt Enable (UIE) For Next Loop (FOR, NXT) Jump to Subroutine (JSR) End of Transition (EOT) Temporary End (TND) Always False (AFI) Sequential Function Chart Reset (SFR))</p>
<p>ASCII</p> 	<p>Test Buffer for Line (ABL) ASCII String to Integer (ACI) ASCII String Extract (AEX) ASCII Set or Reset Handshake Lines (AHL) ASCII String Concatenate (ACN) Number of Characters in Buffer (ACB) ASCII ReadCharacters (ARD)</p>	<p>ASCII Write (AWT) ASCII String Search (ASC) ASCII Integer to String (AIC) ASCII Write with Append (AWA) ASCII String Compare (ASR) ASCII Read Line (ARL)</p>
<p>PID</p> 	<p>Proportional, Integral, Derivative (PID)</p>	
<p>Diagnostic</p> 	<p>File Bit Comparison (FBC) Diagnostic Detest (DDT) Data Transitional (DTR)</p>	
<p>Specialty</p> 	<p>One Shot (ONS) One Shot Rising (OSR) Immediate Output (IOT)</p>	<p>One Shot Falling (OSF) Immediate Input (IIN)</p>

This broad range of instructions can save you time in developing programs by providing the instructions you need ready-made for your application.

*structured text***Programming Example**

```

IF (T4:0.DN) THEN
    TON (T4:0,0.01, 100, 0);
ELSE
    RES (T4:0);
END_IF;

IF (!(T4:0.DN) THEN
    TON (T4:0, 0.01,100, 0);
ELSEIF (T4:0.DN) THEN
    RES (T4:0);
END_IF;

```

Structured text resembles BASIC programming and you can use it to easily create, edit, and execute complex algorithms that involve variables representing a wide range of data types. Structured text works well in the following types of applications:

- data handling
- decision making
- computational sorting
- intensive mathematical

With Allen-Bradley's structured text option, you can use the PowerText™ monitoring tool to integrate real-time data table values with a structured text source program. See the example on the left.

Structured text supports the following constructs for PLC-5 processors:

Variable Assignment	:=	Assign an integer or a floating point value to a data table location.
Non-retentive Bit Assignment	:=	Make binary assignments to a storage bit. These bits are cleared to 0 when the processor mode changes from Program to Run or when the SFC step is postscanned.
Retentive Bit Assignment RETAIN		Make binary assignments to a storage bit. These bits are not cleared to 0 when the processor mode changes from Program to Run or when the SFC step is postscanned.
IF-ELSIF-ELSE		Conditionally execute a section of code.
FOR		Repeat a section of code a specified number of times.
WHILE		Repeat a section of code as long as an input expression is true.
REPEAT		Repeat a section of code until an expression becomes true.
EXIT		Exit an iterative construct (REPEAT, FOR, or WHILE) before the processor reaches the normal termination condition.
CASE		Conditionally execute a section of code based on the value of a math expression or operand.
::		Provided for IEC 1131-3 compatibility, similar to an NOP statement.
Ladder Functions		Call as a function almost any ladder instruction.

sequential function charts

You can use sequential function charts (SFCs) to control and display the state of a control process. Instead of one long ladder or structured text program for your application, divide the logic into manageable steps and transitions.

In this simple SFC, the logic for the mixer step is executed repeatedly until its transition is true. Then the processor executes the dump logic repeatedly until its transition is true.

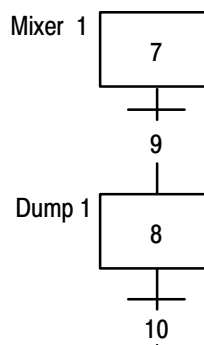

A step corresponds to a control task; a transition corresponds to a condition that must occur before the processor can perform the next control task. By displaying these steps and transitions, you can see the state of a machine process at any time.

Introducing PLC-5 Processors

*Powerful Program Control Features
main control programs*

You can use any mix of SFC, ladder, and structured text programs to define up to 16 main control programs (MCPs). Use several MCPs to define one main control program for each particular machine or function of your process.

For example, you can specify an SFC program to define the order of events in a process and a separate ladder logic or structured text program to directly control the outputs. Each of these can be an MCP. This lets you independently execute SFCs, ladder logic and structured text to structure your application into functional units and ease troubleshooting.

processor interrupt routines

You can specify both time- and event-driven interrupt routines for PLC-5 processors. Use selectable timed interrupts (STIs) when you want a portion of logic to execute at a specified time interval. For example, you can use an STI to monitor a machine's position every 250ms and calculate the average rate-of-change.

Use processor input interrupts (PIIs) when you want to execute a portion of logic immediately when an event occurs. For example, you can use a PII to eject a faulty bottle from a bottling line. A PII can detect an event within 100 microseconds and can act on successive events within 3 milliseconds.

PID algorithms

You can use Proportional Integral Derivative (PID) closed-loop control to hold a process at the set point you want. The PID instruction lets your processor monitor and control process loops for quantities such as pressure, temperature, flow rate, and fluid level. PID algorithms feature the following:

	<i>features</i>
output alarms	equations expressed in ISA or Independent Gains
output limiting with anti-reset windup	input and output transfer from 0-4095 (12-bit analog)
manual mode (with bumpless transfer)	input scaling in engineering units
feedforward or output biasing	zero-crossing deadband
displaying and monitoring PID values	derivative term (can act on PV or error)
	direct or reverse acting control

Password and Privilege System Protection

You can protect your programs using the processor's built-in passwords and privileges feature.

Set up to four privilege classes, each with access to different software operations. You can use passwords and privileges to protect:

- overall privilege classes
- channels
- stations/nodes
- individual programs and data files

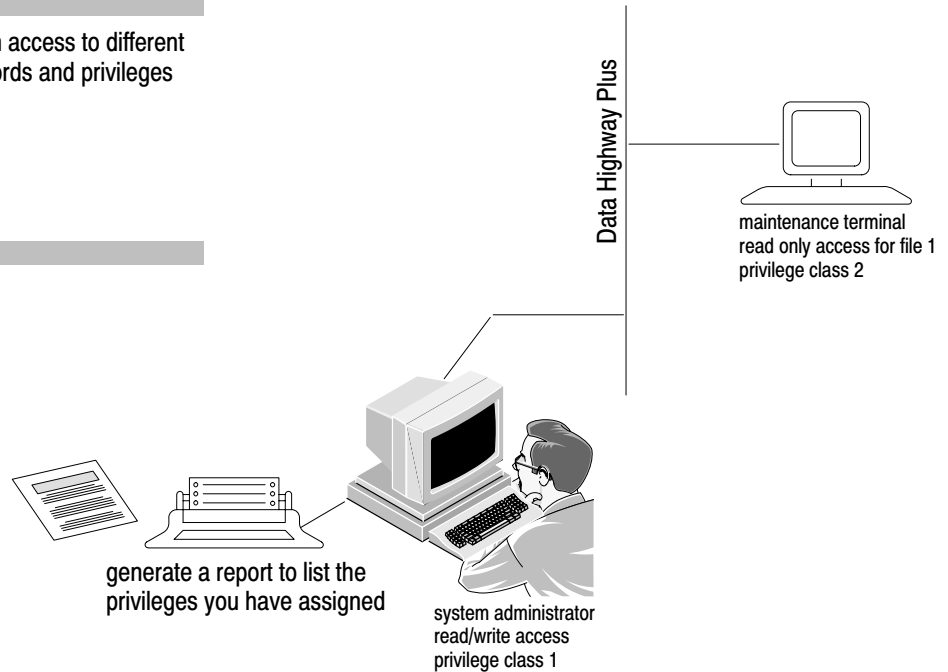

Advanced Math Functions

You can use a floating point data table file and the advanced math functions to perform complex calculations. Advanced math functions include logarithmic, trigonometric, statistical, exponential and square root functions.

Coprocessing Options

PLC-5 processors offer a built-in side connection that lets you connect directly to a control coprocessor module or Ethernet module. This connection also lets you access an Ethernet® network with the processor. See page 21 for more detailed information about coprocessor modules. See page 9 for more information about Ethernet options.

Introducing PLC-5 Processors

Built-in Serial Port

The serial port lets you interface with various modems to support Supervisory Control and Data Acquisition (SCADA) applications. For more information about SCADA applications, see page 24 or see the SCADA System Application Guide, publication AG-6.5.8.



PLC-5 processors offer a built-in serial port that you can configure for RS-232C, RS-423, or RS-422A communication. This serial port works directly with Allen-Bradley serial equipment so you don't need to buy anything extra.

You can use the processor's serial port to connect the processor to other Allen-Bradley and non-Allen-Bradley devices that:

- can send and receive ASCII characters
- communicate using DF1 protocol

The processor's serial port supports these configurations:

Keep in mind that when you configure channel 0 for RS-422A compatibility, you should not use terminating resistors anywhere on the link. When you configure channel 0 for RS-422A compatibility and RS-423, do not go beyond 200 feet regardless of baud rate.

RS-Port:	Maximum Cable Length:
232C	15 m (50 ft)
422A	61 m (200 ft)
423	61 m (200 ft)

Configurable Communication Port



PLC-5 processors offer built-in, configurable Data Highway Plus (DH+) or Remote I/O (RIO) ports. DH+ supports data transfer and remote programming for factory-floor applications in addition to peer-to-peer communications between other processors and devices. Remote I/O supports real-time data exchange for control of plant-floor devices.

With 6200 PLC-5 programming software, you can program PLC-5 processors over your DH+ network. This means that you can connect a single industrial terminal to your network and use it to program all the PLC® processors on your network. You can also use DH+ modules to implement a SCADA network. For more information about SCADA applications, see page 24 or see the SCADA System Application Guide, publication AG-6.5.8.

The remote I/O network connects chassis-based I/O and other compatible intelligent RIO devices to PLC-5 processors. Allen-Bradley designs its devices to be compatible with this link. Other vendors offer products that are also compatible with remote I/O network links. These products include robotic and welding controllers, scales, and wireless modems.

You can use the RIO link to speed communications and let the devices work together to improve quality while lowering integration, maintenance, and training costs.

I/O chassis and other devices on the link can be mounted up to 10,000 feet or 3,048 meters away from PLC processors. Or, for distributed processing, you can put a processor right at the I/O chassis where it can monitor its own resident I/O while communicating with a supervisory controller over the remote I/O link.

Ethernet Processors

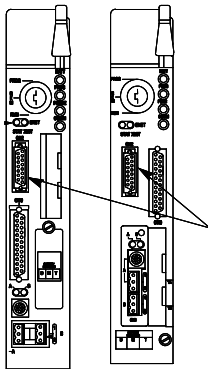

Dedicated Ethernet Port

PLC-5/20E processor
PLC-5/40E and -5/80E processor

Ethernet PLC-5/20E, -5/40E, and -5/80E processors offer embedded Ethernet TCP/IP communication capabilities; these processors provide the integration of Allen-Bradley architecture into an industry-standard Ethernet TCP/IP system, offering flexible, open-system solutions.

With the Ethernet processors' built-in communication capabilities, you have access to the entire Allen-Bradley control, communication, and information architecture. The Ethernet processors are optimized for real-time sequential and regulatory control and offer extensive application flexibility. See page 25 for more information about Ethernet solutions.

PLC-5 Ethernet Interface Module

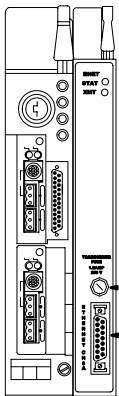

Enhanced PLC-5/40
1785-ENET interface module

The PLC-5 Ethernet Interface Module is a single-slot module that attaches to the side of any Enhanced PLC-5 Series B or later processor to provide Ethernet connectivity for the attached processor.

When used with	The interface module provides
Enhanced PLC-5 processor	Ethernet connectivity without sacrificing DH+/RIO ports
ControlNet PLC-5 processor	Ethernet connectivity
Ethernet PLC-5 processor	the ability to operate dual Ethernet links

Introducing PLC-5 Processors

Extended-local Processors

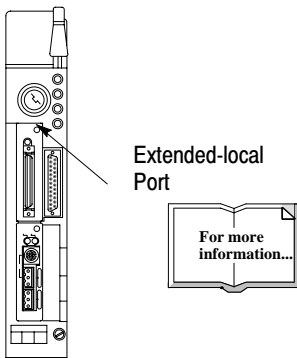

PLC-5/40L and
-5/60L processor

With PLC-5/40L and -5/60L processors and an extended-local I/O adapter module, you can use an extended-local I/O link to speed I/O updates. The extended-local I/O link is a parallel link that enables a PLC-5/40L or -5/60L processor to scan a maximum of 16 extended-local I/O chassis. Extended-local I/O chassis are updated in less than .5 milliseconds and can be connected up to 100 feet away from the chassis. For more information about PLC-5/40L and -5/60L processors, see the Enhanced PLC-5 Programmable Controllers User Manual, publication 1785-6.5.12.

VME Processors

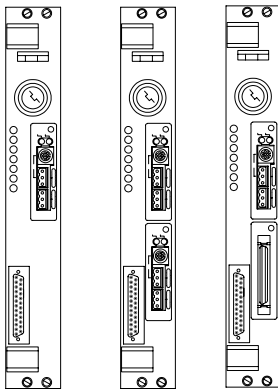

PLC-5/V30B processor PLC-5/V40B processor PLC-5/V40L processor

With PLC-5/VME VMEbus programmable controllers (PLC-5/VME processors), you can bring the technology of PLC-5 processors to the VMEbus environment. PLC-5/VME processors are functionally equivalent to other PLC-5 processors, but also:

- plug into a VMEbus system
- have a VMEbus communication interface designed for use with other VMEbus CPU modules
- can access VMEbus I/O modules

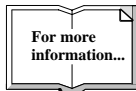

For more information about PLC-5/VME processors, see the PLC-5/VME User Manual, publication 1785-6.5.9.

Selecting a Processor

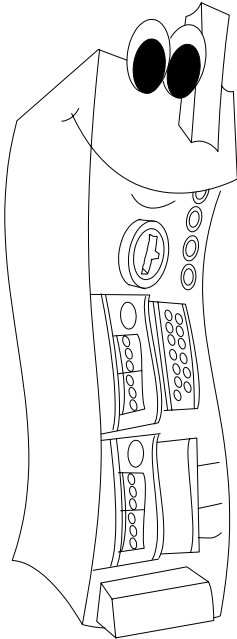

All PLC-5 processors share the common features described in the previous section, and some offer special communication options. Choose the right PLC-5 processor for your application by selecting the processor that meets the I/O, memory, and communication requirements to control your process. See the table below.

I/O Count:	Memory:	Communication ports:	Processor:
256 (any mix)	8K	1 DH+/Remote I/O	PLC-5/11
512 (any mix) 1024 (input +output)	16K	1 DH+, 1 DH+/Remote I/O	PLC-5/20
		1 DH+, 1 DH+/Remote I/O, 1 Ethernet	PLC-5/20E
1024 (any mix) 1024 (input +output)	32K	2 DH+/Remote I/O	PLC-5/30
2048 (any mix) 2048 (input +output)	48K	4 DH+/Remote I/O	PLC-5/40
		2 DH+/Remote I/O, 1 Local I/O	PLC-5/40L
		2 DH+/Remote I/O, 1 Ethernet	PLC-5/40E
3072 (any mix) 3072 (input +output)	64K	4 DH+/Remote I/O	PLC-5/60
		2 DH+/Remote I/O, 1 Local I/O	PLC-5/60L
3072 (any mix) 3072 (input +output)	100K	4 DH+/Remote I/O	PLC-5/80
		2 DH+/Remote I/O, 1 Ethernet	PLC-5/80E

example

REQUIREMENTS: You have 2,000 I/O points and need 50K of memory.
You also want Ethernet access.

- 1 Use the selection chart above to find which processors support your I/O count.

In this case, the PLC-5/40, -5/40L, -5/40E, -5/60, -5/60L, -5/80, and -5/80E processors all support your I/O count.

- 2 Use the chart to find which of those processors support your memory requirements.

In this case, only the PLC-5/60, -5/60L, -5/80, and -5/80E support both your I/O count and your memory requirement.

- 3 Use the chart to find which of those processors support your communication requirements.

In this case, you would select the PLC-5/80E, because only the PLC-5/80E supports Ethernet access, along with your I/O and memory requirements.

Input/Output Selections

Input/Output Selections

Allen-Bradley offers over 90 types of I/O modules and has 3 million modules installed in applications worldwide. 1771 series I/O is the industry's largest selection of I/O modules and addresses a broad range of manufacturing and process control applications.

We offer both rack- and block-based I/O selections.

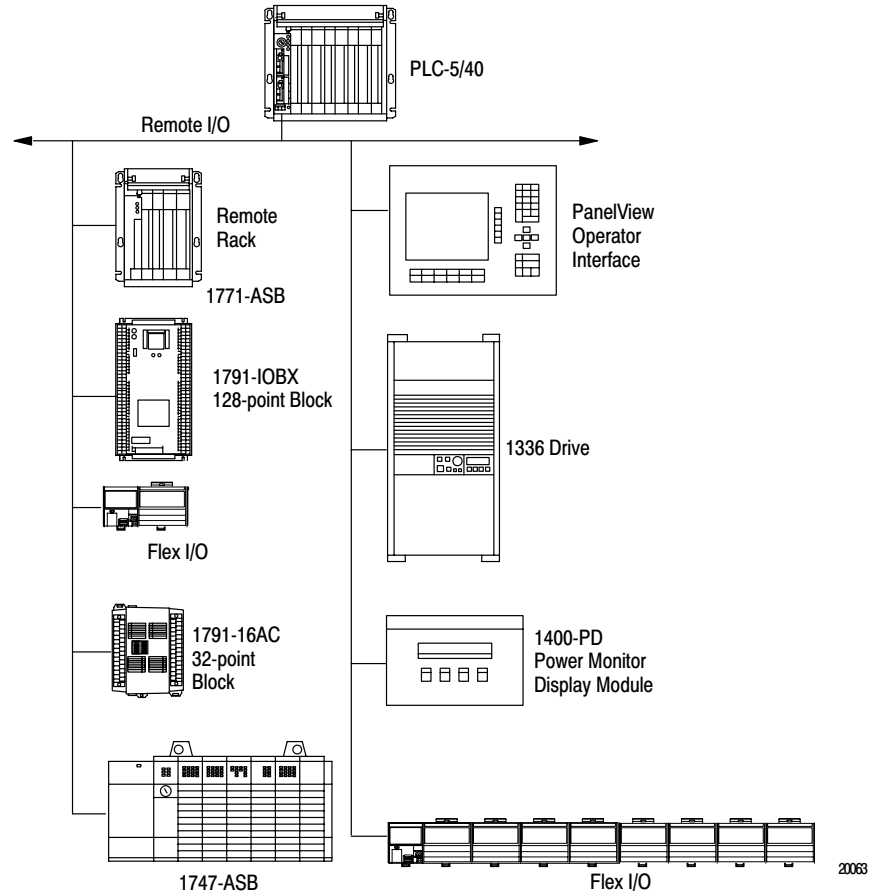

The following sections outline the available I/O selections. For more information about any of these selections, contact your Allen-Bradley representative. The following types of documents may assist you:

- product bulletins
- product catalogs
- reference guides
- product datas
- selection guides
- installation datas
- user manuals
- simplified schematics
- application notes

1771 series I/O offers over 90 modules to handle your discrete, analog, or special requirements.

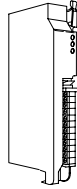
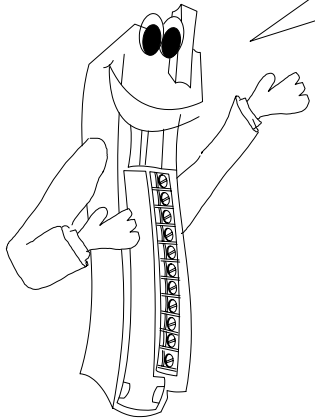

1771 modules feature:

- a broad range of signal interfaces to ac and dc sensors/actuators to fit your application
- modules available in different densities for up to 32 I/O for greater flexibility and cost savings
- wide range of signal levels including standard analog inputs and outputs and direct thermocouple and RTD temperature inputs

1794 series I/O (Flex I/O) is a flexible, low-cost, modular I/O system for distributed applications. Because flex I/O combines a terminal strip with an I/O interface, you can use the terminal strip on the terminal base to wire your field devices directly. Direct wiring saves you:

- installation and testing time
- additional wiring and external terminal blocks
- control panel space

Combining your field wiring terminations and the I/O interface into the same location saves you time and money and makes your system easier to maintain and troubleshoot.



1794 modules feature:

- modularity of design: reduces costs by solving a large range of application requirements with one I/O architecture
- small size: reduces packaging costs
- individual wire termination locations: reduces purchasing costs and complexity, as well as packaging costs
- diagnostics and removal and insertion under power capability: lowers the mean time to repair equipment and leverages your control investment
- flexible communications: helps to control future costs by providing an economical migration path

Allen-Bradley

Input/Output Selections

1746 series I/O is modular in its hardware design and offers a cost- and space-effective means to add I/O modules to your control system. I/O modules are available in 4-, 8-, 16-, and 32-point densities so that you can place many I/O modules in a single location.

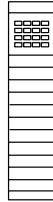

1746 modules feature:

- high-density 32-point and combination modules: reduces rack size and panel space requirements
- removable terminal blocks on 16-point modules: you can easily wire and replace modules
- industrial design: input filtering and optical isolation for exceptional reliability in industrial applications

1791 series block I/O puts its power in one small package so you can distribute your I/O more efficiently and install your system more cheaply than with comparable chassis-based I/O.

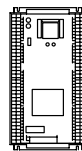

1791 modules feature:

- a self-contained package that provides cost-effective distribution of as few as 16 discrete I/O points to a remote location
- small size that lets you install blocks in a protected area of a machine or process
- you can panel or DIN-rail mount most 16- and 32-point ac, dc, and analog blocks in a vertical or horizontal operation

Selecting I/O

Select I/O to match the electrical requirements of your field devices. The following charts highlight the available modules.

1771 Standard Analog I/O Modules (12-bit resolution)

Type	Number of Inputs/Outputs	Channel Update/Resolution	Voltage Range	Current Range	Data Format
High-Res TC/mV Input	8 floating differential	25ms/8 channels 15 bits+sign (0.1 °C/0.1° F/bit)	Type B, E, J, K, R, S, T ±99.99mV	N/A	Binary only
RTD Input	6 RTD inputs (three wire)	50ms/8 channels 16 bit resolution (0.1 °C/0.1° F/bit)	100Ω platinum 10Ω copper or other	N/A	Binary or BCD Actual temperature or Ohm readings
Analog Output	4 isolated outputs (1000 V)	8.0ms/4 chnls (BCD) 1.6ms/4 chnls (Binary) 12-bit res + sign	1-5V dc 0-10V dc ±10V dc	4-20 mA 0-50 mA	Binary or BCD Scaled to ±9999

1771 High Resolution Analog I/O Modules (16-bit resolution)

Input	Type	Number of Inputs	Output Types	Type	Number of Outputs
Current	4-20mA	0, 2, 4, 6, 8	Current	0-25mA, 0-50mA	0, 2, 8
MV/TC	B, R, S,E, J, K, T		Voltage	± 10V dc	
RTD	Platinum, Nickel, Copper				
Voltage	± 10V dc, ± 5Vdc				

Build-to-Order Program: We will quote you a custom configuration when you tell us your type and number of input and output requirements. Contact your Allen-Bradley representative for details.

1771 Discrete Output Modules

Number of Modules	Type	Voltage Category	Number of Outputs	Current Per Output	Applications
2	ac	24	8, 16	1.5A, 2.0A	<ul style="list-style-type: none"> ■ Relay coil driver ■ Low voltage inductive loads
7		120	4, 6, 8, 16		
3		220	6, 8, 16	2.0A	<ul style="list-style-type: none"> ■ General purpose
1		120/220	32	0.3A	
2	dc	5 TTL	8, 16	0.2A sinking 0.001A sourcing	<ul style="list-style-type: none"> ■ TTL interfaces
6		10-60	8, 16, 32	.5A, 1A, 1.5A, 2A	<ul style="list-style-type: none"> ■ -V dc output signal termination ■ Isolated circuits ■ electronic fusing/current limiting
2		10-32	16-32	0.5A, 2A	<ul style="list-style-type: none"> ■ isolated circuits ■ general purpose ■ +V dc output signal termination

Allen-Bradley

Selecting I/O

1771 Process Control I/O Modules

Module	Number of Inputs/ Outputs	External Power Required	Channel Update/ Resolution	Voltage Range	Current Range	Data Format
PID Control Module	2 PV inputs 2 tieback inputs 2 outputs	±15V dc	100ms (Loop) 12 bit resolution	1-5V dc	4-20 mA	Scaled BCD ±9999

1771 Discrete Output Relay Modules

Number of Modules	Operating Voltage	Number of Outputs	Current Per Output	Contacts	Applications
4	24-138 V ac 24-125 Vdc (30 watts max)	8, 16, 32	0.25A-2A	8 selectable-32 selectable	<ul style="list-style-type: none"> ■ mixed voltages ■ no leakage current ■ isolated
1	0-250 ac 0-175 dc	4 isolated	2A @ 200V ac	4 selectable	<ul style="list-style-type: none"> ■ signal switching ■ isolated circuits
2	0-24 ac/dc	8 (4 groups of 2)	0.1A	4 N.O., 4 N.C., 8 N.O.	<ul style="list-style-type: none"> ■ physical isolation ■ low power dissipation ■ no leakage current

1771 Discrete Input Modules

Number of Modules	Type	Sinking or Sourcing	Voltage Current	Number of Inputs	Applications
2	ac/dc	n/a	24	8, 16	<ul style="list-style-type: none"> ■ General-purpose ■ General-purpose ■ Isolated-circuit multi-phase applications
5			120	6, 8, 16, 32	
3			220	6, 8, 16	
2	dc	TTL	5	8,16	<ul style="list-style-type: none"> ■ General-purpose
7	dc	sinking	10-60	8,16, 32	<ul style="list-style-type: none"> ■ General-purpose
2		sourcing	10-30	8, 32	
		sinking, sourcing	5-32	8, 16	

1771 Specialty I/O Modules

1771 Communication I/O Modules

- FiberOptic Converters
- Local I/O Adapters
- Remote I/O Adapters
- I/O Scanners

1771 Specialized Modules

- Configurable Flowmeter Module
- High-speed Logic Controller
- Latching Input Module
- Wire Fault Module
- Multiplexer input Module
- Clutch/Brake Control System
- Simulator I/O Module
- Vision Input Module
- Power System Line Synchronization Module

1771 Positioning Modules

- Stepper Positioning Modules
- Servo Positioning Modules with and without
Contouring
- Absolute Encoder Modules
- Gray Code Encoder Modules
- Injection Control Modules
- Force Control Modules
- High-speed Control Modules

1771 Peripheral Interface Modules

- ASCII and BASIC module
- RS-232/422/423 Modules

1791 Analog I/O Blocks

Number of Blocks	I/O Block Power Source	Inputs			Outputs		
		Number of Inputs	Resolution	Ranges	Number of Outputs	Resolution	Ranges
2	85-120V ac	4	14 bits	± 10V; ± 5V 0-10V; 0-5V 0-20 mA (block supplies loop power)	2	13, 14 bits	± 10V, 0-20 mA
	19.2-30V dc						

1791 Discrete I/O Blocks

Number of Blocks	I/O Block Power Source	Inputs		Outputs			
		Type	Number of Inputs	Type	Number of Outputs	Max Current Per Output (All outputs on unless otherwise noted)	
9	19.2-30V dc	10-30V dc sinking	0, 8,16,24, 32	10-30V dc sourcing	0, 8,16, 32	500 mA at 60 °C-1A at 30 °C	
	85-120V ac	79-132V ac		contact		20-132V ac	300 mA at 60 °C-600 mA at 30 °C
				contact			
4	18-26.4V dc	18-26.4V dc sourcing	32, 64	18-26.4V dc sinking	32, 64	300 mA at 60 °C	
		18-26.4V dc sinking		18-26.4V dc sourcing			

1746 Discrete Input Modules

Number of Modules	Type	Voltage Category	Number of Inputs	Applications
3	AC	85-132V	4, 8, 16	General-purpose 120V ac inputs
		170-265V		General-purpose 220/240V ac inputs
1	DC	5V sourcing	16	TTL input, BCD inputs
3		10-30V sourcing	8, 16	General-purpose dc inputs; fast response for time-critical applications
1		24V sourcing	32	General-purpose dc inputs; high-density for limited panel space
2		10-30V sinking	8, 16	General-purpose dc inputs; fast response for time-critical applications
1		24V sinking	32	General-purpose dc inputs; high-density for limited panel space
1	AC/DC	24V	16	V ac or V dc operation

1746 Discrete I/O Combination Modules

Number of Modules	Voltage Types	Number of Inputs	Output Voltage Types	Number of Outputs	Applications
3	85-132V ac	2, 4, 6	5-265V ac	2, 4, 6	Combination 120V ac inputs and relay contact outputs
			5-125V dc		
			relay contact		

1746 Discrete Output Modules

Number of Modules	Types	Voltage Category	Number of Outputs	Current Rating @ 60 °C	Applications
2	AC	85-265V	8, 16	.25A - .5A	General-purpose 120/240V ac outputs
4	DC	5-50V sourcing		.5A - 1A	General-purpose dc outputs
5		5-50V sinking	8-32	.25A - 1A	TTL loads; sourcing BCD devices
4	relay contact	5-265V ac	4, 8, 16		individual isolation
		5-125V dc			4outputs/common 8outputs/common

Allen-Bradley

Selecting I/O

1746 Analog I/O Modules

Type	Number of Inputs	Input Voltage Range	Number of Outputs	Output Voltage Range	Channel Update/Resolution
analog input	4	±10V dc ±20ma			60ms @95% step res. 16 bit resolution
analog output			4	0-20ma ±10V dc	2.5ms @95% step res. 14 bit resolution
analog combination	2	±10V dc ±20ma 0-20ma	2		60ms @95% step res. output 2.5ms 16 bit resolution
thermocouple/mv	4	J, K, T E, R,S ±50mv ±100mv			12ms @ 100% step res. .1° C, .1° F 0.01mV

1746 Specialty I/O Modules

1746 Communication I/O Modules

SLC 500⇒DH485 Interface
Direct Communication Module
Remote I/O Scanner
Remote I/O Adapter

1746 Peripheral Interface Modules

Basic Module
RS-232⇒DH485 (DF1 protocol)
RS-422
RS485

1746 Positioning Modules

Single Axis Servo Controller Module
High-speed Counter Coder Module

1794 Flex I/O System Components

Communication Adapters	Terminal Bases	Discrete and Analog I/O Modules		
		Type	Voltage	Number of Points
RIO	2 wire or 3 wire	DC, sinking, input	24V dc	16
		DC, sourcing, output		
		Sensor input		
		AC input	120 V ac	8
		AC output		
		Analog input	0-10 ±10	8
		Analog output	4-20mA 0-20mA	4

Selecting a Chassis

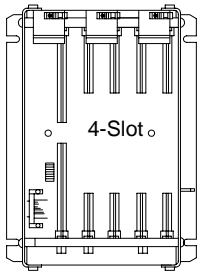

If you use 1771 or 1746 I/O modules, you will need to select a chassis when you specify your system. You should consider the following when you select a chassis:

When you determine the maximum number of I/O in your application, leave space for the I/O slots dedicated to power-supply modules, communication modules, other intelligent I/O modules, and expansion.

I/O chassis are available in four sizes:

For 1771 Modules:

- 4-slot
- 8-slot
- 12-slot
- 16-slot

For 1746 Modules:

- 4-slot
- 7-slot
- 10-slot
- 13-slot

For 1771 I/O modules, you can also choose a chassis with an integral power supply and remote I/O adapter. The two types are:

- 1-slot
- 2-slot

For 1746 I/O modules, you can also choose an optional 2-slot expansion chassis that provides up to 64 additional points of I/O or an interface to specialty I/O modules.

Selecting a Chassis and Power Supply

Selecting a Power Supply

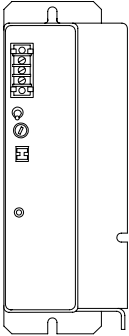

You will also need to select a power supply when you specify your system. When you're ready to select a power supply, these are guidelines you should follow:

1. Determine the input voltage for the power supply.
2. Calculate the total backplane current draw for I/O modules by adding together the backplane current draw for each I/O module in that chassis.
3. Add to the total of the I/O module backplane current draw either:
 - a. 3.3 Amps when the chassis will contain a PLC-5 processor **or**
 - b. 1.2 Amps when the chassis will contain either a remote I/O 1771-AS or -ASB module or a 1771-ALX extended-local I/O adapter module
4. If you leave slots available in your chassis for future expansion:
 - a. list backplane current draw for future I/O modules
 - b. add the total current draw for all expansion I/O modules to the total calculated in step 3
5. Determine whether the available space for the power supply is in the chassis or mounted external to the chassis.

Choose your power supply using the input voltage requirement and the total backplane current draw you just determined.

For 1771 I/O modules, Allen-Bradley offers a wide range of power supplies with input voltages from 120V ac to 220V ac or 240V dc that supply 8 to 24 amps in various configurations. We also supply redundant power supplies for added security. For more information, see your Allen-Bradley representative.



For 1746 I/O modules, Allen-Bradley offers three different power supplies, two ac and one 24V dc. You can configure the ac supplies to operate using 120 or 240V ac. For more information, see your Allen-Bradley representative.

Processor Options

In addition to the base processors, PLC-5 processors offer many options. This section describes these options.

EEPROM Module Memory

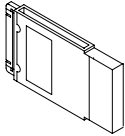

You can back up memory by using EEPROM modules that give you alternative storage for your program files. Four sizes are available: 16, 32, 64, and 100K words.

Expand System Fault Tolerance

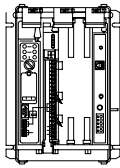

You can expand system fault tolerance by using a backup communication module. Backup communication modules provide high-speed communication and switchover to a secondary processor system when a fault or power failure occurs in the primary PLC-5 system.

Backup communication modules back up two DH+/RIO ports. Backup expander modules are available to back up an additional two DH+/RIO ports, or four DH+/RIO ports total.

Coprocessor Programming Flexibility

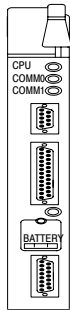

With a control coprocessor, you can expand the capability of your PLC-5 system to run programs in C, BASIC, and assembler languages in a real-time, multitasking operating system environment. These programs run independently of PLC-5 control logic but have access to PLC-5 memory.

The control coprocessor performs a wide range of functions including:

- complex math or application-specific algorithms
- alternate control programming with third-party (PSP) programming packages such as *fuzzyTech*'s[®] fuzzy logic or Event Technology's function block programming with GELLO[®]
- memory-intensive production scheduling or data logging/trending
- high-speed search and compare of very large files or look-up tables
- protocol conversion for interfacing a PLC processor with a variety of field devices

The industrially-hardened module fits in a 1771 chassis and offers direct and standard I/O communication with PLC-5 processors. With an optional expander module, you gain two additional serial communication ports, a keyswitch for reinitializing the control coprocessor without cycling power, and a 4-digit alphanumeric display for diagnostic reporting.

Integrating the System

Integrating the System

Rockwell Software Inc. (RSI) offers numerous products to ease the integration of your PLC-5 system into new or existing architectures. These products include the following.

RSView Man/Machine Interface Software

RSView32™ leverages open technologies within the Microsoft Windows NT™ and Windows 95® platforms such as ODBC, OLE, and DDE. It provides leading edge productivity enhancing tools by allowing changes while online with field equipment. For example, RSView32 allows runtime changes to graphic displays, tag addresses, node addresses, as well as PLC network and device driver configuration adjustments. RSView32's graphics offer the flexibility of integrating ActiveX controls and OLE objects such as Microsoft Excel spreadsheets or Microsoft Word documents along with its own powerful graphical editing tools and libraries. RSView32 takes advantage of the Microsoft Windows NT multitasking environment with its full featured Multi-Model Data Logger, Trending, Alarming and Event triggering components to help you define your monitoring and supervisory control needs.

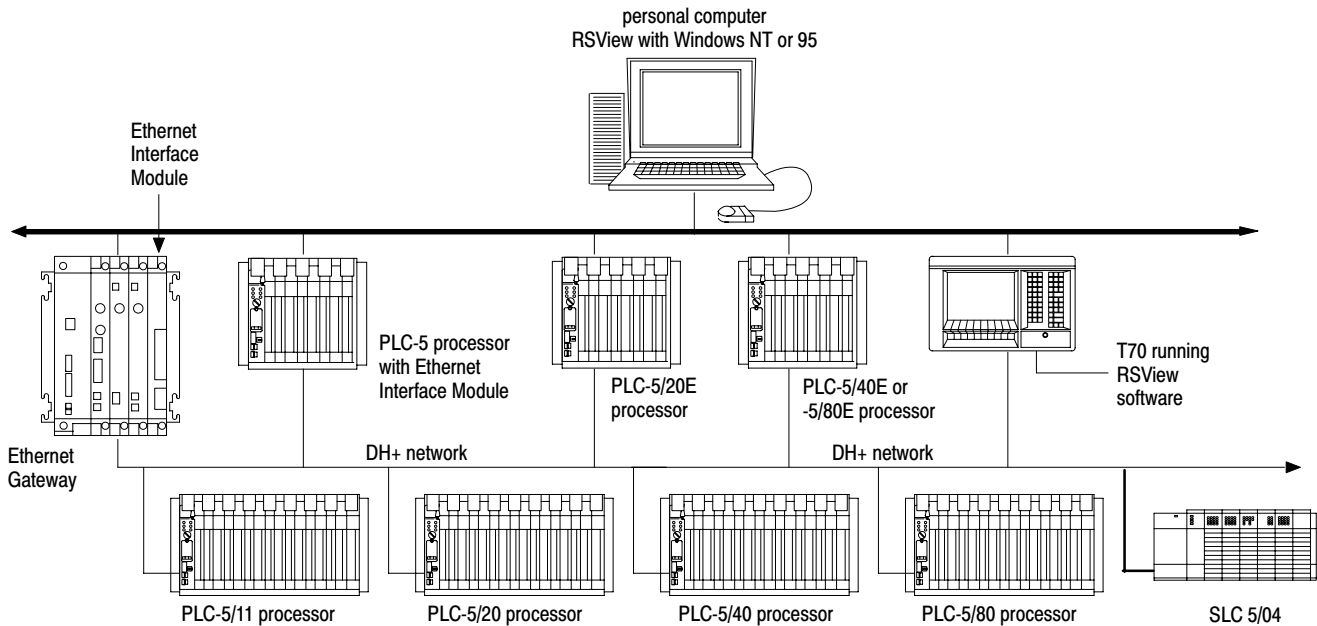

INTERCHANGE Software on an Ethernet Network

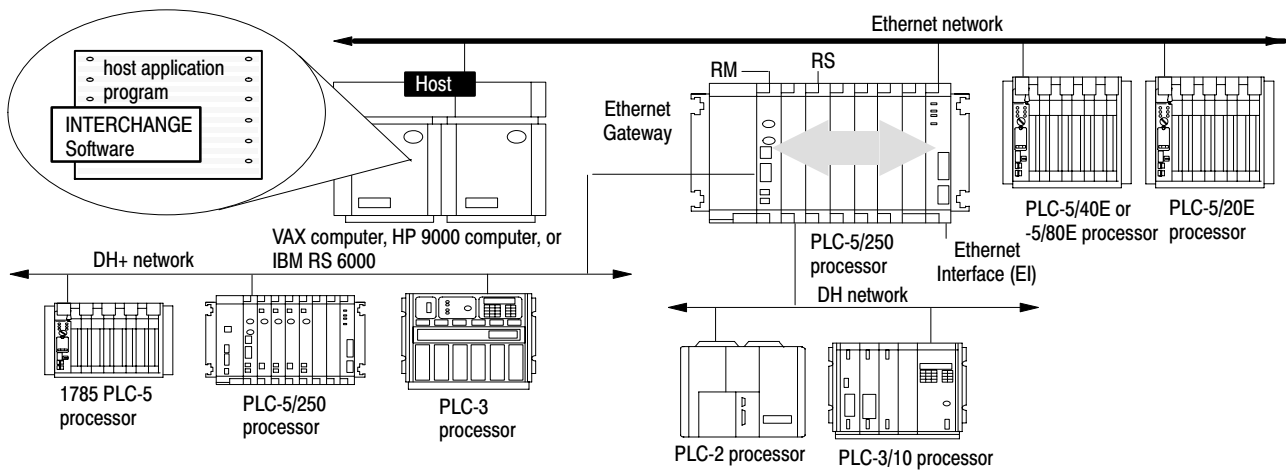

INTERCHANGE™ software is an Application Programming Interface (API) that simplifies communication between a variety of host computer operating systems and Allen-Bradley processors. You can use INTERCHANGE software when you need to share data between plant floor and manufacturing systems.

With INTERCHANGE software on a host computer, you can interface directly with PLC-5 processors over DH, DH+ and Ethernet links. You do this by including INTERCHANGE software function calls in your C application programs.

In addition, with the INTERCHANGE software Dynamic Data Exchange (DDE) option, you can directly access data in PLC-5 processors to accomplish process-to-process communication. The DDE option complies fully with the Dynamic Data Exchange Management Library, the set of function calls defined by Microsoft for DDE communication, and is compatible with both the KT and Ethernet versions of INTERCHANGE software.

Allen-Bradley

Open Architecture

Open Architecture

Allen-Bradley offers many control and communication media products that help you to integrate various plant operations. These products work with other vendors' products to provide the plant-wide solutions that meet your control system and business needs. These products include SCADA, Ethernet, ControlNet, and DeviceNet.

Use Allen-Bradley SCADA Systems in a Variety of Applications

SCADA is an acronym for Supervisory Control and Data Acquisition. SCADA systems let you monitor and control various remote functions and processes using serial communication links between master and remote locations.

You can use SCADA in a variety of applications; for example, you could:

- monitor and record the physical properties of the oil flowing through a pipeline in the Alaskan tundra, using only a few remote points
 - automatically retrieve or store parts within a factory using radio or power-line modems
 - monitor and pump the water supply for a city or small town
 - monitor and control offshore oil- or gas-pumping platforms from the land-based refinery.
- Integrate the data you gather into the overall process for producing and shipping the final product.

SCADA Systems

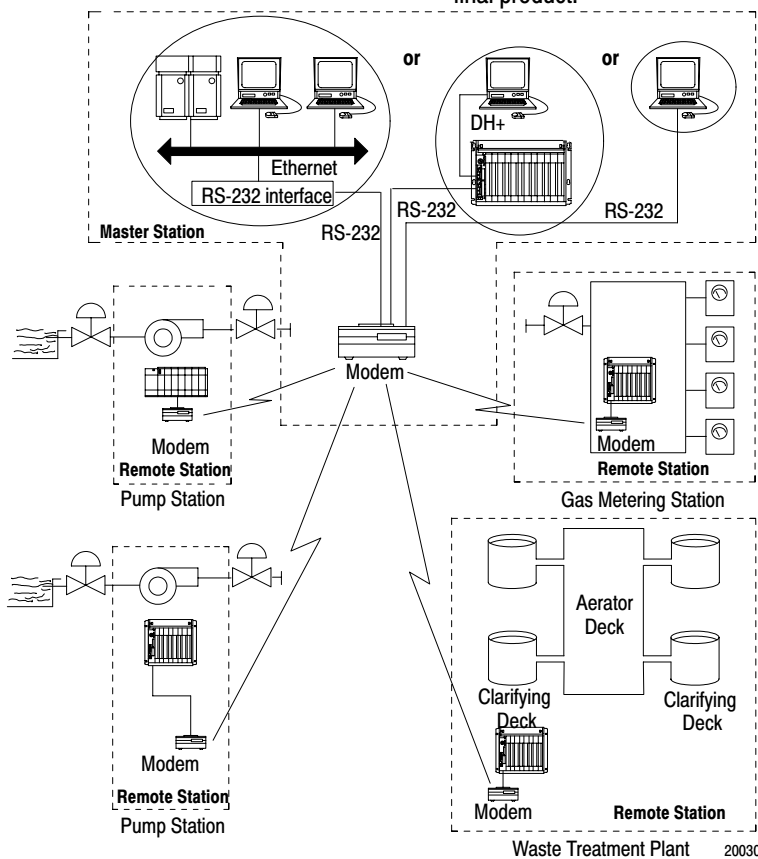

Allen-Bradley SCADA Systems are Flexible

You can use Allen-Bradley master and remote stations with products supplied by other vendors to communicate with other protocols, such as:

- Modbus™
- Teledyne-Brown Control Applications (CA)

You can also use data communication equipment supplied by other vendors with Allen-Bradley SCADA system components to connect to a variety of communication media, such as:

- telephone
- radio
- power lines

And when you use PLC-5 processors in your SCADA application, you can choose from six available processor memory sizes to fill your master or remote station requirements. PLC-5 processors provide built-in support for serial communication links as well as Ethernet connectivity that uses standard TCP/IP protocol, when you need it. For more information about SCADA system solutions, see publication AG-6.5.8.



Ethernet Network

A Wide Open Network

Ethernet is a local area network with a baseband communication rate of 10M bit/s designed for the high-speed exchange of information between computers and related devices. Allen-Bradley takes a systemic approach to the introduction of products having Ethernet TCP/IP connectivity so that all have the necessary features and functions to interoperate and all can be managed as a uniform network.

The figure shows an Ethernet system where an HP 9000™, VAX® computer, or personal computer (PC) interfaces with Allen-Bradley PLC-5 processors, sharing and passing information. Using Ethernet, all facets of your operation can communicate with each other.

The Possibilities are Almost Limitless

With an Ethernet network, you have near-limitless networking possibilities because you can maximize communication between the great variety of equipment available from many vendors. Ethernet also provides easy access to printers and file servers so you can access devices previously “out of your reach” and share expensive resources. For more information about Ethernet system solutions, see Integrating Allen-Bradley Products on an Ethernet TCP/IP Network, publication 1785-2.31.

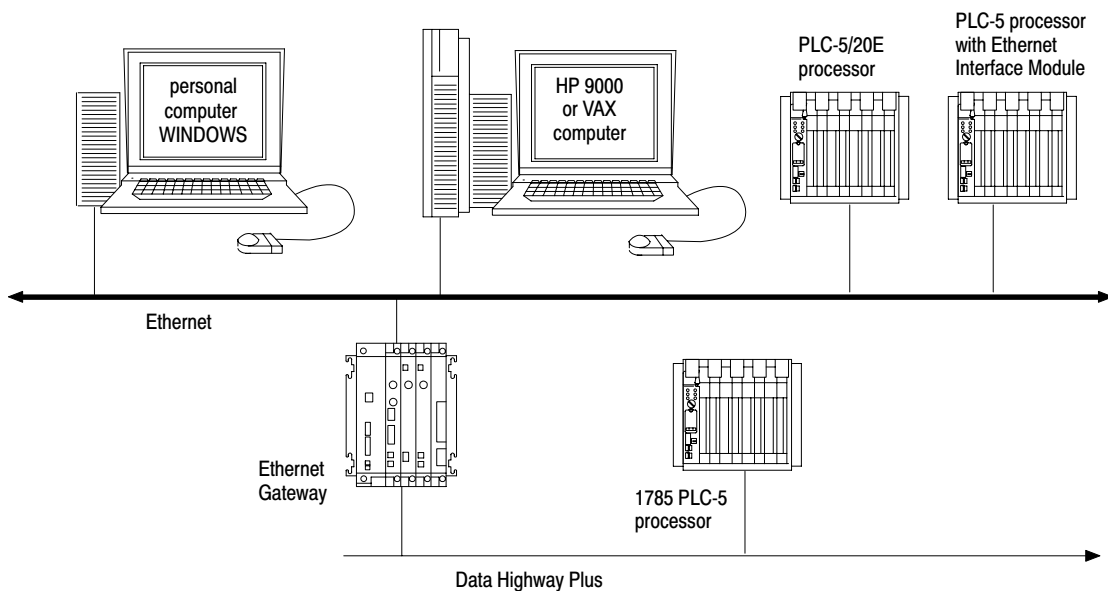
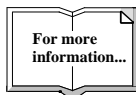

Allen-Bradley

Open Architecture

ControlNet

The ControlNet network is a high-speed deterministic network used for the transmission of time-critical application information. Used within the Allen-Bradley architecture, it provides realtime control and messaging services for peer-to-peer communication. As a high-speed link between programmable controller and I/O devices, it combines the capabilities of existing Remote I/O and Data Highway Plus links. A variety of devices can be connected to a ControlNet network, including personal computers, programmable controllers, operator interfaces, and other devices with ControlNet connections.

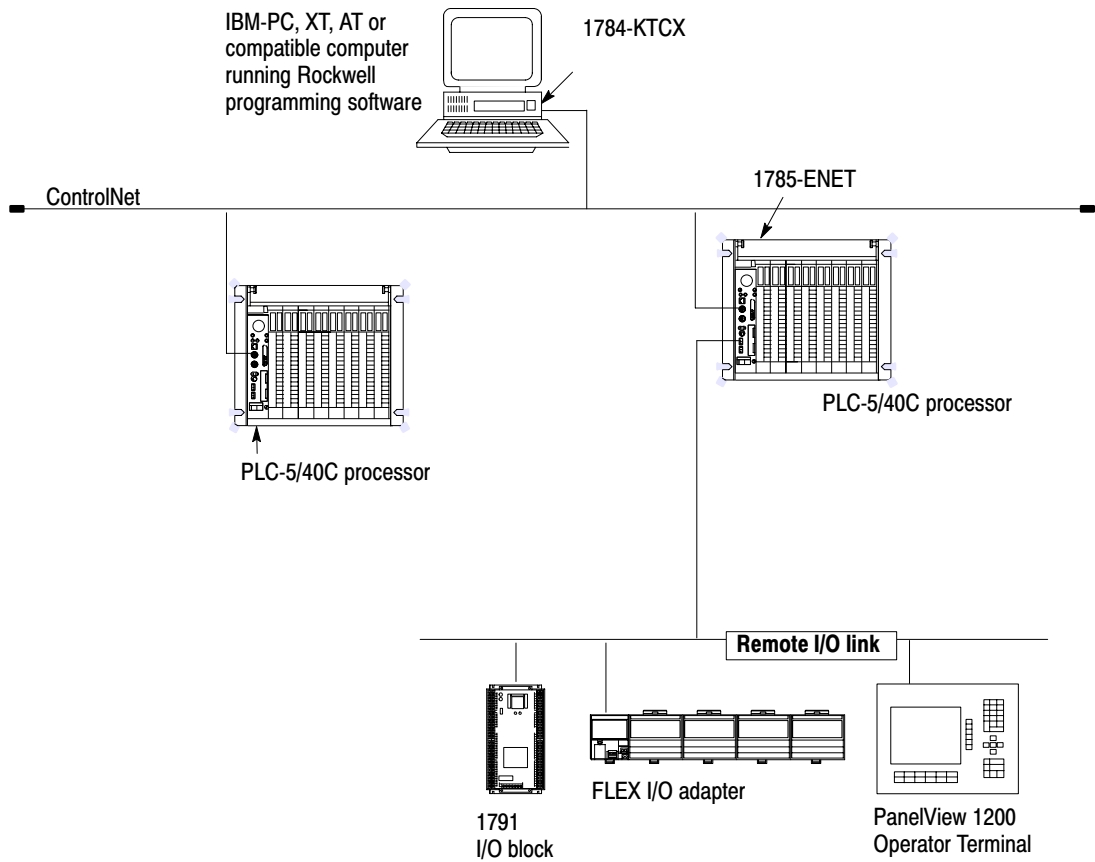

DeviceNet

An Open Device Network Standard

DeviceNet is an open, low-level communication link that provides connections between simple industrial devices (sensors, actuators) and higher-level devices (processors). This open network offers a level of interoperability between like devices from multiple vendors.

Flexible, Compatible Communication Between Simple Devices

DeviceNet also accommodates devices with vendor-specific, value-add options. DeviceNet provides:

- **interoperability:** simple devices from multiple vendors that meet DeviceNet standards are interchangeable, giving you flexibility and choice
- **a common network:** an open network provides common, end-user solutions, and reduces the need to support a wide variety of device networks
- **insurance of a proven standard:** Because DeviceNet is based on the proven Controller Area Network (CAN) technology industry-wide understanding and acceptance grows
- **assistance in decreasing maintenance costs:** you can remove and replace devices without disrupting other devices on the network
- **cost effective wiring:** networked device installation is more cost-effective than traditional I/O wiring in many applications

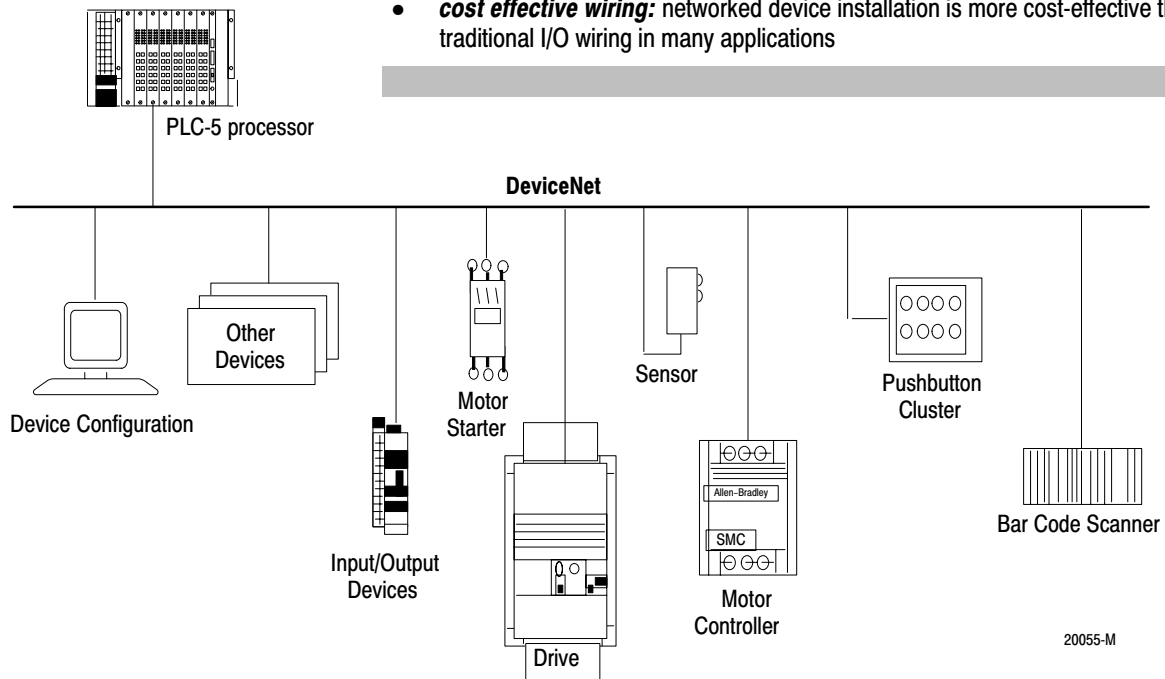

Allen-Bradley

Using the Software

PLC-5 A.I. Series Programming Software

Rockwell Software's PLC-5 A.I. Series is an easy-to-use, menu and function-key driven software package for programming the Allen-Bradley PLC-5 family of processors. Rockwell Software's features enable the beginner to quickly become proficient in ladder logic development and documentation. The advanced user will find Rockwell Software's powerful editing and diagnostic tools to be great time savers during ladder program development and troubleshooting.

Online and Offline modules offer complete programming, documentation, and reporting, as well as upload/download capabilities. The help system assists the user with unique features of the software, as well as specific information on the PLC's instruction set. For more information on specific features, please see the overview of the complete A.I. Series.

Rockwell Software also offers an A.I. Series Processor Emulation Module. Processor Emulation provides a convenient means for testing and debugging ladder logic offline on your computer. Using emulation, you can troubleshoot your program one scan at a time and add breakpoints to trap unexpected conditions. See A.I. Series Processor Emulation for further information.

A.I. Series Features

- **cross-referencing:** displays cross-reference information from the data table
- **reporting:** offline and online data table usage reports
- **memory:** extended memory support
- **partial download:** select specific program or data table files to be downloaded instead of a complete ladder program
- **sequencer display:** screens and reports
- **configurable screen size:** for custom data display
- **programming:** SFC and Structured Text
- **program compare:** ladder and data table programs
- **diagnostics:** DH/DH+ and DH-485
- **keyboard macros**
- **security**
- **DOS file utilities**

Allen-Bradley Support

In today's competitive world, when you buy a product, you expect that product to meet your needs. You also expect the manufacturer of that product to back it up with the kind of customer service and product support that prove you made a wise purchase.

As the people who design, engineer, and manufacture your industrial automation equipment, we at Allen-Bradley have a vested interest in your complete satisfaction with our product and services.

We offer worldwide support services, with over 75 sales and support offices, 512 authorized distributors, and 260 authorized systems integrators located throughout the United States alone, plus Allen-Bradley representatives in every major country in the world.

We're global because we're local where you are.

In addition, Allen-Bradley supports its software with phone support, warranties, and support extension programs. Remote Software Support (RSS) is available for the DOS platform version of 6200 software. With RSS, the Allen-Bradley System Support Center can connect to your computer via modem to help troubleshoot your system.

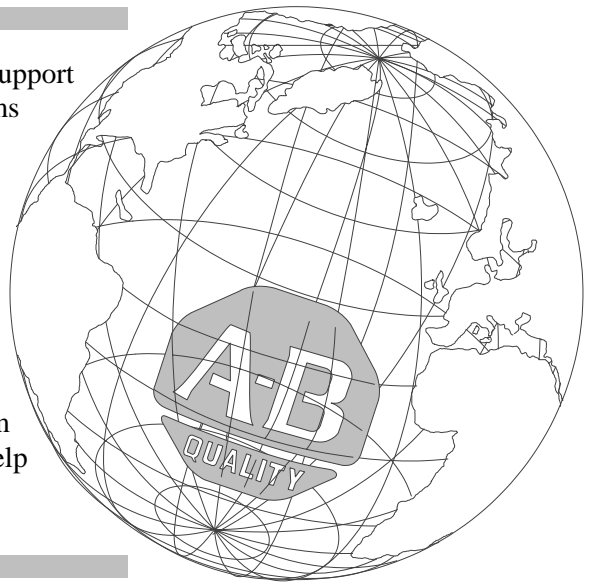

Call your Allen-Bradley representative for:



- sales and order support
- technical product training
- warranty support
- support service agreements

Allen-Bradley

For More Information ...

For More Information ...

If you want more detailed information, your Allen-Bradley representative is always available to take your call. In addition, the following publications are available as part of the PLC-5 documentation library.

Publication #	Title
1785-10.4	Enhanced PLC-5 Programmable Controller Quick Start
1785-10.5	Ethernet PLC-5 Programmable Controller Quick Start
1785-6.5.12	Enhanced and Ethernet PLC-5 Programmable Controllers User Manual
1785-6.1	PLC-5 Programmable Controllers Instruction Set Reference
1785-7.1	PLC-5 Programmable Controllers Quick Reference
1785-2.35	Classic PLC-5 Programmable Controller Product Data
1785-6.6.1	Classic PLC-5 Family Programmable Controller Hardware Installation Manual
1785-6.2.1	Classic PLC-5 Programmable Controllers User Manual

What to Do Next



We suggest that you call your Allen-Bradley representative after working through the guidelines that follow in the back of this book. Your representative can answer your questions, provide more information, and help you to specify a PLC-5 system that suits your unique needs.

PLC and PLC-5 are registered trademarks of Allen-Bradley Company, Inc.
ControlView, Data Highway Plus, DH+, INTERCHANGE, PanelView, PowerText, PLC-5/11, PLC-5/15, PLC-5/20, PLC-5/20E, PLC-5/25, PLC-5/30, PLC-5/40, PLC-5/40E, PLC-5/40L, PLC/60, PLC-5/60L, PLC-5/80, and PLC-5/80E are trademarks of Allen-Bradley Company, Inc.

Ethernet is a registered trademark of Digital Equipment Corporation, Intel and Xerox Corporation.
Fuzzy logic is a registered trademark of *fuzzyTech*, Inc.
GELLO is a registered trademark of Event Technology, Inc.
DEC, DECnet, MicroVAX, and VAX are registered trademarks of Digital Equipment Corporation.
Hewlett-Packard is a registered trademark of Hewlett-Packard Company.
HP 9000 and HP-UX are trademarks of Hewlett-Packard Company.
i386, i486, and Intel are trademarks of Intel Corporation.
IBM and PC-DOS are registered trademarks of International Business Machines Corporation.
Modbus is a trademark of Modicon, Inc.
MS-DOS, Windows95, and WindowsNT are registered trademarks of Microsoft.
Novell is a registered trademarks of Novell, Inc.
PC/TCP is a registered trademarks of FTP Software, Inc.

Allen-Bradley

Preparing to Layout a PLC-5 System

Use these guidelines to understand your requirements and to begin to lay out your PLC-5 system. When you finish, please call your Allen-Bradley representative with any questions or for specific ordering and pricing information.

When you select:

a processor



you should consider:

- I/O requirements
How much I/O do you need to control your process?
Record this information.
- memory requirements
How much memory do you need to control your process?
Record this information.
- communication requirements
What type of communication access do you need in your process?
Record this information.

I/O

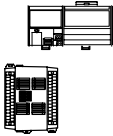

the electrical requirements of your field devices

- 1771 I/O offers a breadth of choices and has the largest installed base
- 1791 I/O offers the lowest-priced distributed I/O in one small package
- 1746 I/O offers many interface options and is cost-effective due to its modular hardware design
- 1794 I/O offers the lowest installed cost due to reduced wiring needs

an I/O chassis

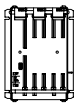

- the type of I/O you're using
If you're using 1771 or 1746 I/O modules, you need to select a chassis. Four sizes are available.
- I/O slots dedicated to power supply modules, communication modules, or other intelligent I/O modules
Allow space in the chassis for these modules.
- integral power supply and remote I/O adapter
If you want these options, two types are available.

a power supply

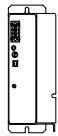

- input voltage for power supply
- total backplane current draw for I/O modules
- what the chassis will contain
You will need to add 3.3 Amps to the total backplane current draw if the chassis will contain a PLC-5 processor; add 1.2 Amps if the chassis will contain either a remote I/O 1771-AS or -ASB module or a 1771-ALX extended-local I/O adapter module.
- backplane current draw for future I/O modules
If you leave room in your chassis for future expansion, you must consider the backplane current draw for those modules.
You will need to add the total current draw for expansion modules to the previous total.
- available space for the power supply
You will need to determine whether the available space for the chassis is in the chassis or mounted external to the chassis.
Record your input voltage requirements and the total backplane current draw to select a power supply.

When you select:

processor options

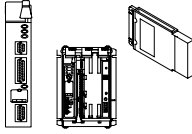
**you should consider:**

- how to back up processor memory
 - If you want to back up processor memory right at the processor, consider an EEPROM module memory card.
- what you want to happen when a fault or power failure occurs
 - If you want to switch to a secondary processor if this happens, consider a backup communication module.
- programming in C, BASIC, or Assembler languages
 - If you want to program in these languages, consider a control coprocessor module.
- how to easily perform:
 - complex math or application-specific algorithms
 - alternate control programming (fuzzy logic or GELLO)
 - memory-intensive production scheduling
 - datalogging/trending
 - high-speed search and compare of very large files or look-up tables
 - protocol conversions
 - If you want to perform any of these functions, consider a control coprocessor module.
- additional serial ports for the control co-processor module
- keyswitch for reinitializing without cycling power
- 4-digit alphanumeric display for diagnostic reporting
 - If you want these options, choose an optional expander module for the control coprocessor.

system integration products

- the specific needs of your application. Your Allen-Bradley representative can offer suggestions or information.

programming software



- platform
- media type

Symbols

Empty, [31](#)

Numbers

1771-IR/B, RTD Input Module, 3-wire RTDs, [15](#)

1771-IXHR, High Resolution
Thermocouple/milliVolt Input Module, 8
T/C type B, E, J, K, R, S, T, [15](#)

1771-OFE1, Analog Output Module, 12 bit,
4 differential, voltage outputs 1000V
isolation, [15](#)

1771-OFE2, Analog Output Module, 12 bit,
4 differential, 1000V isolation, 4-20mA,
[15](#)

1771-OFE3, Analog Output Module, 12 bit,
4 differential, 1000V isolation, 0-50mA,
[15](#)



Allen-Bradley, a Rockwell Automation Business, has been helping its customers improve productivity and quality for more than 90 years. We design, manufacture and support a broad range of automation products worldwide. They include logic processors, power and motion control devices, operator interfaces, sensors and a variety of software. Rockwell is one of the worlds leading technology companies.



Worldwide representation.

Argentina • Australia • Austria • Bahrain • Belgium • Brazil • Bulgaria • Canada • Chile • China, PRC • Colombia • Costa Rica • Croatia • Cyprus • Czech Republic • Denmark • Ecuador • Egypt • El Salvador • Finland • France • Germany • Greece • Guatemala • Honduras • Hong Kong • Hungary • Iceland • India • Indonesia • Ireland • Israel • Italy • Jamaica • Japan • Jordan • Korea • Kuwait • Lebanon • Malaysia • Mexico • Netherlands • New Zealand • Norway • Pakistan • Peru • Philippines • Poland • Portugal • Puerto Rico • Qatar • Romania • Russia-CIS • Saudi Arabia • Singapore • Slovakia • Slovenia • South Africa, Republic • Spain • Sweden • Switzerland • Taiwan • Thailand • Turkey • United Arab Emirates • United Kingdom • United States • Uruguay • Venezuela • Yugoslavia

Allen-Bradley Headquarters, 1201 South Second Street, Milwaukee, WI 53204 USA, Tel: (1) 414 382-2000 Fax: (1) 414 382-4444

Allen-Bradley