

Allen - Bradley

1388 CONNECTION GUIDE

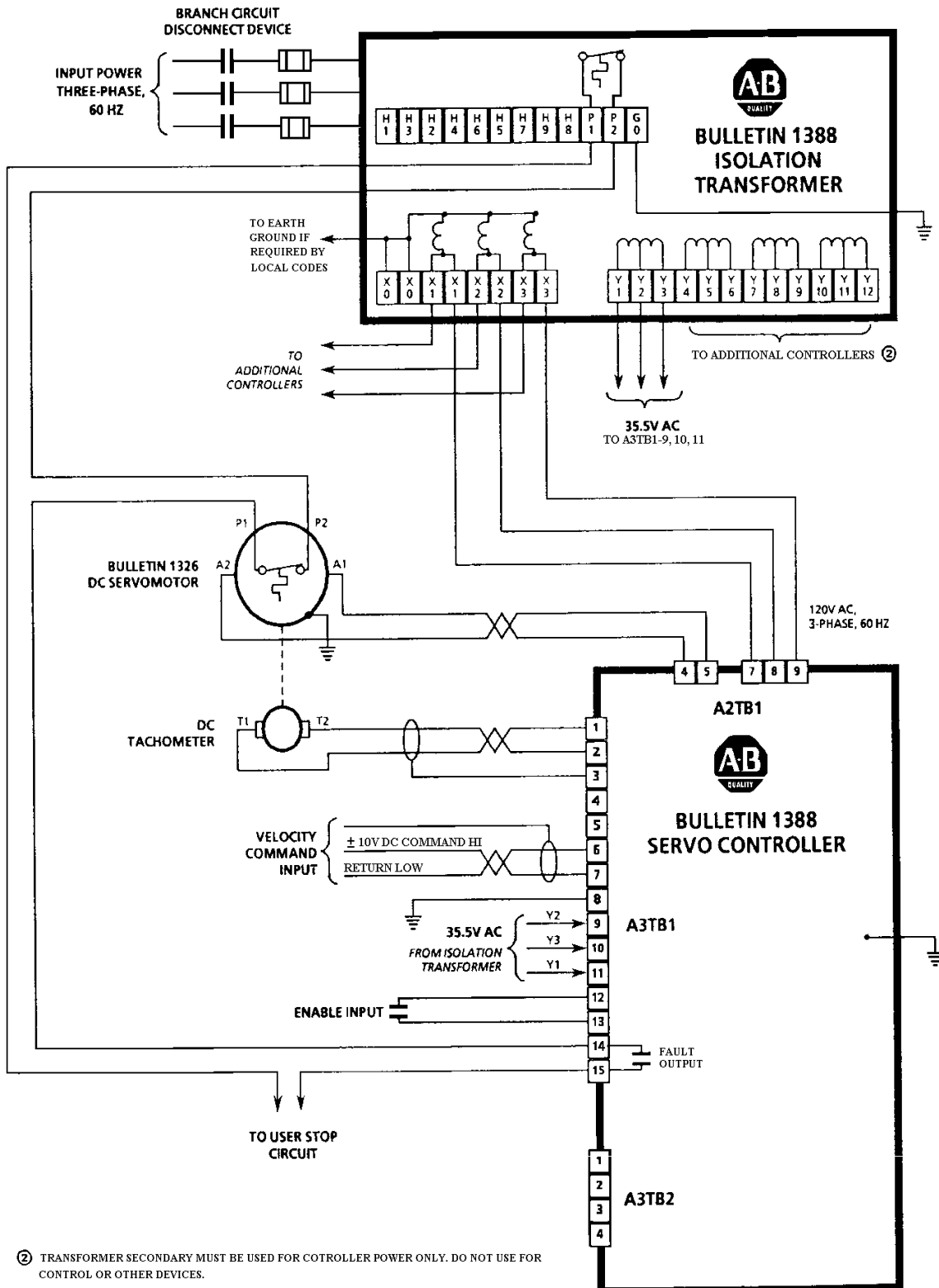

② TRANSFORMER SECONDARY MUST BE USED FOR COTROLLER POWER ONLY. DO NOT USE FOR CONTROL OR OTHER DEVICES.

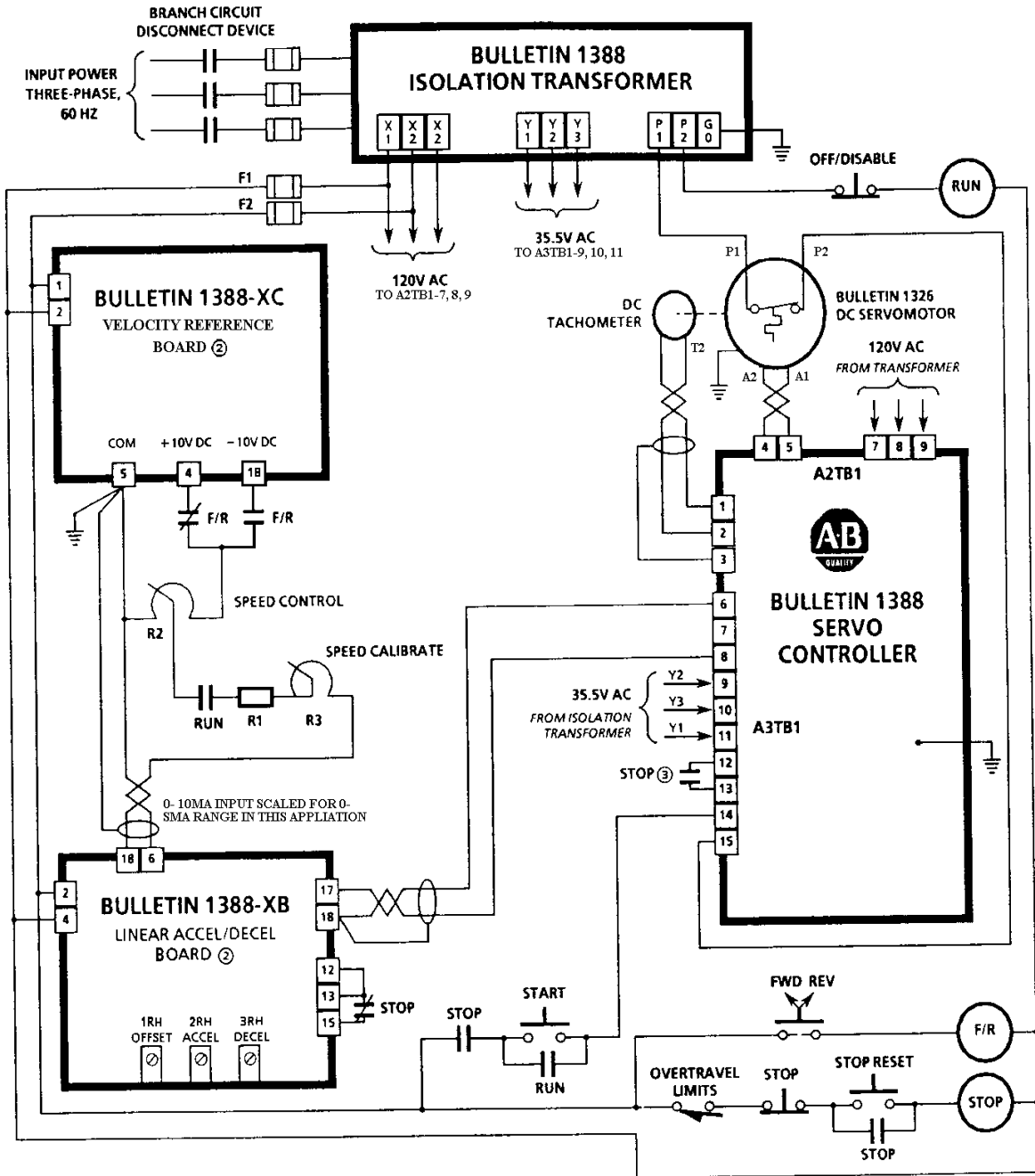

② MAXIMUM AVAILABLE CURRENT OUT OF 1388-XB=0.125A. MAXIMUM OF 4 1388-XB MODULES PER ONE 1388-XC.

③ DO NOT CYCLE STOP CONTACT MORE THAN TWICE AN HOUR.

Part	Catalog Number	Part	Catalog Number
Transformer	1388-Txxxxx	Fwd/Rev Switch	800T-H2A
Servo Controller	1388-AVxx	Stop Reset & Start P.B.	800T-A1A
Servomotor	1326DP-xxx-x	Stop & Off/Disable P.B.	800T-D6A
Linear Accel/Decel Board	1388-XB	R1 - 1.5k, 1/2 watt, + 10%	-
Velocity Reference board	1388-XC	Speed Cntrl (R2) - 500Ω, 1 watt	800T-UJ12
Stop, F/R & Run Relay	700-HC14A1 (Relay)	Speed Calibrate (R3) - 1K, 1/2 watt, + 10%	-
	700-HN103 (Base)	Fuse F1, F2 - 1A, 250V Min. Type MN Typ.	-

- Manually Controlled Bulletin 1388 System Interconnect Diagram

BULLETIN 1388 SERVO CONTROLLER

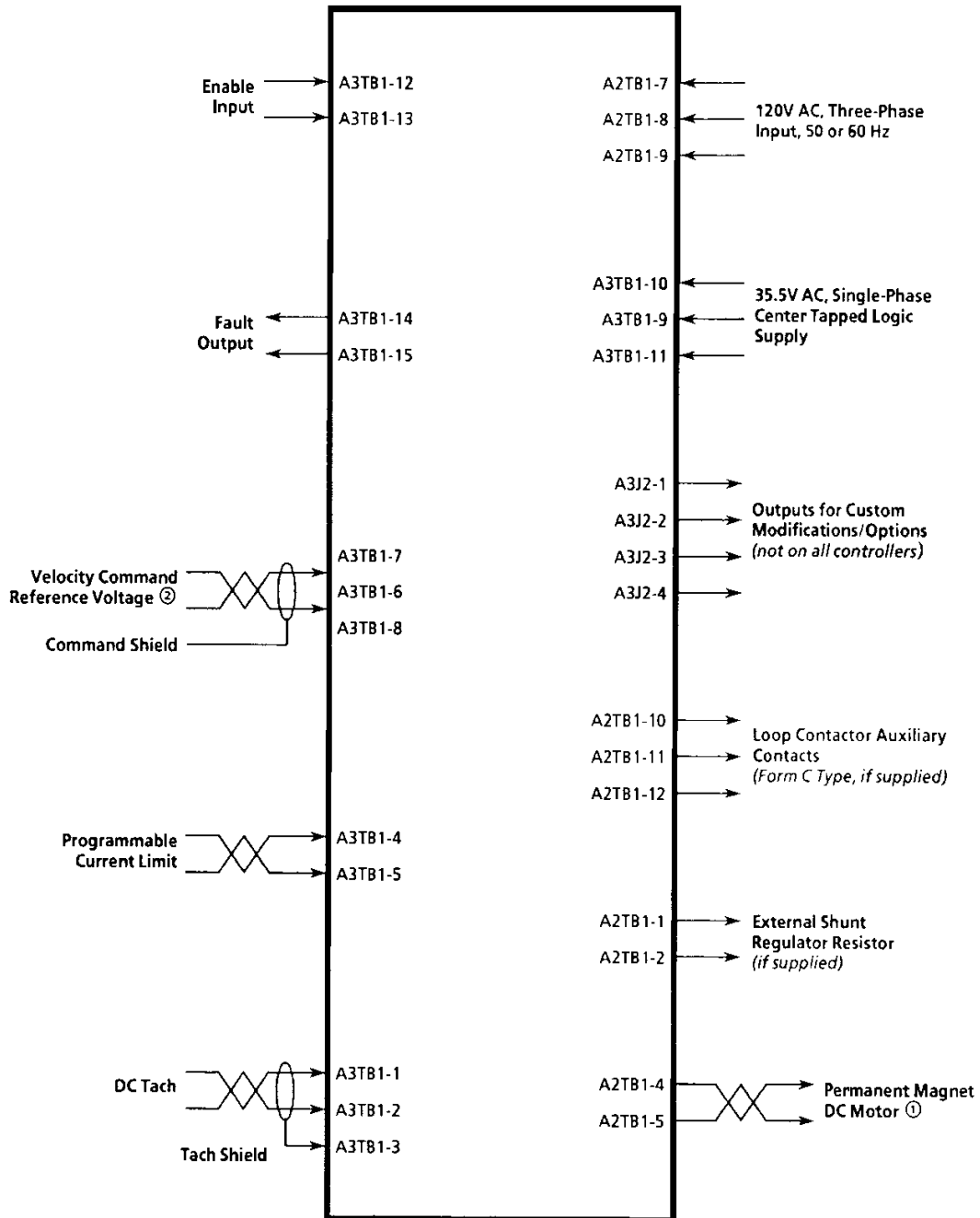

NOTES

① CABLE MUST BE TWISTED AT 6 TURNS PER FOOT.

② FOR A DIFFERENTIAL INPUT, CONNECT TO A3TB1-6 AND 7, A SINGLE ENDED INPUT MUST BE CONNECTED TO A3TB1-6 AND 8

- Bulletin 1388 Inputs and Outputs

AB PLCs

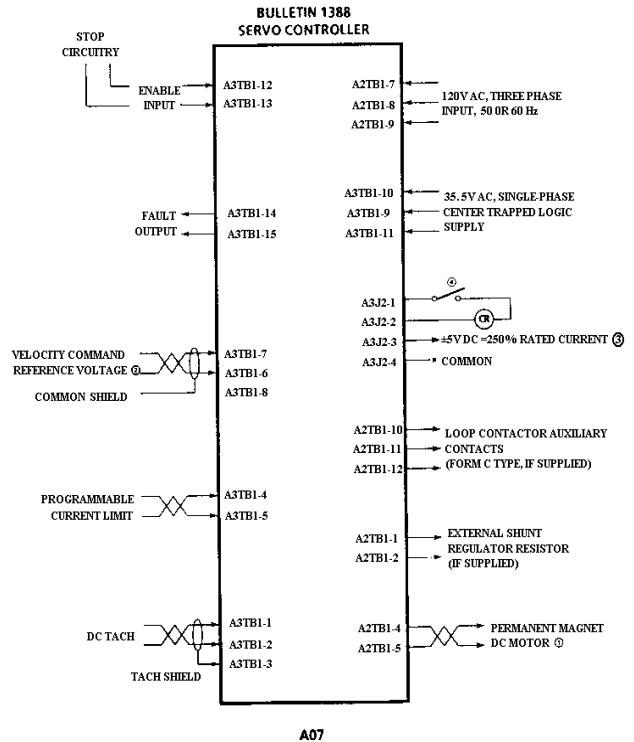
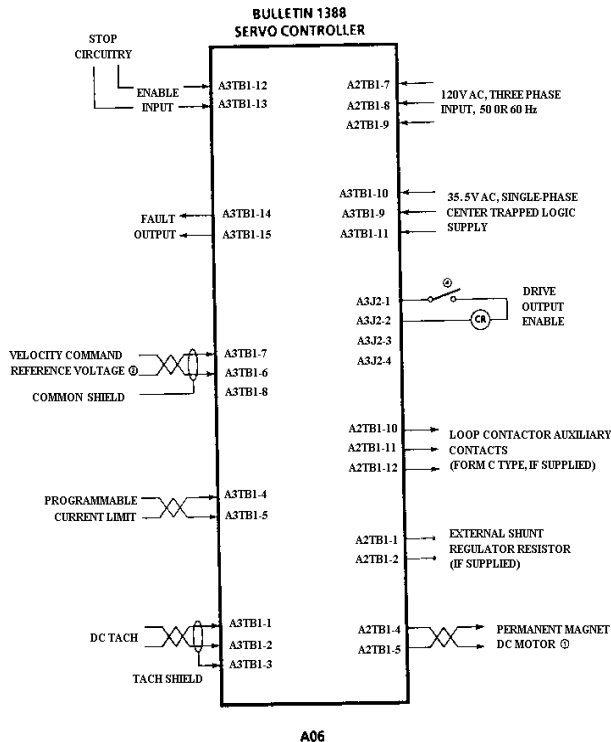
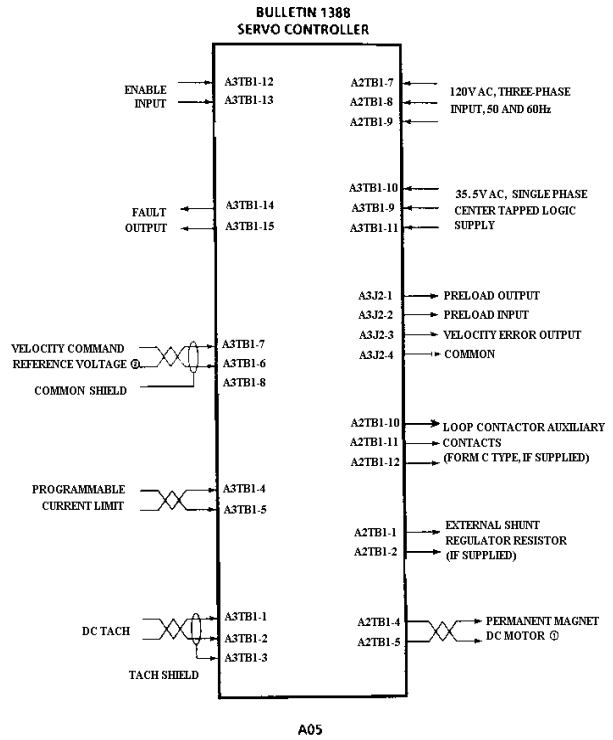
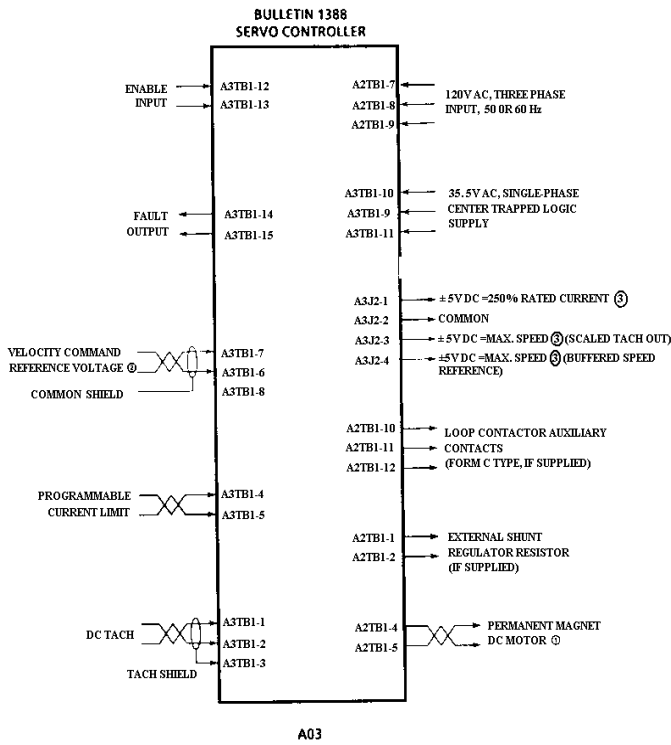

NOTES

- ③ MAXIMUM CURRENT DRAW = 5MA. USE METER WITH AT LEAST 10 MEGOHM IMPEDANCE.
- ④ CLOSING THIS SWITCH WILL ENABLE THE OUTPUT TRANSISTORS ON THE 1388. THE SWITCH MAY BE HE "DRIVE ENABLE" CONTACTS ON THE CNC, IMC, CREONICS OR OTHER MOTION CONTROLLER.

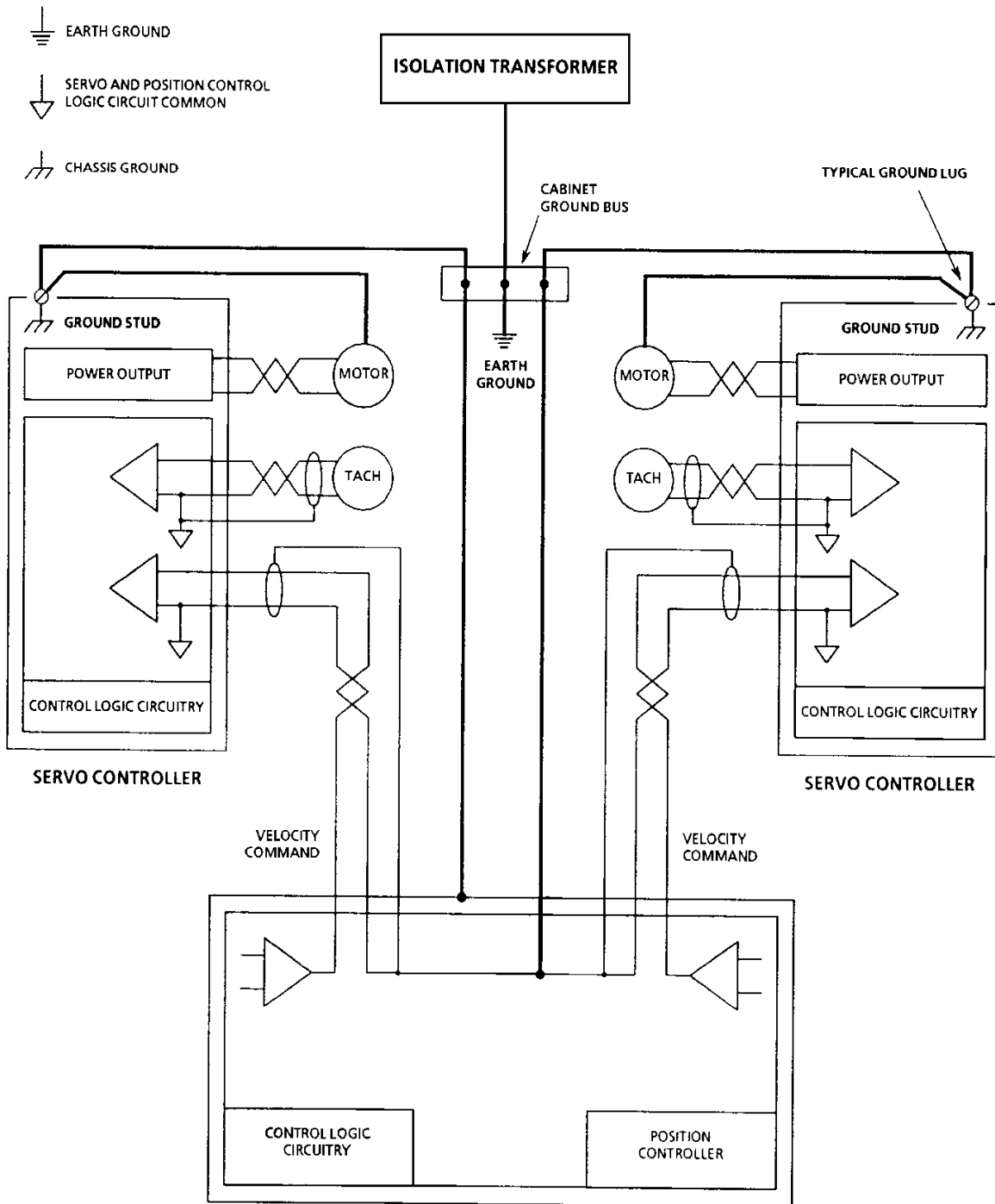

NOTES:

1. EARTH GROUNDS CONNECTED TO THE OUTER EDGE OF THE SERVO CONTROLLERS AND POSITION CONTROLLER ARE CONNECTED TO THE CHASSIS (METAL ENCLOSURE). THESE ARE SAFETY GROUNDS AND UNDER NORMAL CIRCUMSTANCES, DO NOT CARRY CURRENT.
2. THE VELOCITY COMMAND CAN BE CONNECTED IN EITHER A SINGLE-ENDED OR DIFFERENTIAL FASION (SINGLE-ENDED IS SHOWN). IN BOTH CASES, ONLY ONE CONTROL LOGIC CIRCUIT COMMON IS BROUGHT TO EARTH GROUND.
3. ON THE BULLETIN 1388, CONTROL LOGIC COMMONS ARE ACCESSIBLE AT: A3TB1-2, 3, 4 AND 8.

- System Grounding

AB PLCs

1771-QC INTERCONNECT DIAGRAM

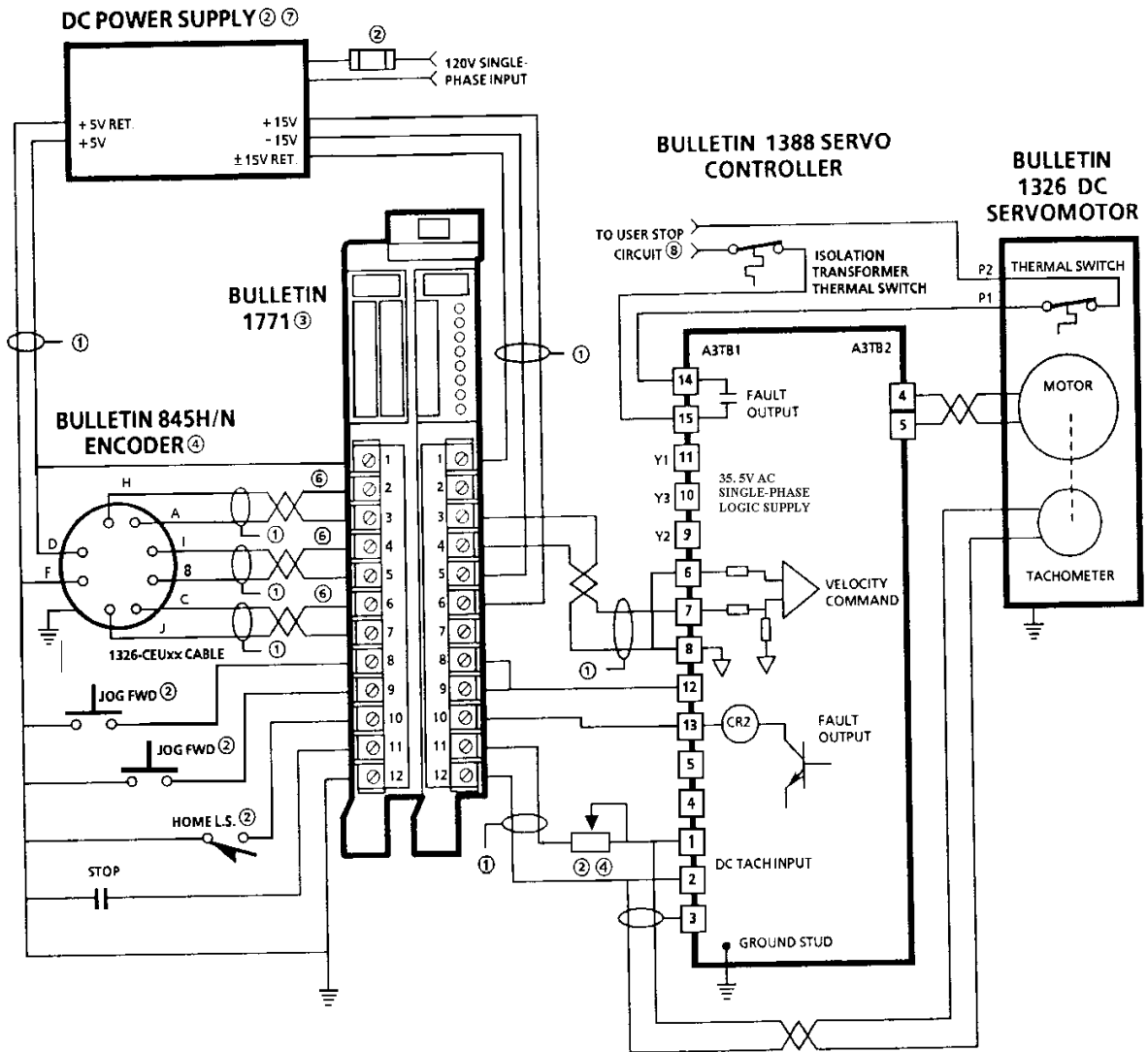

- ① CONNECT SHIELD DRAIN WIRE TO I/O CHASSIS MOUNTING BOLT OR GROUND BUS NEAR THE CHASSIS.
- ② USER SUPPLIED COMPONENT.
- ③ FOR INTERFACE DETAILS, REFER TO A-B PUBLICATION 1771-817 (SERIES A) OR 1771-832 (SERIES B), BULLETIN 1771 SERVO POSITIONING ASSEMBLY USER'S MANUAL, PUBLICATION 1771-6.5.25-DU1 AND PUBLICATION 1770-980, GENERAL GROUNDING AND FIELD WIRING PRACTICES FOR PROGRAMMABLE CONTROLLERS.
- ④ ADJUST FOR 50V MAXIMUM AT TERMINALS 11 AND 12 AT MAXIMUM MOTOR SPEED.
- ⑤ TYPICALLY DIFFERENTIAL LINE DRIVER OUTPUT.
- ⑥ BELDEN 9730 OR EQUIVALENT, 50 FEET (15.2 METERS) MAXIMUM.
- ⑦ +5V DC, 400MA MINIMUM, ±15V DC, 200 MA MINIMUM.
- ⑧ ISOLATE FROM ENCODER CONTROL LOGIC POWER. MOTOR THERMAL SWITCH IS NEAR MOTOR POWER AND CAN BE A SOURCE OF EMI INTERFERENCE.

BULLETIN 7300 INTERCONNECT DIAGRAM

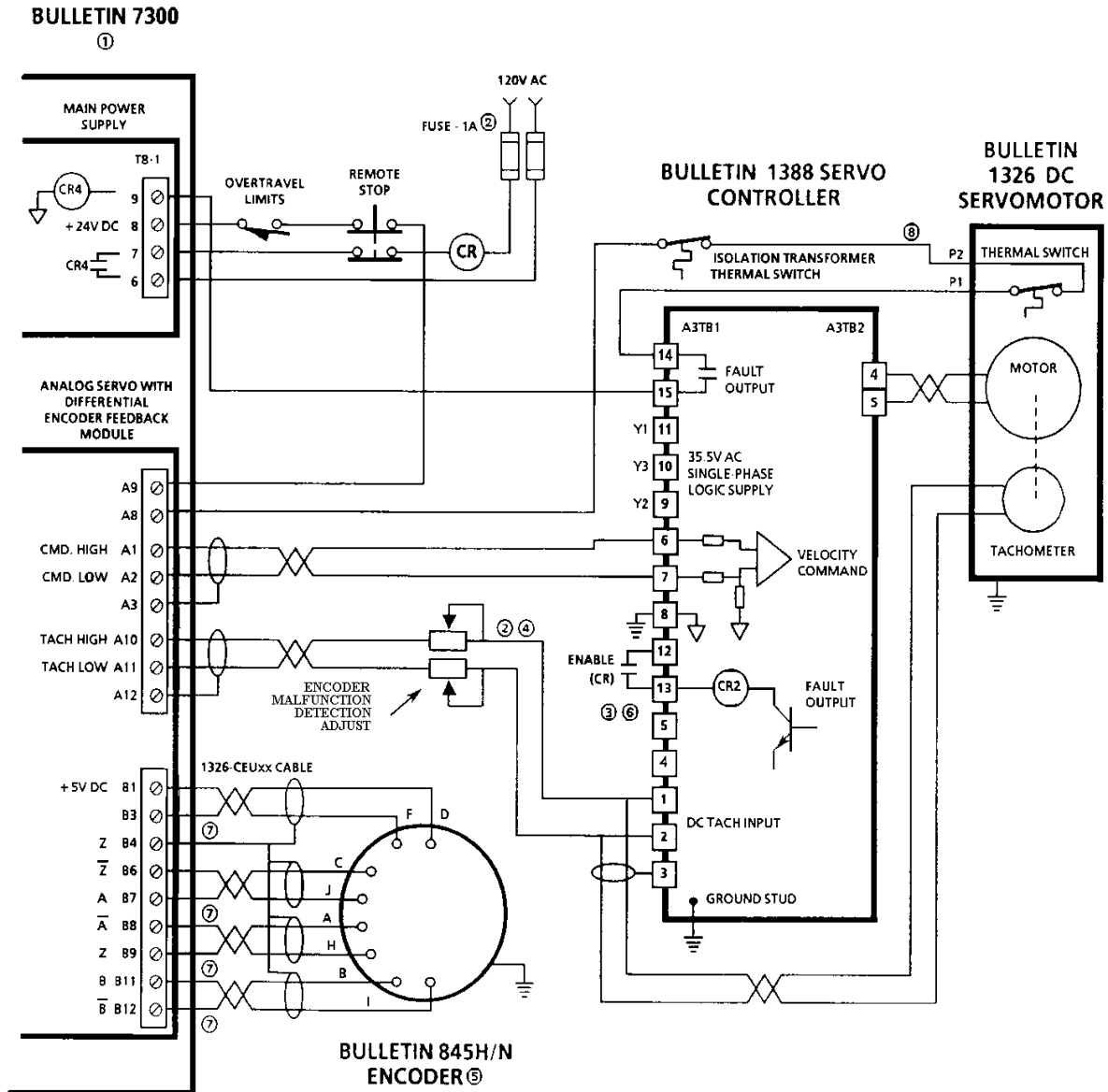

- ① FOR INTERFACE DETAILS, REFER TO A-B PUBLICATION 7300-805, *SERIES 7300 INTERFACE DESIGN MANUAL*.
- ② USER SUPPLIED COMPONENT
- ③ ENABLE RELAY IS SHOWN AS TYPICAL ONLY. BULLETIN 1388 CAN BE ENABLED WITHOUT AN EXTERNAL RELAY.
- ④ ADJUST FOR 50V MAXIMUM AT TERMINALS A10 AND A11 AT MAXIMUM MOTOR SPEED.
- ⑤ TYPICALLY DIFFERENTIAL LINE DRIVER OUTPUT.
- ⑥ A-B CATALOG NUMBER 700-HC14A1 (RELAY) AND NUMBER 700HN103 (MOUNTING BASE). RELAY IS 4PDT TO ENABLE UP TO FOUR SERVO CONTROLLERS.
- ⑦ BELDEN 9730 OR EQUIVALENT, 50 FEET (15.2 METERS) MAXIMUM. SHIELDS GROUNDED AT CONTROL ONLY.
- ⑧ ISOLATE FROM ENCODER CONTROL LOGIC POWER. MOTOR THERMAL SWITCH IS NEAR MOTOR POWER AND CAN BE A SOURCE OF EMI INTERFERENCE.

- 7300 Series CNC

AB PLCs

BULLETIN 8200 INTERCONNECT DIAGRAM

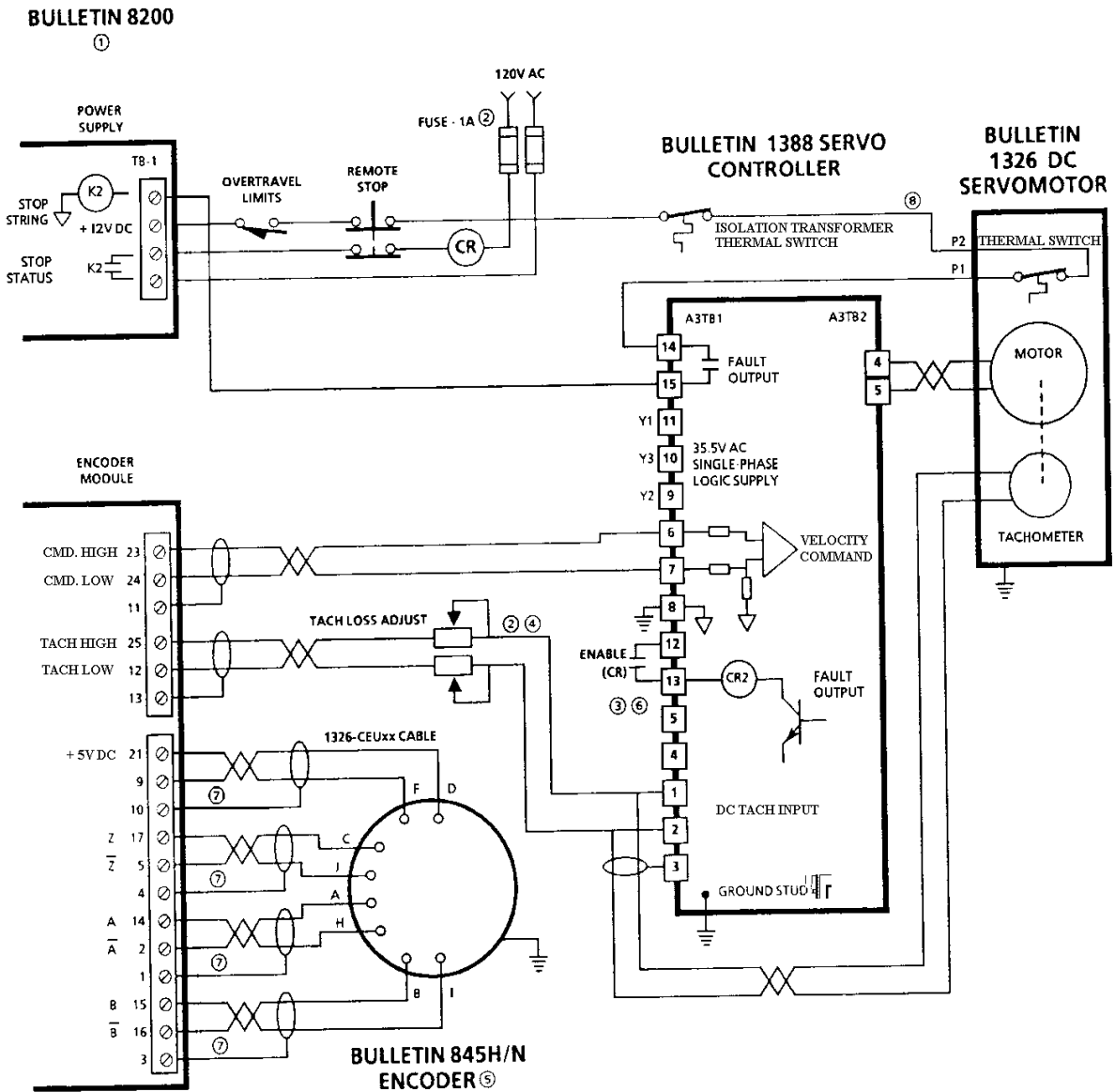

- ① FOR INTERFACE DETAILS, REFER TO A-B PUBLICATION 8200-4.1, *SERIES 820 CNC INTERFACE DESIGN MANUAL*.
- ② USER SUPPLIED COMPONENT.
- ③ ENABLE RELAY IS SHOWN AS TYPICAL ONLY. BULLETIN 1388 CAN BE ENABLED WITHOUT AN EXTERNAL RELAY.
- ④ TACH LOSS ADJUSTMENT WOULD TYPICALLY BE A POTENTIOMETER OR FIXED RESISTOR SET TO: $R(OHMS) = 1800 \times (V MAX - 10)$. WHERE: V MAX = MAX TACH VOLTS AT MAX SPEED.
- ⑤ TYPICALLY DIFFERENTIAL LINE DRIVER OUTPUT.
- ⑥ A-B CATALOG NUMBER 700-HC14A1 (RELAY) AND NUMBER 700HN103 (MOUNTING BASE). RELAY IS 4PDT TO ENABLE UP TO FOUR SERVO CONTROLLERS.
- ⑦ BELDEN 9730 OR EQUIVALENT, 50 FEET (15.2 METERS) MAXIMUM. SHIELDS GROUNDED AT CONTROL ONLY.
- ⑧ ISOLATE FROM ENCODER CONTROL LOGIC POWER. MOTOR THERMAL SWITCH IS NEAR MOTOR POWER AND CAN BE A SOURCE OF EMI INTERFERENCE.

BULLETIN 8400 INTERCONNECT DIAGRAM

BULLETIN 8400 ① ④

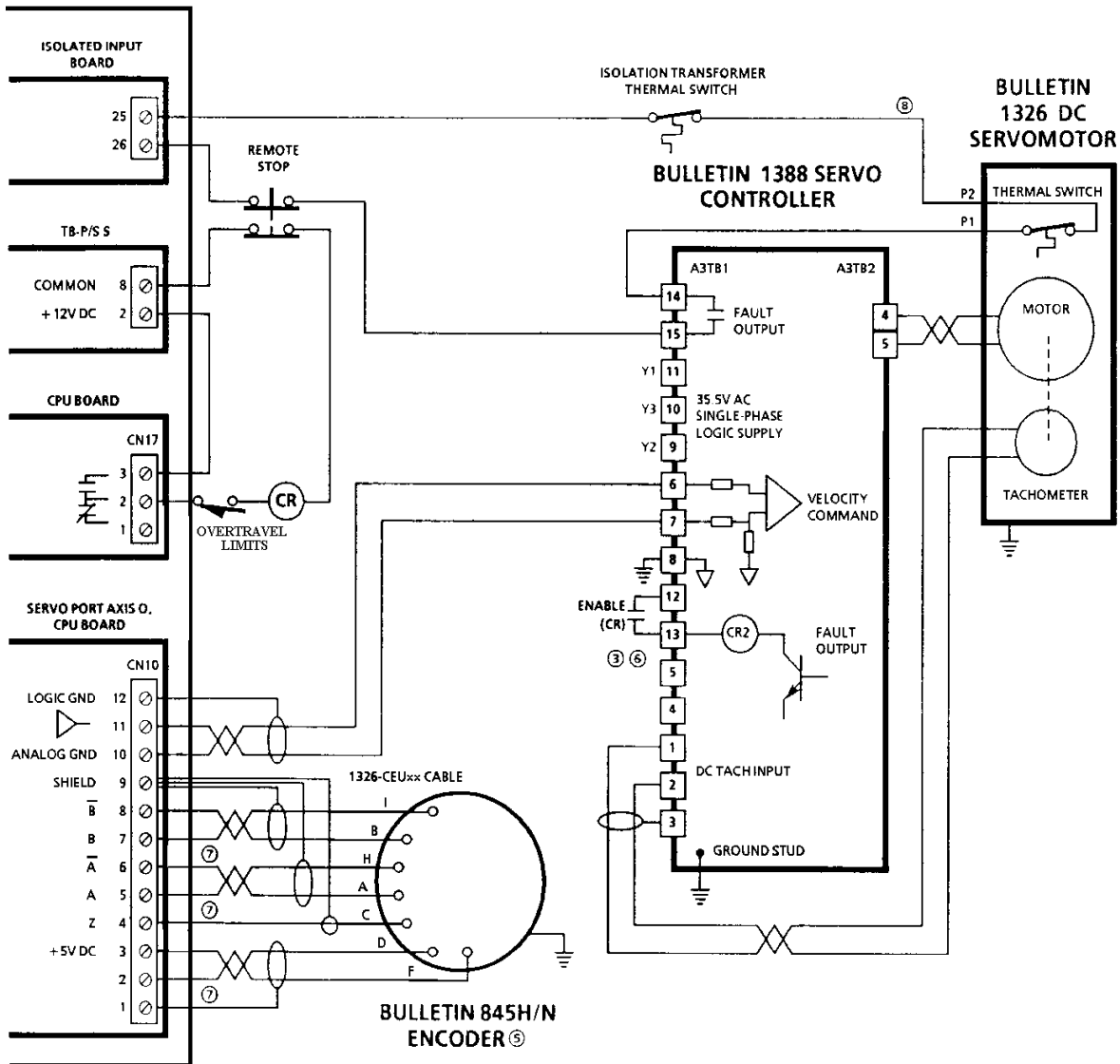

- ① FOR INTERFACE DETAILS, REFER TO A-B PUBLICATION 8400-4.1, *SERIES 8400 CNC INTERFACE DESIGN MANUAL*.
- ② USER SUPPLIED COMPONENT.
- ③ ENABLE RELAY IS SHOWN AS TYPICAL ONLY. BULLETIN 1388 CAN BE ENABLED WITHOUT AN EXTERNAL RELAY.
- ④ OEM KIT VERSION SHOWN. NO DRIVES VERSION WOULD REQUIRE AXIS INTERCONNECT BOARD.
- ⑤ TYPICALLY DIFFERENTIAL LINE DRIVER OUTPUT.
- ⑥ A-B CATALOG NUMBER 700-HC14A1 (RELAY) AND NUMBER 700HN103 (MOUNTING BASE). RELAY IS 4PDT TO ENABLE UP TO FOUR SERVO CONTROLLERS.
- ⑦ BELDEN 9730 OR EQUIVALENT, 50 FEET (15.2 METERS) MAXIMUM. SHIELDS GROUNDED AT CONTROL ONLY.
- ⑧ ISOLATE FROM ENCODER CONTROL LOGIC POWER. MOTOR THERMAL SWITCH IS NEAR MOTOR POWER AND CAN BE A SOURCE OF EMI INTERFERENCE.

- 8400 Series CNC

AB PLCs

BULLETIN 8600 INTERCONNECT DIAGRAM

BULLETIN 8600 ① ④

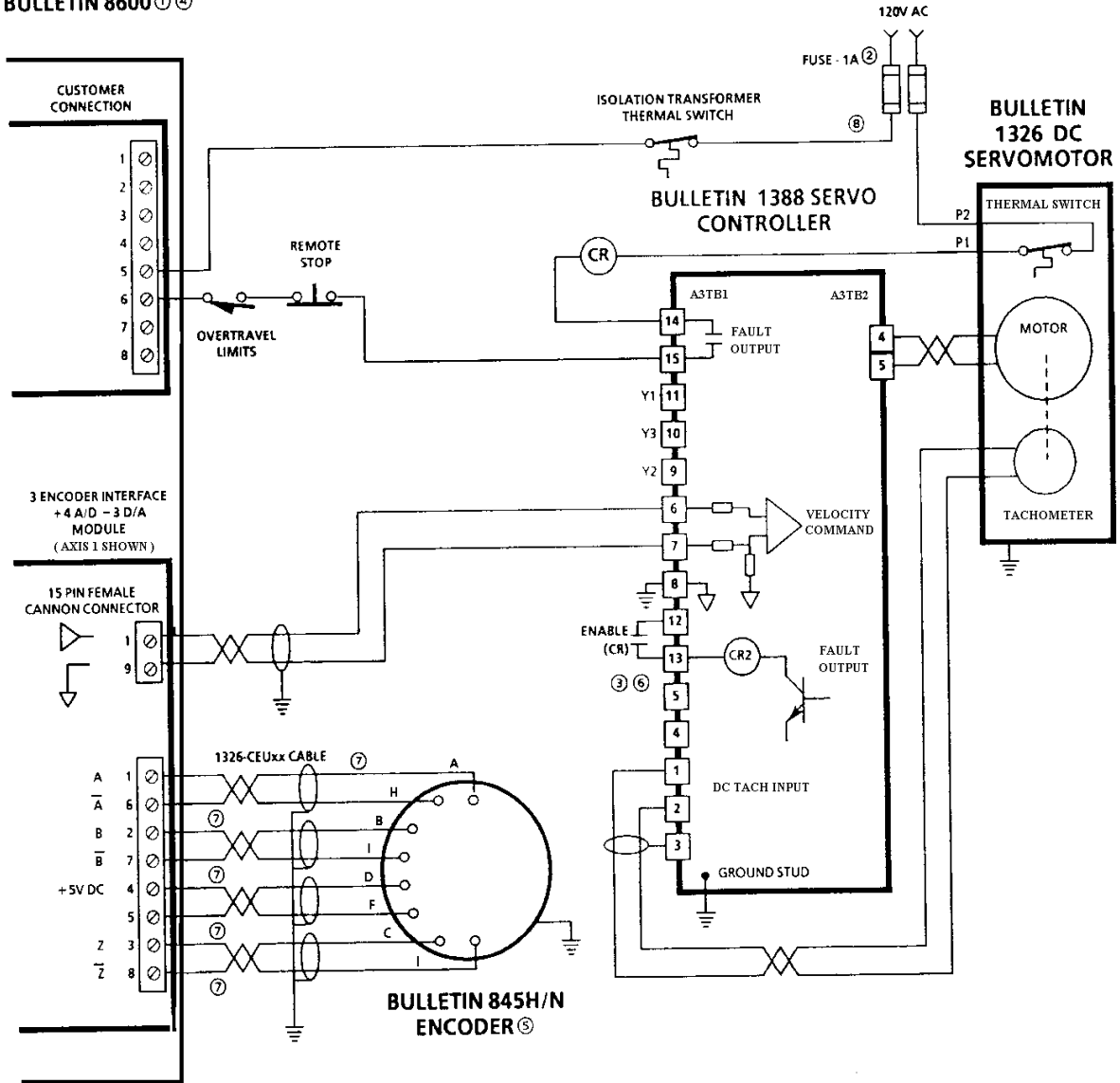

- ① FOR INTERFACE DETAILS, REFER TO A-B PUBLICATION 8600 4.1, *SERIES 8600 CNC INTERFACE DESIGN MANUAL*.
- ② USER SUPPLIED COMPONENT.
- ③ ENABLE RELAY IS SHOWN AS TYPICAL ONLY. BULLETIN 1388 CAN BE ENABLED WITHOUT AN EXTERNAL RELAY.
- ④ TYPICAL 3 AXIS SYSTEM SHOWN FOR SERIES 8605, 8610 AND 8650 CNC.
- ⑤ TYPICALLY DIFFERENTIAL LINE DRIVER OUTPUT.
- ⑥ A-B CATALOG NUMBER 700-HC14A1 (RELAY) AND NUMBER 700HN103 (MOUNTING BASE). RELAY IS 4PDT TO ENABLE UP TO FOUR SERVO CONTROLLERS.
- ⑦ BELDEN 9730 OR EQUIVALENT, 50 FEET (15.2 METERS) MAXIMUM. SHIELDS GROUNDED AT CONTROL ONLY.
- ⑧ ISOLATE FROM ENCODER CONTROL LOGIC POWER. MOTOR THERMAL SWITCH IS NEAR MOTOR POWER AND CAN BE A SOURCE OF EMI INTERFERENCE.

IMC 120 INTERCONNECT DIAGRAM

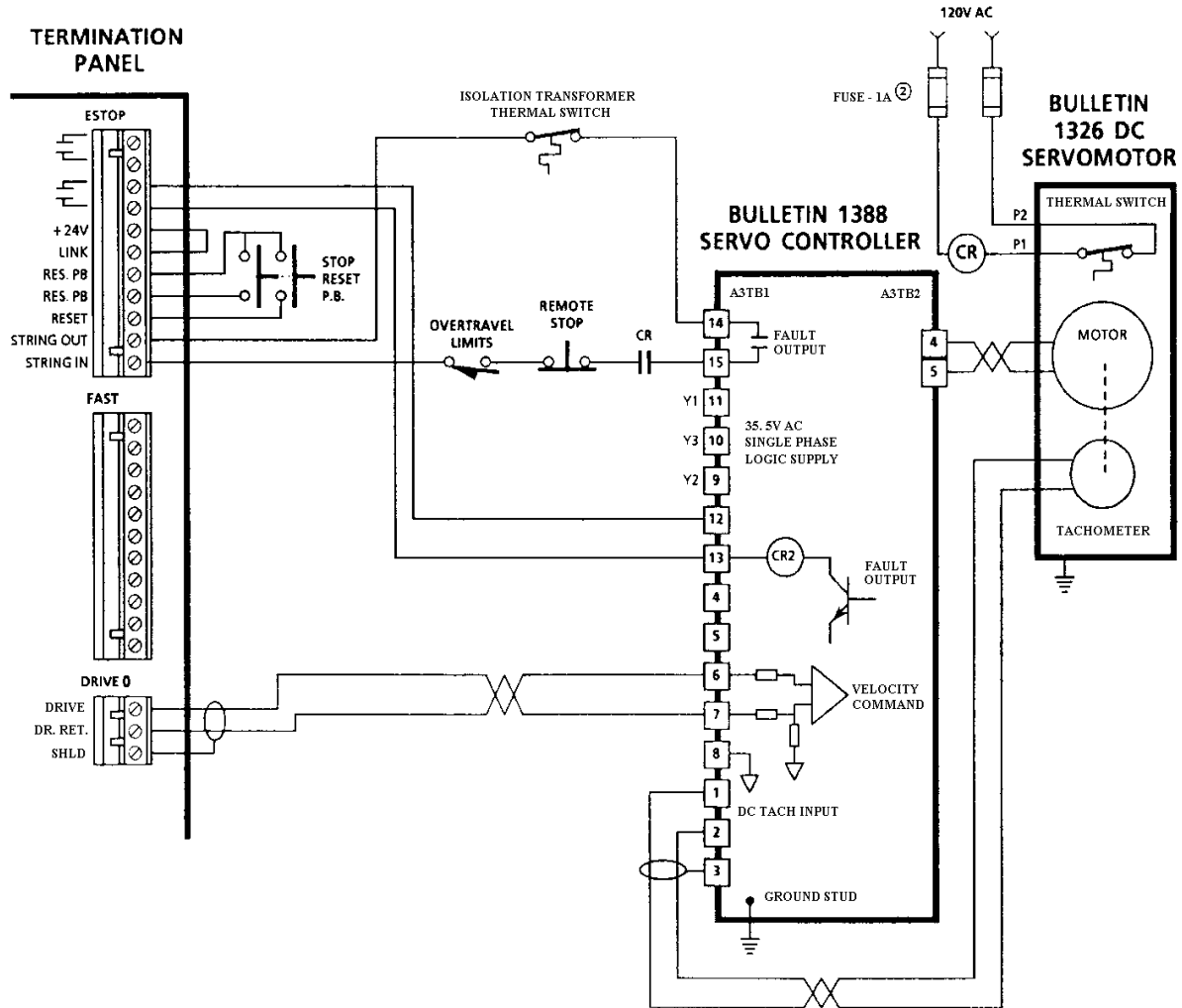

② USER SUPPLIED COMPONENT.

- IMC 120

AB PLCs

IMC 123 INTERCONNECT DIAGRAM

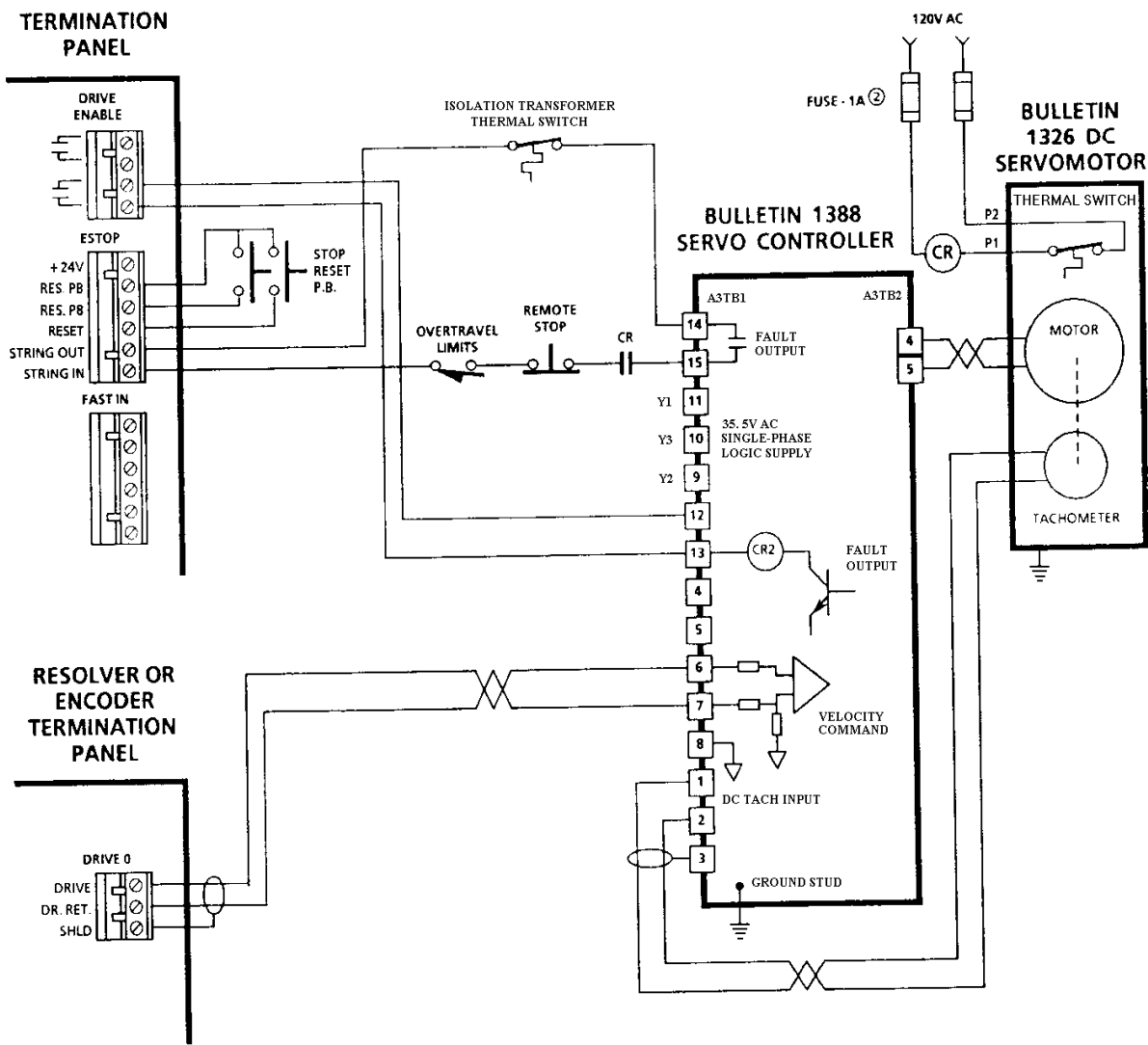

② USER SUPPLIED COMPONENT.

CREONICS MAX & MAX4/CONTROL INTERCONNECT DIAGRAM

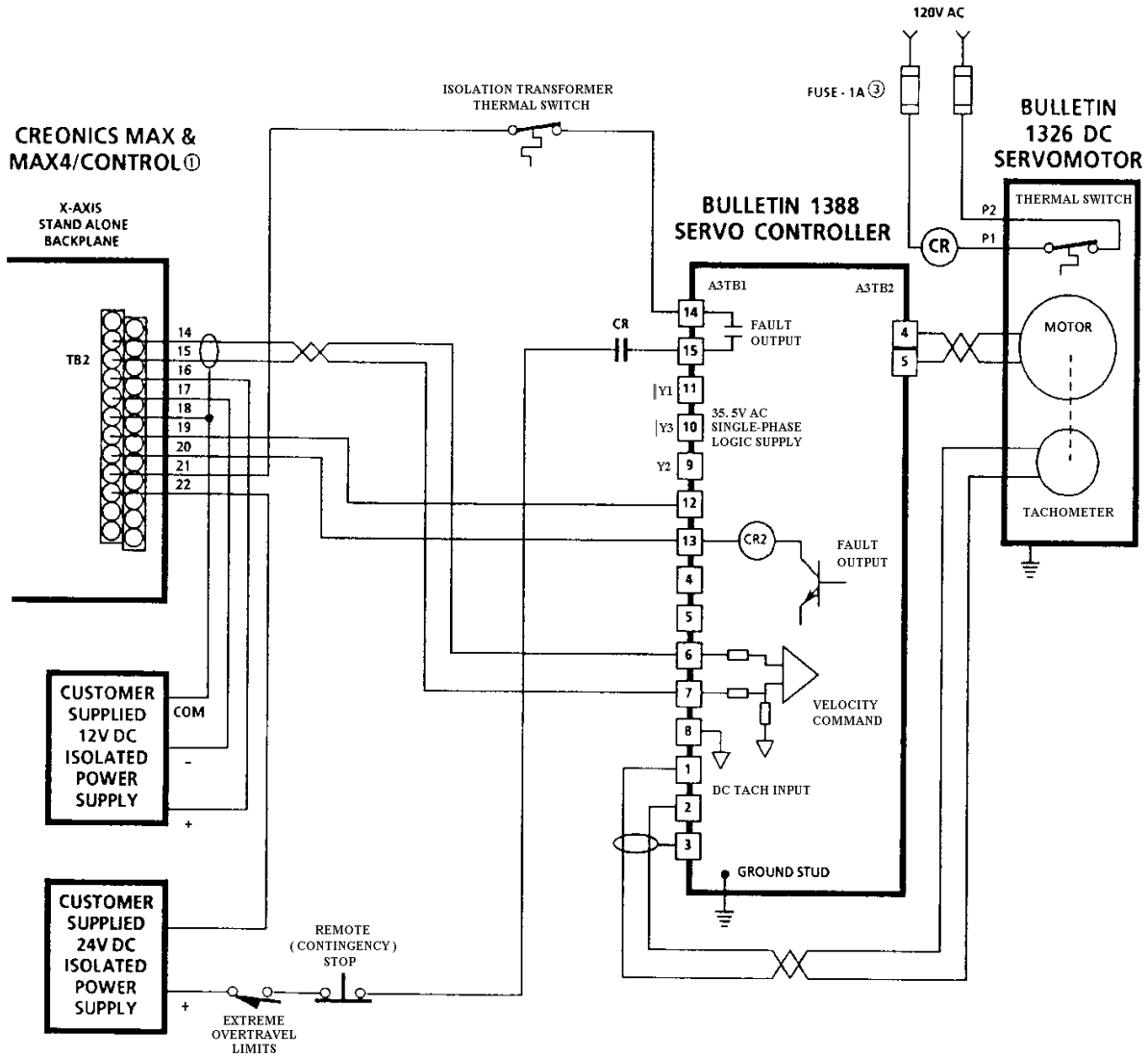

IMPORTANT:

IF USING A 1388-AVXX-C (TORQUE BLOCK) – SET MAX TO "PWM/CURRENT."
 IF USING A STANDARD 1388 (VELOCITY LOOP) – SET MAX TO "VELOCITY."

① REFER TO THE MAX OR MAX4/CONTROL INSTALLATION AND SETUP MANUAL FOR DETAILS.

③ USER SUPPLIED COMPONENT.

– MAX & MAX4/Control

AB PLCs