



Interconnect Cable (Cat. No. 1794-CE1 and -CE3)

Installing the Cable for DIN Rail Mounting



ATTENTION: Do not use more than one cable per system.

To install the cable on an existing DIN rail mounted system, proceed as follows:

1. Remove the plug from the male flexbus connector.
2. Insert cable connector (1) into mating connector on right side of the terminal base unit (2). Press firmly to seat.

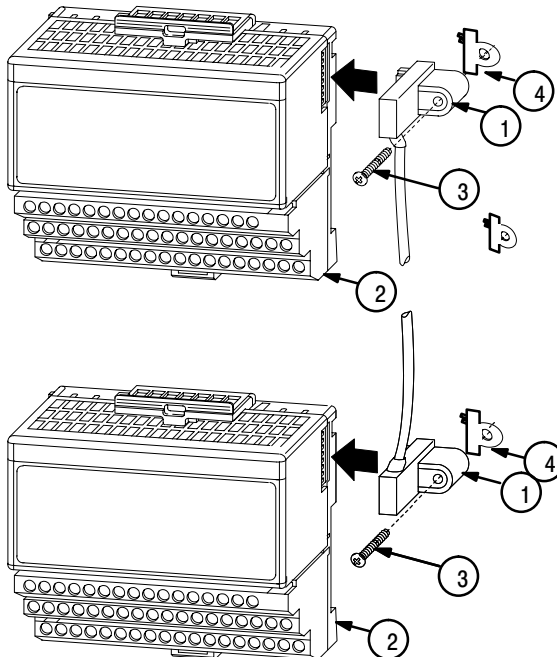

3. Use a drill bit or awl small enough to go through the hole in the cable to mark the position of the hole on the mounting surface.
4. Remove the cable by pulling straight out of the terminal base unit.
5. Using the mark made in step 3, drill and tap a hole for the 6-32 screw (3) supplied in your kit.

Important: Make sure to cover any modules which may be located under the area on the panel which you are drilling to prevent chips from falling into the modules and shorting out the backplane.

6. Push the snap-on washer (4) into the cable as indicated. The washer will lock onto the cable. Reinstall the cable in the side of the terminal base unit. The washer will lock into the mating module and secure the cable to the module.
7. Push the 6-32 screw through the hole in the cable end and screw it into the DIN rail until secure.
8. Repeat the above procedure for the other end of the cable.

Installing the Cable for Panel Mounting



ATTENTION: Do not use more than one cable per system.

To install the cable when the system is wall/panel mounted, proceed as follows:

1. Remove the plug from the male flexbus connector.
2. Insert cable connector (1) into mating connector on right side of the terminal base unit (2). Press firmly to seat.

Important: If you are initially laying out your system, refer to the mounting/drilling dimensions that are included with the mounting kit.

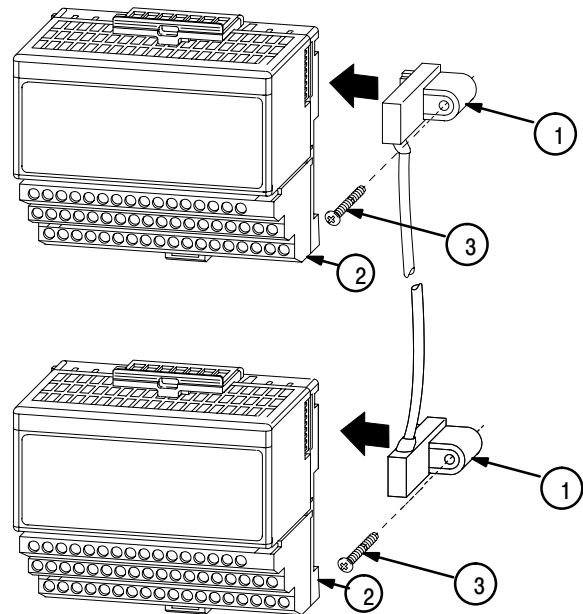

3. Use a drill bit or awl small enough to go through the hole in the cable to mark the position of the hole on the mounting surface.
4. Remove the cable by pulling straight out of the terminal base unit.
5. Using the mark made in step 3, drill and tap a hole for the 6-32 screw (3) supplied in your kit.

Important: Make sure to cover any modules which may be located under the area on the panel which you are drilling to prevent chips from falling into the modules and shorting out the backplane.

6. Reinstall the cable in the side of the terminal base unit.
7. Push the 6-32 screw through the hole in the cable end and screw into the panel/wall until secure.
8. Repeat the above procedure for the other end of the cable.

Amer-Bradley Parts

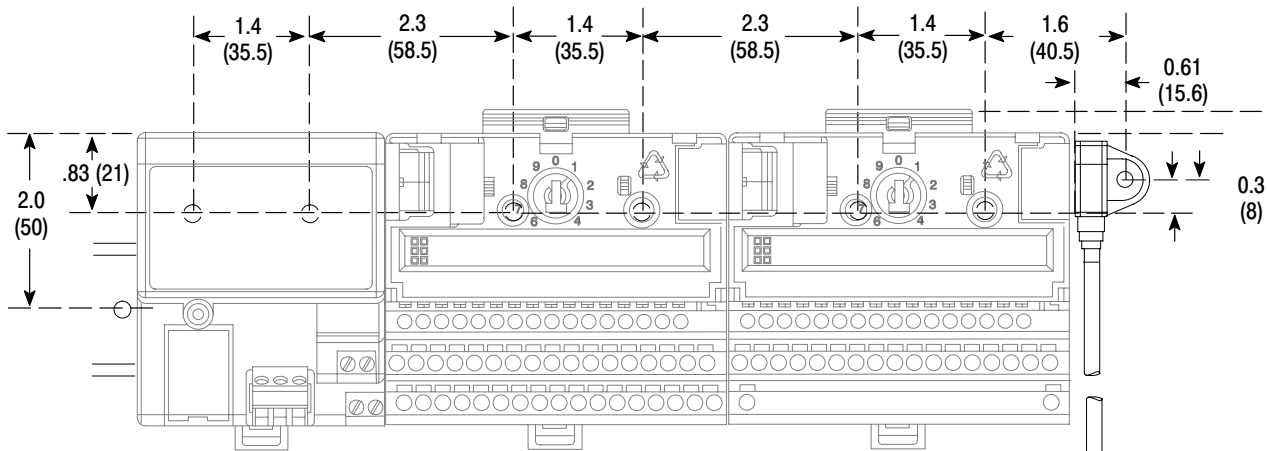

Inches
(Millimeters)



ATTENTION: Be careful of metal chips when drilling cable mounting holes. Do not drill holes above a system that has any modules installed.

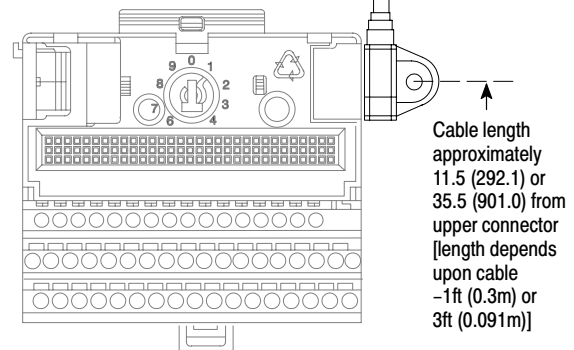

Cable length approximately 11.5 (292.1) or 35.5 (901.0) from upper connector [length depends upon cable] -1ft (0.3m) or 3ft (0.091m)



Allen-Bradley, a Rockwell Automation Business, has been helping its customers improve productivity and quality for more than 90 years. We design, manufacture and support a broad range of automation products worldwide. They include logic processors, power and motion control devices, operator interfaces, sensors and a variety of software. Rockwell is one of the world's leading technology companies.



Worldwide representation.

Argentina • Australia • Austria • Bahrain • Belgium • Brazil • Bulgaria • Canada • Chile • China, PRC • Colombia • Costa Rica • Croatia • Cyprus • Czech Republic • Denmark • Ecuador • Egypt • El Salvador • Finland • France • Germany • Greece • Guatemala • Honduras • Hong Kong • Hungary • Iceland • India • Indonesia • Ireland • Israel • Italy • Jamaica • Japan • Jordan • Korea • Kuwait • Lebanon • Malaysia • Mexico • Netherlands • New Zealand • Norway • Pakistan • Peru • Philippines • Poland • Portugal • Puerto Rico • Qatar • Romania • Russia-CIS • Saudi Arabia • Singapore • Slovakia • Slovenia • South Africa, Republic • Spain • Sweden • Switzerland • Taiwan • Thailand • Turkey • United Arab Emirates • United Kingdom • United States • Uruguay • Venezuela • Yugoslavia

Allen-Bradley Headquarters, 1201 South Second Street, Milwaukee, WI 53204 USA, Tel: (1) 414 382-2000 Fax: (1) 414 382-4444