

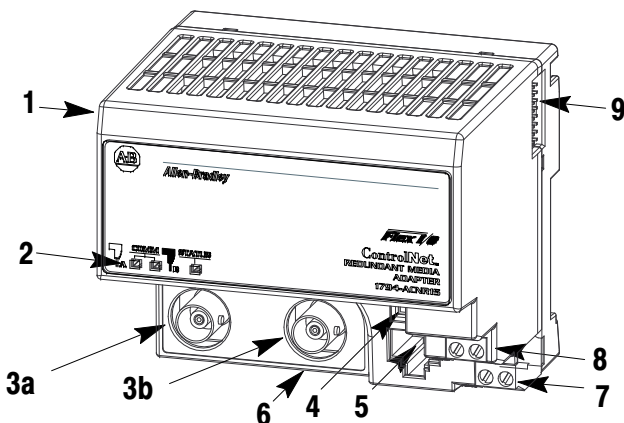

# Installation Instructions

## FLEX I/O ControlNet Redundant Media Adapter

(Cat. No. 1794-ACNR15)



### Component Identification

1	ControlNet Adapter module
2	Indicators
3a	ControlNet network cable BNC connector A
3b	ControlNet network cable BNC connector B
4	ControlNet Node selection thumbwheel switches
5	ControlNet programming terminal connector port
6	Module locking tab
7	+24V dc connections
8	24V common connections
9	Flexbus connector

## **European Union Directive Compliance**

If this product has the CE mark it is approved for installation within the European Union and EEA regions. It has been designed and tested to meet the following directives.

### **EMC Directive**

This product is tested to meet Council Directive 89/336/EEC Electromagnetic Compatibility (EMC) and the following standards, in whole or in part, documented in a technical construction file:

- EN 50081-2EMC – Generic Emission Standard, Part 2 – Industrial Environment
- EN 50082-2EMC – Generic Immunity Standard, Part 2 – Industrial Environment

This product is intended for use in an industrial environment.

### **Low Voltage Directive**

This product is tested to meet Council Directive 73/23/EEC Low Voltage, by applying the safety requirements of EN 61131-2 Programmable Controllers, Part 2 – Equipment Requirements and Tests.

For specific information required by EN 61131-2, see the appropriate sections in this publication, as well as the following Allen-Bradley publications:

- Industrial Automation Wiring and Grounding Guidelines For Noise Immunity, publication 1770-4.1
- Guidelines for Handling Lithium Batteries, publication AG-5.4
- Automation Systems Catalog, publication B112

This equipment is classified as open equipment and must be mounted in an enclosure during operation to provide safety protection.

## Mounting the Adapter on a DIN Rail before Installing Modules

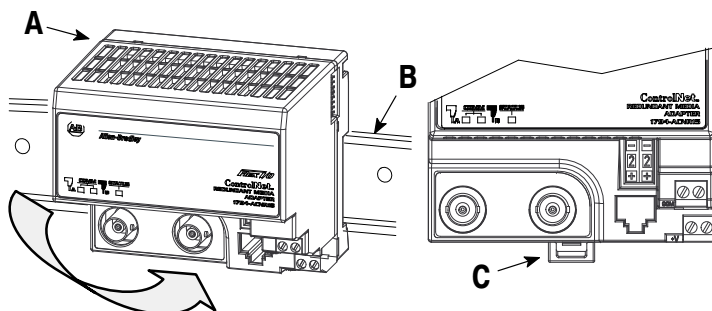

1. Position the ControlNet adapter module (A) on a 35 x 7.5mm DIN rail (B) (A-B pt. no. 199-DR1; 46277-3; EN 50022) at a slight angle.
2. Hook the lip on the rear of the adapter (A) onto the top of the DIN rail (B), and rotate the adapter module onto the rail.
3. Press the adapter module down onto the DIN rail until flush. Locking tab (C) will snap into position and lock the adapter module to the DIN rail.
4. If the adapter module does not lock in place, use a screwdriver or similar device to move the locking tab down while pressing the adapter module flush onto the DIN rail and release the locking tab to lock the adapter module in place. If necessary, push up on the locking tab to lock.
5. Connect the adapter wiring as shown under “Wiring” later in this document.

## Mounting (or Replacing) the Adapter on an Existing System

1. Disconnect the BNC connectors from the front of the adapter.
2. Disconnect any wiring jumpered to the adjacent terminal base.
3. Using a screwdriver or similar tool, open the lock and remove the module from the base unit to which the adapter will be attached.
4. Push the flexbus connector toward the right side of the terminal base to unplug the backplane connection.



**ATTENTION:** Make certain that the flexbus connector is completely clear of the adapter. The slide must be completely to the right and the raised spot on the slide visible.

5. Release the locking tab and remove the adapter.
6. Before installing the new adapter, notice the notch on the right rear of the adapter. This notch accepts the hook on the terminal base unit. The notch is open at the bottom. The hook and adjacent connection point keep the terminal base and adapter tight together, reducing the possibility of a break in communication over the backplane.

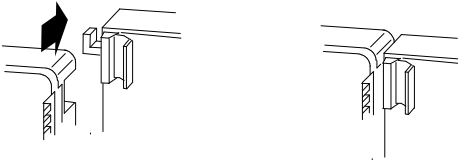

**ATTENTION:** Make certain that the hook on the terminal base is properly hooked into the adapter. Failure to lock the hook into the adjacent base/adapter can result in loss of communication on the backplane.

7. Complete the adapter mounting as shown below.

Push down and in at the same time to lock the adapter to the DIN rail.

When the adapter is locked onto the DIN rail, gently push the flexbus connector into the adapter to complete the backplane.

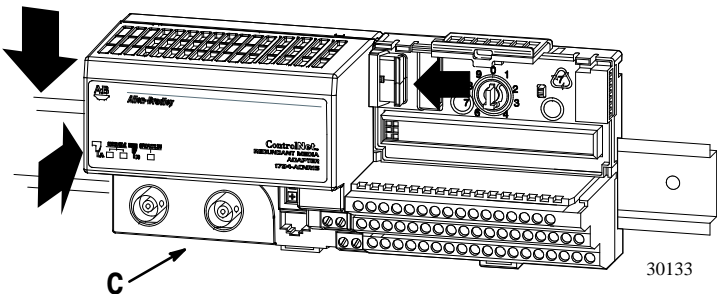

- If the adapter module does not lock in place, use a screwdriver or similar device to move the locking tab **C** down while pressing the adapter module flush onto the DIN rail. Then release the locking tab to lock the adapter module in place. If necessary, push up on the locking tab to lock.
- Reinstall the module into the terminal base unit.

## Wiring

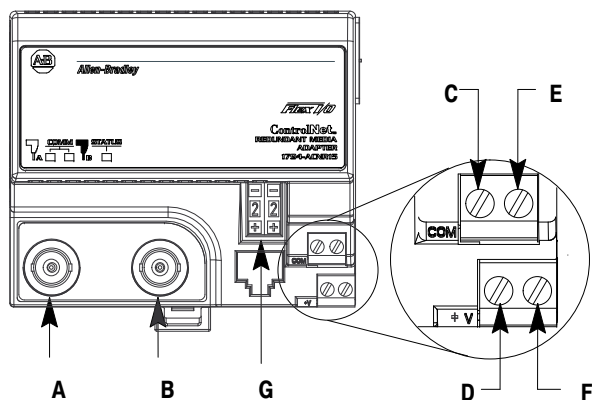

**ATTENTION:** When connecting wiring, torque terminal screws to 7-9 inch-pounds

- Connect the ControlNet network cable to connector, terminal **A**.
- Connect the redundant ControlNet network cable to connector **B**.
- Connect 24V common to the left side of the upper connector, terminal **C**.
- Connect +24V dc input to the left side of the lower connector, terminal **D**.
- Connections **E** and **F** are used to pass 24V dc power (**F**) and 24V common (**E**) to the next module in the series (if required).
- Set the network address using the 2-position thumbwheel switch **G**. Valid settings range from 01 to 99. Press either the + or - buttons to change the number.

## Indicators

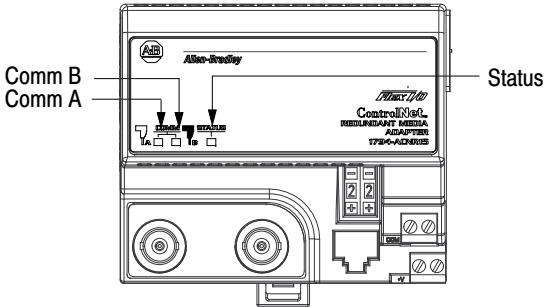

Status Indicators	Probable Cause
<b>Comm A and Comm B Simultaneously</b>	
Off	No power, or reset
Red	Adapter inoperative
Red/Grn - (flashing alternately)	Adapter self-test
Red/Off - (flashing alternately)	Bad node configuration (duplicate address)
<b>Comm A or Comm B (individually)</b>	
Off	Channel disabled
Green	Channel operational
Flashing Grn/Off	Temporary network errors
Flashing Red/Off	Cable fault, broken cable, redundancy warning
Flashing Red/Grn	Bad network configuration
<b>Status Indicator</b>	
Off	No power
Flashing Grn	On-line but not connected
Green	On-line, link okay, connected
Flashing Red	I/O module removed, wrong I/O module inserted, FLASH program update in progress
Red	Critical - adapter failure

**1794-ACNR15 Specifications**

I/O Capacity	8 modules
Power Supply	<b>Note:</b> In order to comply with CE Low Voltage Directives, you must use a Safety Extra Low Voltage (SELV) or a Protected Extra Low Voltage (PELV) power supply to power this adapter.
Input Voltage Rating	24V dc nominal
Input Voltage Range	19.2V to 31.2V dc (includes 5% ac ripple)
Communication Rate	5M Bits/s
Indicators	Comm A - red/grn Comm B - red/grn I/O Status - red/grn
Flexbus Output Current	640mA maximum @ 5V dc
Isolation Voltage	500V ac between user power and flexbus
Power Consumption	400mA maximum from external 24V supply
Power Dissipation	4.6W maximum @ 19.2V dc
Thermal Dissipation	15.7 BTU/hr @ 19.2V dc
Environmental Conditions	
Operational Temperature	0 to 55°C (32 to 131°F)
Storage Temperature	-40 to 85°C (-40 to 185°F)
Relative Humidity	5 to 95% noncondensing
Shock	30 g peak acceleration, 11(±1)ms pulse width
Operating	50 g peak acceleration, 11(±1)ms pulse width
Non-operating	Tested 5 g @ 10-500Hz per IEC 68-2-6
Vibration	
ControlNet Cable	Belden RG-6/U
Power Conductors	
Type	Copper
Wire Size	12 gauge (4mm <sup>2</sup> ) stranded maximum 3/64 inch (1.2mm) insulation max.
Category	2 <sup>1</sup>
Connector Screw Torque	7-9 inch-pounds
Agency Certification (when product is marked)	<ul style="list-style-type: none"> <li>• CSA certified</li> <li>• CSA Class I, Division 2 Groups A, B, C, D certified</li> <li>• UL listed</li> <li>• CE marked for all applicable directives</li> </ul>

<sup>1</sup> Use this conductor category information for planning conductor routing. Refer to publication 1770-4.1, "Industrial Automation Wiring and Grounding Guidelines."

## Mounting Dimensions

Inches  
(Millimeters)

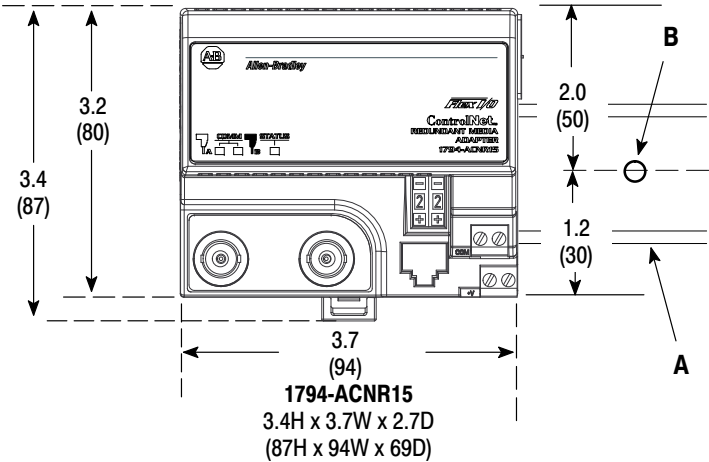

**A** = DIN rail

**B** = Secure DIN rail approximately every 200mm

 **Rockwell Automation**

**Allen-Bradley**

With major offices worldwide.

World Headquarters,  
Allen-Bradley,  
1201 South Second Street,  
Milwaukee, WI 53204 USA,  
Tel: (1) 414 382-2000 Fax: (1) 414 382-4444