



CENTERLINE® 2100 Motor Control Centers Retrofitting Units with Horizontal Operating Handles Into Series "E" Through "J" Sections

Application

This publication details the retrofitting procedure for units with horizontal operating handles that plug into CENTERLINE® 2100 sections with series letters "E" through "J."

Recommended Tools

Screwdriver

Wrenches or sockets in the following sizes: 5/16" and 3/8"

Torque wrench

Preparation

1. Verify parts (shown in Figures 1, 3, 4 on pages 2, 4, 5).

Parts list:

- a. Latch (1)
 - b. Hinges (2)
 - c. 1/4-20 x 1/2 thread-forming screws (2)
 - d. Door hinge pins (2)
 - e. Ground wire (1)
 - f. 10-32 x 3/8 thread-forming screws (2)
2. Check section series letter. **These instructions only apply for sections with series letters "E" through "J."**

Retrofitting Procedure

1. Remove the existing door latch from the unit door and save all hardware to attach the new latch.
2. Assemble the new latch on the door, referring to Figure 1. **Parts must be assembled in the exact sequence and orientation shown in Figure 1.**

Figure 1 Door latch assembly

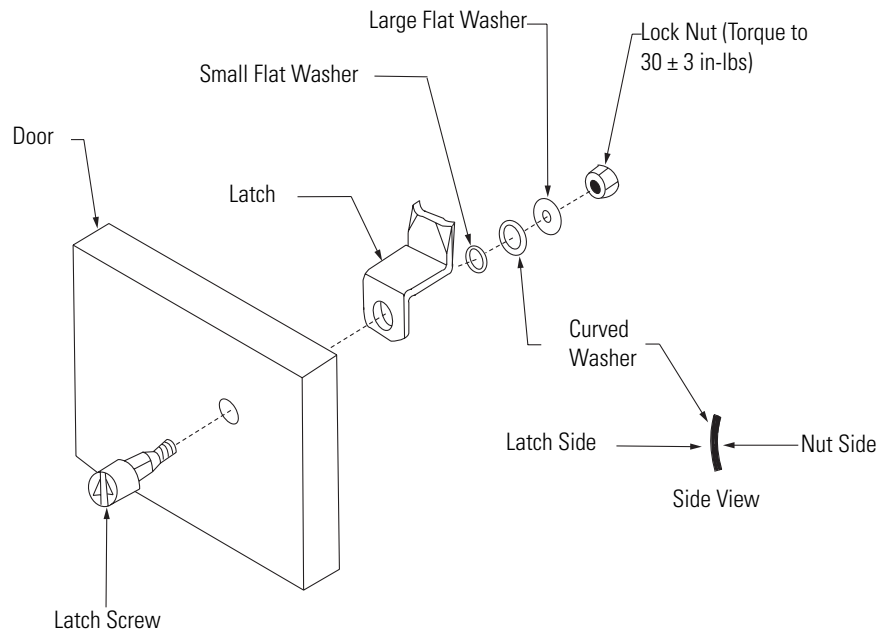

NOTE: Arrow symbol on latch screw must be in line with the latch as shown in Figure 1.

3. Torque the lock nut to 30 lb-in (3.4 N-m).
4. For sections with series letters “E” through “G” only:
 - a. Modify the left front flange of the sidesheet using the full scale template in Figure 2 (page 3).
 - b. Use the 1/4-20 thread-forming screws to mount the hinges on the structure. Position the hinges as shown in Figure 3 (page 4).
 - c. Torque the mounting screws to 45 lb-in (5 N-m).

Figure 2 Full Scale Template to modify series "E" through "G" structures

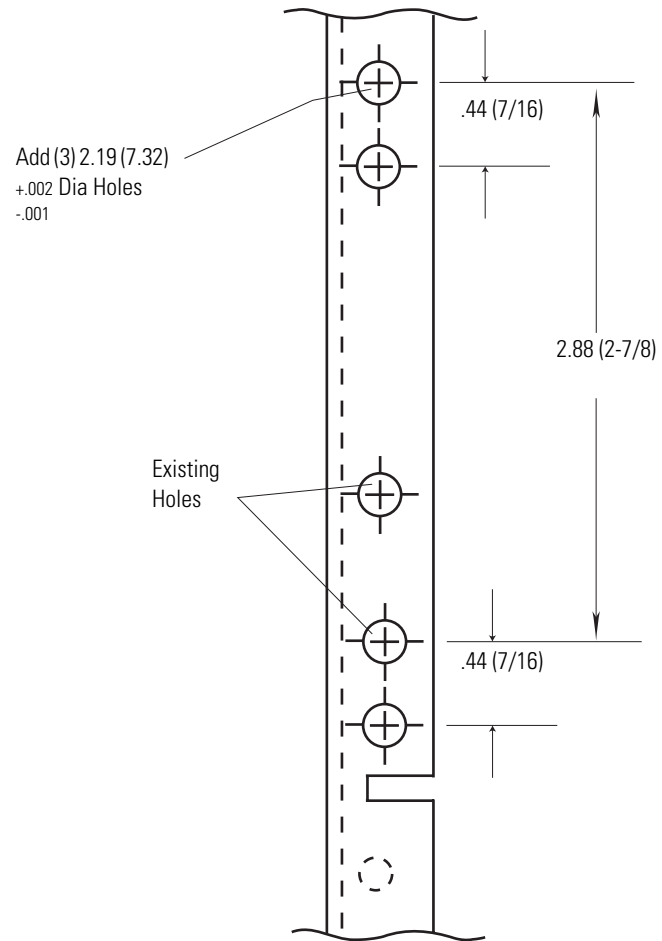
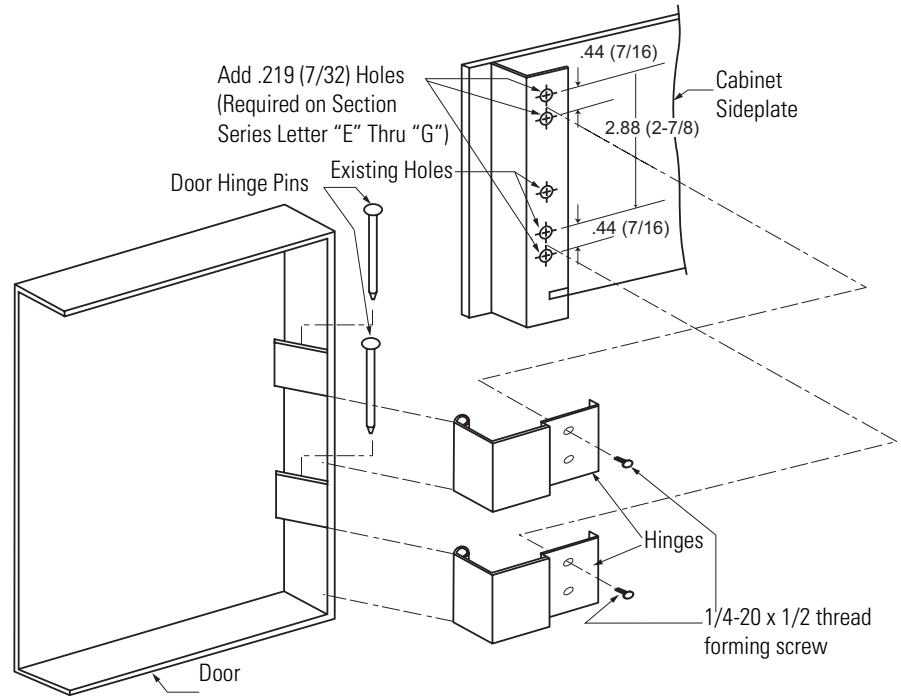

Figure 3 Door hinge assembly



5. Attach one end of the ground wire to the inside of the unit backplate with a 10-32 thread-forming screw. Use the hole at the top, to the left of the stab molding (Figure 4, page 5).

NOTE: This hole may already be used for the ground wire of a transformer. If so, remove the screw which holds the transformer wire, then secure both wires with the 10-32 thread-forming screw. Torque the screw to 32 lb-in (3.6 N-m).

Figure 4 Attaching the ground wire

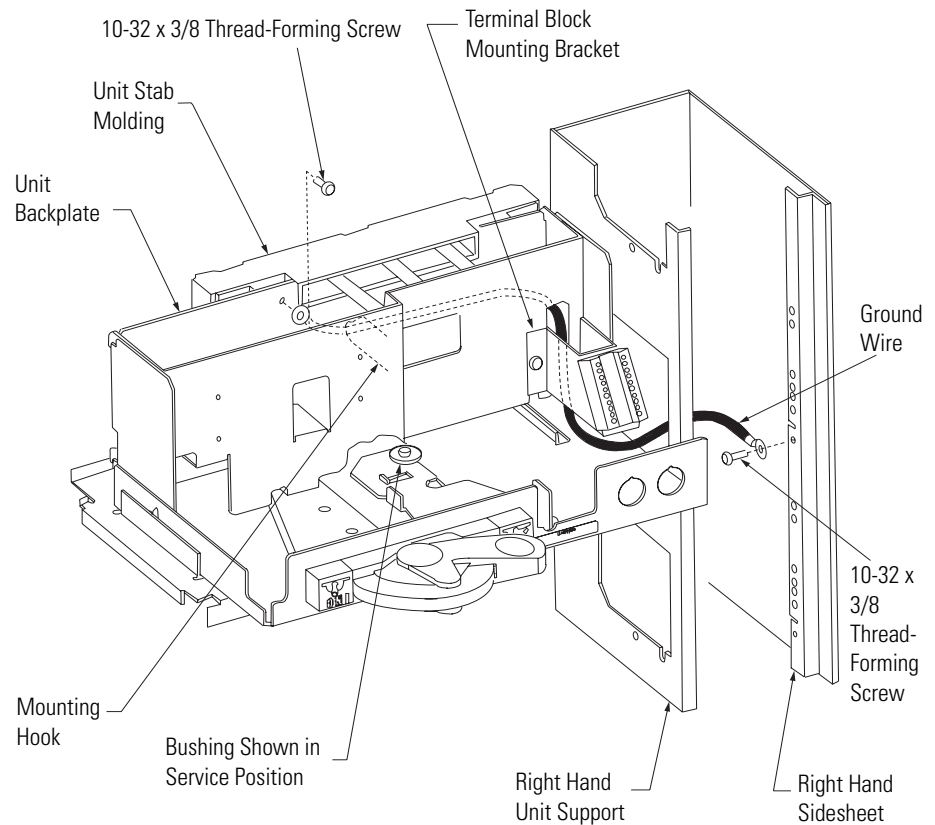

Note: Unit devices have been omitted for clarity.

6. Feed the ground wire, allowing the wire to pass through the opening in the Right Hand Unit Support.

NOTE: Do not route the wire over the top of the mounting plate, as it could be damaged during unit insertion or removal. Refer to Figure 4 for an example of typical routing.

7. Insert the unit to the service position (rear slot in the latch/interlock lever engages the unit support pan bushing). For detailed unit insertion instructions, refer to Publication 2100-IN060x-EN-P, *Installing Units with Horizontal Operating Handles*.

8. Feed the ground wire out the right side of the unit and through the wireway cutout in the right hand unit support. Attach the unsecured end of the wire to the front flange of the sidesheet with a 10-32 thread-forming screw. Use the small hole below the notch that is level with the unit support pan (Figure 4). Torque the screw to 32 lb-in (3.6 N-m).
9. Complete the unit insertion procedure.

NOTE: If large cables are being wired to unit devices, it may be necessary to enlarge the wireway cutout in the right hand unit support for easier access and increased bending room.

10. Mount the door to the structure and insert the hinge pins.

www.rockwellautomation.com

Power, Control and Information Solutions Headquarters

Americas: Rockwell Automation, 1201 South Second Street, Milwaukee, WI 53204-2496 USA, Tel: (1) 414.382.2000, Fax: (1) 414.382.4444

Europe/Middle East/Africa: Rockwell Automation, Vorstlaan/Boulevard du Souverain 36, 1170 Brussels, Belgium, Tel: (32) 2 663 0600, Fax: (32) 2 663 0640

Asia Pacific: Rockwell Automation, Level 14, Core F, Cyberport 3, 100 Cyberport Road, Hong Kong, Tel: (852) 2887 4788, Fax: (852) 2508 1846