

90A Field SCR Module Replacement (for 1250, 1650, and 3000A 1395 DC Drives)

Contents

This document shows how to remove and replace 90A field SCR modules in a 1250, 1650, or 3000A 1395 DC drive.

What This Kit Contains

Using the table below, verify that you have received the appropriate items in your kit:

For this part:	You should receive this quantity:
90A field SCR	2

Other Items Needed

Before you begin, be sure you also have the following:

- Tools needed for:
 - Loosening and tightening screws (slotted and Phillips screwdrivers)
 - Test for voltage (multimeter)
- Documentation:
 - Your drive system schematics
 - Publication 1395-5.40, *Bulletin 1395 Digital DC Drive—User Manual*
 - Publication 2361-5.01, *Bulletin 1395 Digital DC Drive in Bulletin 2361 Motor Control Center for Drive Systems—User Manual*

Safety Precautions

The following general precautions apply when working on drives:



ATTENTION: Only those familiar with the drive system, the products used in the system, and the associated machinery should plan or implement the installation, startup, and future maintenance of the system. Failure to comply can result in personal injury and/or equipment damage.

ATTENTION: Verify that all sources of AC and DC power are deenergized and locked out or tagged out in accordance with the requirements of ANSI/NFPA 70E, Part II.

ATTENTION: The system may contain stored energy devices. To avoid the hazard of electrical shock, verify that all voltage on capacitors has been discharged before attempting to service, repair, or remove a drive system or its components. You should only attempt the procedures in this manual if you are qualified to do so and are familiar with solid-state control equipment and the safety procedures in publication NFPA 70E.

ATTENTION: When servicing any unit, do not drop any nuts, bolts, washers, etc. inside the unit, as they may cause a short circuit on power up.

ATTENTION: This drive system contains ESD (Electrostatic Discharge) sensitive parts and assemblies. Static control precautions are required when installing, testing, or repairing this assembly. Component damage can result if ESD control procedures are not followed. If you are not familiar with static control procedures, refer to Rockwell Automation publication 8000-4.5.2, *Guarding Against Electrostatic Damage* or any other applicable ESD protection handbook.

Special Instructions

Important: You will need to reuse parts that are removed from the drive. Place parts, in the order removed, on a clean surface.

Preliminary Steps

Before replacing field SCR modules, shut off the drive power, wait five minutes for the voltage to discharge, and open the disconnect bay door.

Removing Field SCR Modules

1. Using a voltmeter, test the voltage across the three phases, then across TB7-1 and TB7-3.



ATTENTION: If there is any voltage present, remove the source of the voltage and check for voltages again before proceeding to the next step.

2. Loosen the thumb screws to lower the control board panel.
3. Loosen the thumb screws to lower the feedback board panel.
4. Dismount the field board by unscrewing the six set screws.

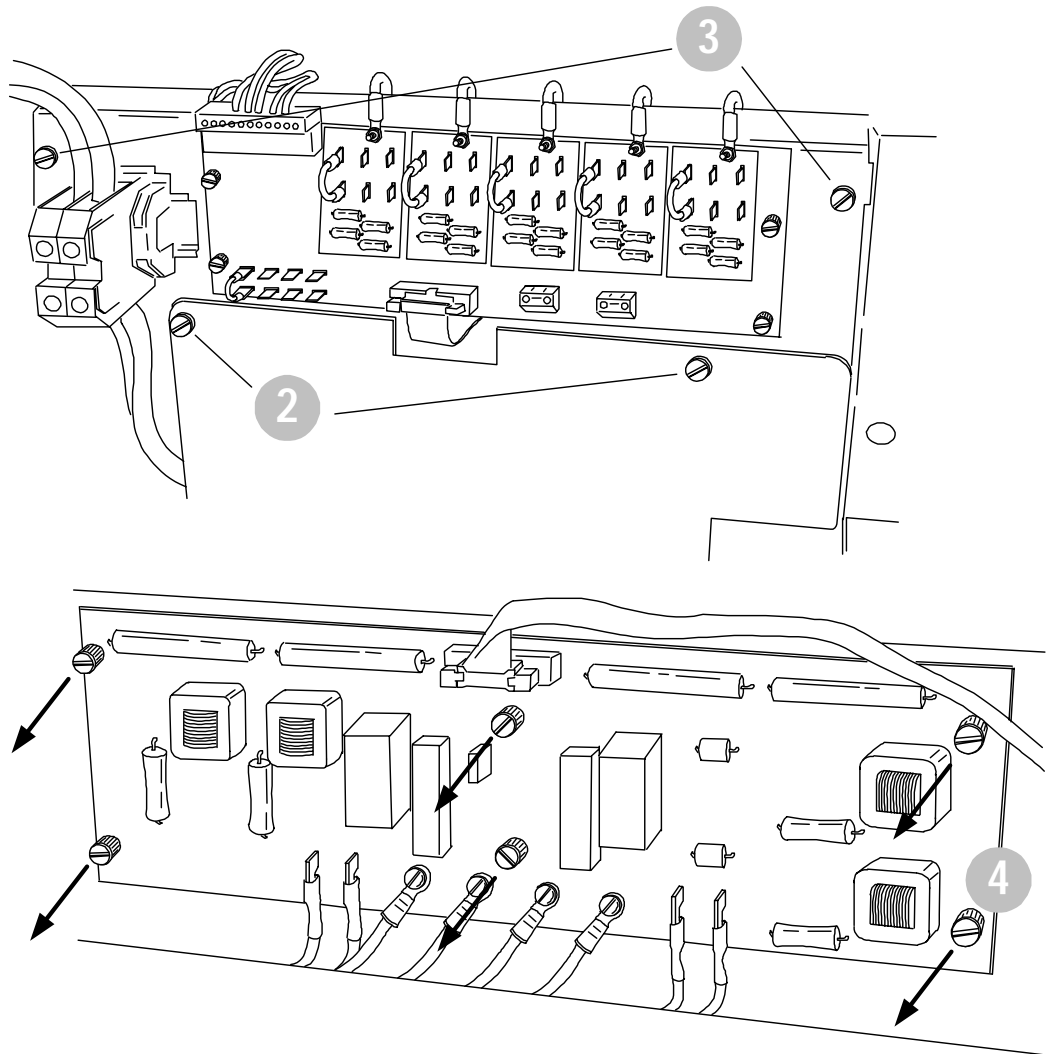

5. Disconnect the gate leads from the SCR modules.
6. Disconnect the busbar connections from the left SCR module by removing the three mounting screws.
7. Remove the two screws which mount the left SCR module and take the module out.

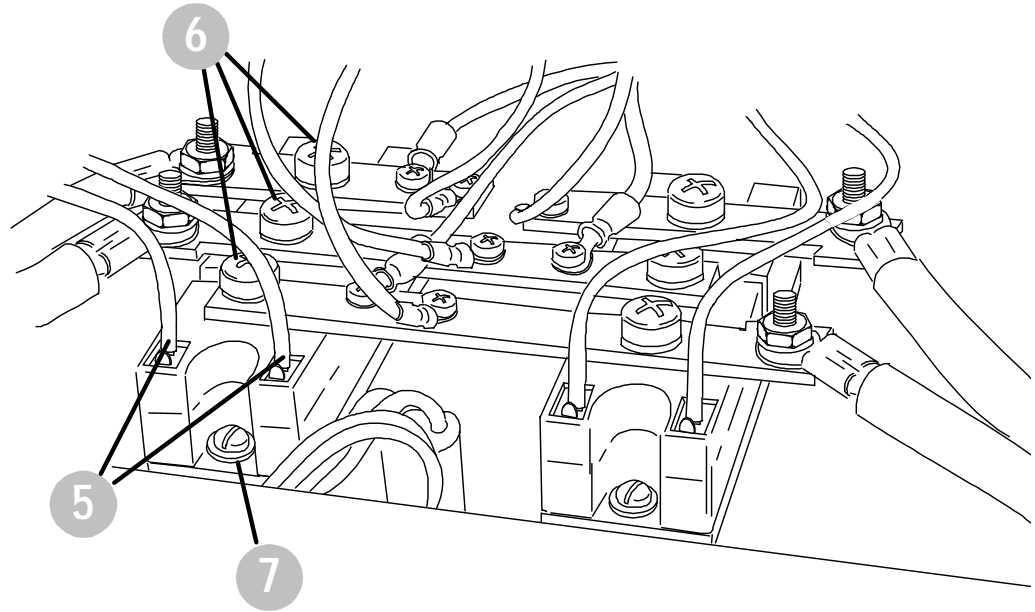

8. Mount the new SCR module by securing the two mounting screws (the gate lead prongs should be to the front). Torque to 45 lb-in.
9. Secure the busbars to the left module with the three mounting screws. Torque to 26 lb-in.

10. Disconnect the busbar connections from the right SCR module by removing the three mounting screws.
11. Remove the two screws which mount the right SCR module and take the module out.

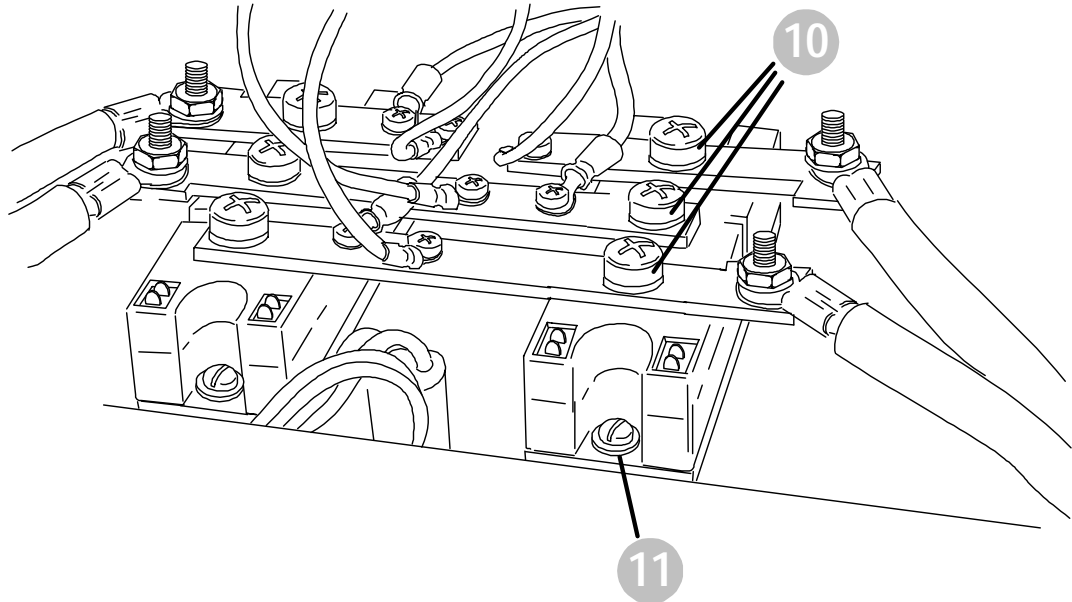

12. Mount the new SCR module by securing the two mounting screws (the gate lead prongs should be to the front). Torque to 45 lb-in.
13. Secure the busbars to the right module with the three mounting screws. Torque to 26 lb-in.
14. Reconnect the gate leads.
15. Mount the field-pulse transformer board by securing the six set screws.

Concluding Steps

After installing the field SCR modules, verify all wiring, secure the panels in the upright position, replace all Lexan™ shielding, and secure the disconnect bay door. Dispose of old parts according to your company procedures and local ordinances.

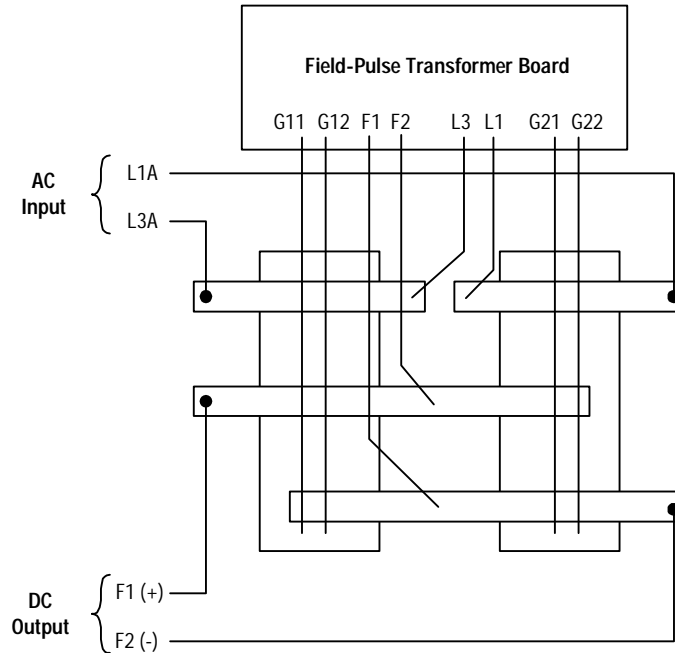

Lexan is a trademark of General Electric Corp.



Rockwell Automation helps its customers receive a superior return on their investment by bringing together leading brands in industrial automation, creating a broad spectrum of easy-to-integrate products. These are supported by local technical resources available worldwide, a global network of system solutions providers, and the advanced technology resources of Rockwell.

Worldwide representation.



Argentina • Australia • Austria • Bahrain • Belgium • Bolivia • Brazil • Bulgaria • Canada • Chile • China, People's Republic of • Colombia • Costa Rica • Croatia • Cyprus • Czech Republic • Denmark • Dominican Republic • Ecuador • Egypt • El Salvador • Finland • France • Germany • Ghana • Greece • Guatemala • Honduras • Hong Kong • Hungary • Iceland • India • Indonesia • Iran • Ireland • Israel • Italy • Jamaica • Japan • Jordan • Korea • Kuwait • Lebanon • Macau • Malaysia • Malta • Mexico • Morocco • The Netherlands • New Zealand • Nigeria • Norway • Oman • Pakistan • Panama • Peru • Philippines • Poland • Portugal • Puerto Rico • Qatar • Romania • Russia • Saudi Arabia • Singapore • Slovakia • Slovenia • South Africa, Republic of • Spain • Sweden • Switzerland • Taiwan • Thailand • Trinidad • Tunisia • Turkey • United Arab Emirates • United Kingdom • United States • Uruguay • Venezuela

Rockwell Automation Headquarters, 1201 South Second Street, Milwaukee, WI 53204 USA, Tel: (1) 414 382-2000, Fax: (1) 414 382-4444

Rockwell Automation European Headquarters SA/NV, avenue Hermann Debrouckere, 46, 1160 Brussels, Belgium, Tel: (32) 2 663 06 00, Fax: (32) 2 663 06 40

Rockwell Automation Asia Pacific Headquarters, 27/F Citicorp Centre, 18 Whitfield Road, Causeway Bay, Hong Kong, Tel: (852) 2867 4788, Fax: (852) 2508 1846