



DC Link Fuse Upgrade Kit for RGU in Parallel with NRU

Contents

This document shows how to install the DC Link Fuse Upgrade Kit for a Regenerative DC Bus Supply (RGU) in parallel with a Non-Regenerative DC Bus Supply (NRU).

What This Kit Contains

There are three styles of kits. The contents of the kit vary to accommodate the size of RGU. Refer to the proper table for your RGU to determine whether you have all the proper parts.

D-Frame Parts

Table A DC Link Fuse Upgrade Kit for D/K Size RGU // NRU (302102)

Description	Mequon P/N	Manufacture P/N	Quantity
Fuse	178004	170M3766	3
Microswitch	178219	170H0069	2
Relay	300635	700-CF220D	1
Suppressor	300362	100-FSV136	1
Red Wire	103859	30614	Approximately 200ft
White Wire	103857	30614	Approximately 50ft
Wire Markers	N/A	N/A	N/A
Fuse Tags	N/A	N/A	N/A
Relay Panel Marker	N/A	N/A	1

E-Frame Parts

Table B DC Link Fuse Upgrade Kit for E/L Size RGU // NRU (302103)

Description	Mequon P/N	Manufacture P/N	Quantity
Fuse	304377	170M5660	3
Microswitch	178219	170H0069	2
Relay	300635	700-CF220D	1
Suppressor	300362	100-FSV136	1
Red Wire	103859	30614	Approximately 200ft
White Wire	103857	30614	Approximately 50ft
Wire Markers	N/A	N/A	N/A
Fuse Tags	N/A	N/A	N/A
Relay Panel Marker	N/A	N/A	1

G and H-Frame Parts

Table C DC Link Fuse Upgrade Kit for G/M or H/N Size RGU // NRU (302104)

Description	Mequon P/N	Manufacture P/N	Quantity
Fuse	304377	170M5660	6
Microswitch	178219	170H0069	4
Relay	300635	700-CF220D	1
Suppressor	300362	100-FSV136	1
Red Wire	103859	30614	Approximately 200ft
White Wire	103857	30614	Approximately 50ft
Wire Markers	N/A	N/A	N/A
Fuse Tags	N/A	N/A	N/A
Relay Panel Marker	N/A	N/A	1

Other Items Needed

Before you begin, be sure to have the following:

- Tools for:
 - Tightening screws (including terminal screws) and bolts
 - Stripping wire
 - Measuring voltages (115-460Vac, and 24-720Vdc)
- Documentation:
 - Drive system schematics

Safety Precautions

The following general precautions apply when servicing drives:



ATTENTION: Only those familiar with the drive system, the products used in the system, and the associated machinery should plan or implement the installation, startup, and future maintenance of the system. Failure to comply can result in personal injury and/or equipment damage.

ATTENTION: Verify that all sources of AC and DC power are de energized and locked out and tagged out in accordance with the requirements of ANSI/NFPA 70E, Part II.

ATTENTION: The system may contain stored energy devices. To avoid the hazard of electrical shock, verify that all voltage on capacitors has been discharged before attempting to service, repair, or remove a drive system or its components. You should only attempt the procedures in this manual if you are qualified to do so and are familiar with solid-state control equipment and the safety procedures in publication NFPA 70E.

ATTENTION: Nuts, bolts, washers, metal drillings, etc. may create short circuits within the unit. This can result in personal injury and/or equipment damage. Avoid dropping any of these in the unit. Cover controls below drilling areas. Remove drillings with a vacuum or magnet.

ATTENTION: This drive system contains ESD (Electrostatic Discharge) sensitive parts and assemblies. Static control precautions are required when installing, testing, or repairing this assembly. Component damage can result if ESD control procedures are not followed. If you are not familiar with static control procedures, refer to Rockwell Automation publication 8000-4.5.2, *Guarding Against Electrostatic Damage* or any other applicable ESD protection handbook.

Preliminary Steps

Before installing the upgrade kit, verify that all sources of AC and DC power are de energized and locked out and tagged out. Wait five minutes for all stored energy to dissipate. Using a meter measure the voltage across the three phases of AC line power. Using a meter measure the voltage on the DC bus. Proceed only when these voltages equal 0V.

Mounting New Relay

The component designator for the new relay is CR5. The mounting location varies by RGU size. In every case the relay mounts in the control bay. Refer to the diagram associated with your RGU.

Important: Remember to install the suppressor across the relay's coil. Also remember to install the new relay's panel marker (component tag).

D-Frame -

Mount the new relay (CR5) in the control bay - just to the left of CR4 and just below M2.

Figure 1 Mounting New Relay On D-Frame RGU

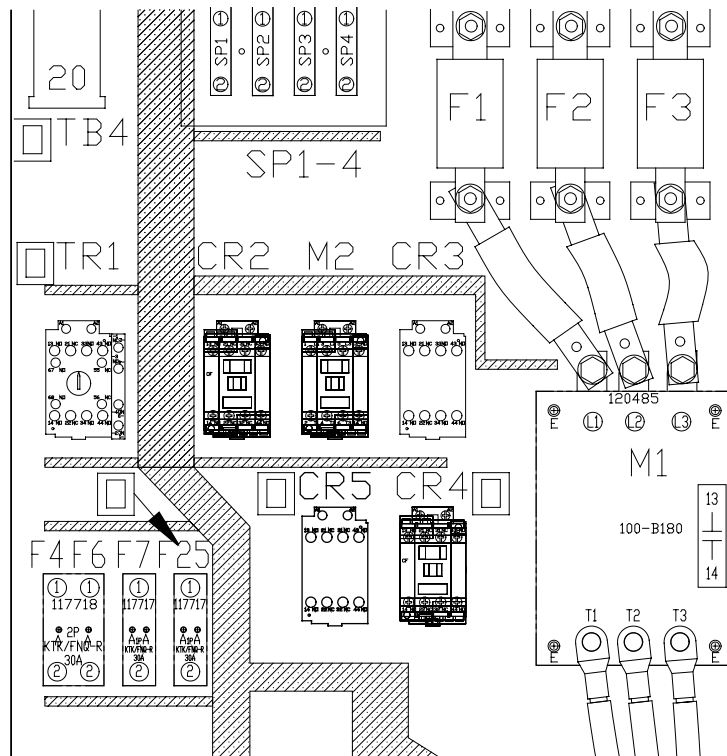

E-Frame -

Mount the new relay (CR5) in the control bay - just to the left of CR4 and just below TR1.

Figure 2 Mounting New Relay On E-Frame RGU

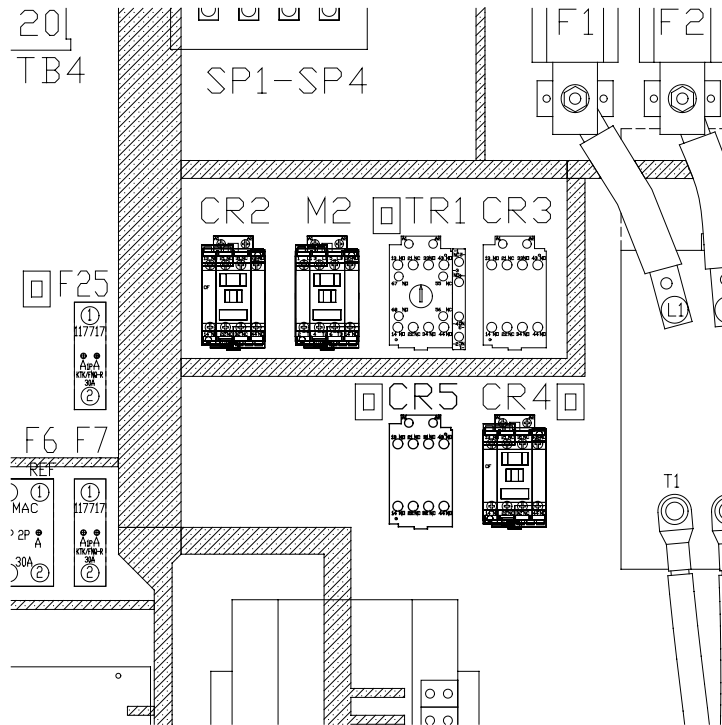

G-Frame -

Mount the new relay (CR5) in the control bay - just to the left of TR1 and just below CR2.

Figure 3 Mounting New Relay In G-Frame RGU

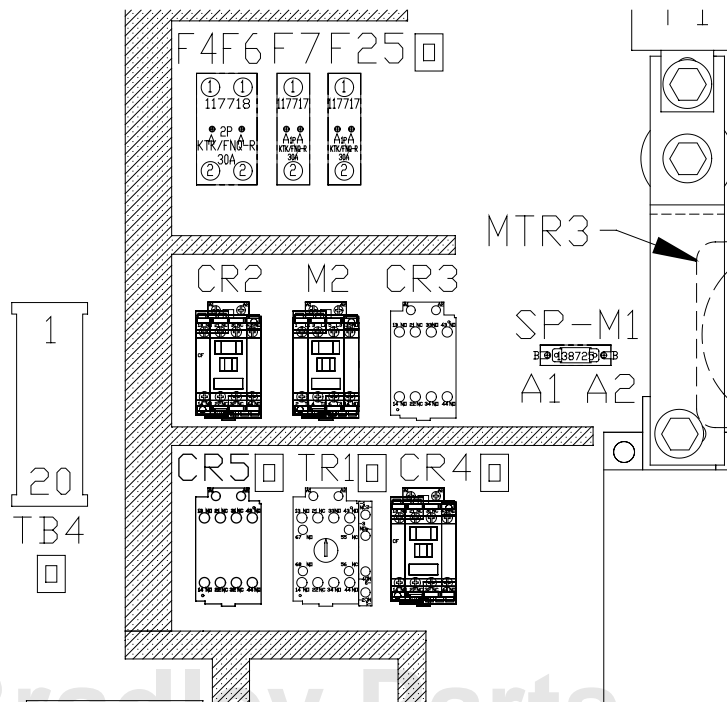

H-Frame -

Mount the new relay (CR5) in the control bay - just to the left of CR4 and just below TR1.

Figure 4 Mounting New Relay In H-Frame RGU

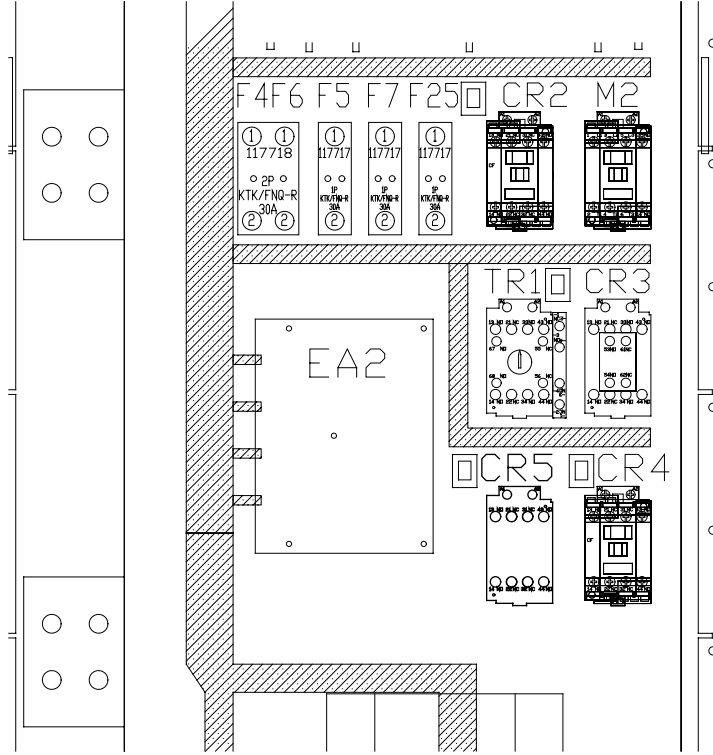

Mounting New Fuses

D-Frame and E-Frame Fuse Replacement

Figure 5 Fuse Location In RGU With Two Fuses

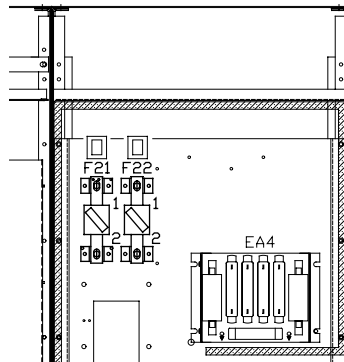

1. Locate the fuses on the top of the power structure bay (the right-hand bay). D-Frame and E-Frame RGUs have two output fuses (one for DC+ and another for DC-). The component designators are F21 and F22. [Figure 5](#) illustrates the fuse location in an RGU with two fuses.
2. Remove the nut and washers from each pole of the fuse holder. Note the orientation of this hardware. Some washers such as clamp and Bellville have only one correct orientation for installation. Place these parts in the order removed, on a clean surface. You will need to reuse these parts.
3. Remove the old fuse and install the new one.
4. Re-install the mounting hardware in the correct orientation. Tighten the nut with 16 lb.-ft. of torque.
5. Replace the old fuse tag with the new one.
6. Repeat for the second fuse.

G-Frame and H-Frame Fuse Replacement

Figure 6 Fuse Location In RGU With Four Fuses

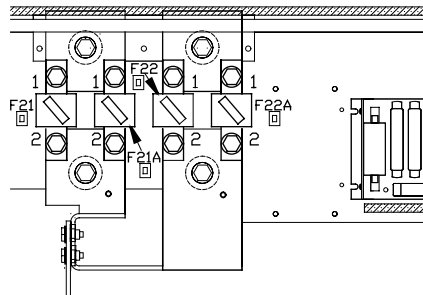

1. Locate the fuses on the top of the power structure bay (the right-hand bay). G-Frame and H-Frame RGUs have four output fuses (two for DC+ and two for DC-). The component designators are F21, F21A, F22 and F22A. [Figure 6](#) illustrates the fuse location in an RGU with four fuses.
2. Remove the bolt, nut and washers from each pole of the fuse. Note the orientation of this hardware. Some washers such as clamp and Bellville have only one correct orientation for installation. Place these parts in the order removed, on a clean surface. You will need to reuse these parts.
3. Remove the old fuse and install the new one.
4. Re-install the mounting hardware in the correct orientation. Tighten the nut with 45 lb.-ft. of torque.
5. Replace the old fuse tag with the new one.
6. Repeat for the other fuses.

Wiring the New Circuit

Important: Use the enclosed stranded 14 gage wire (Belden 30614 or equivalent). Use the red wire for 115Vac signals and the white wire for 115Vac neutral. Use the enclosed wire tags.

1. Connect the normally closed Microswitch contacts (contacts that open when the fuses blow) on the fuses in series with the new relay coil (CR5). The normally closed contact is between terminal 1 and 2 on each Microswitch. [Figure 7](#) defines the terminals on the Microswitch. [Figure 8](#) illustrates the contacts inside the Microswitch. Refer to [Figure 9](#) for RGUs with two fuses. Refer to [Figure 10](#) for RGUs with four fuses.

Figure 7 Microswitch Terminals

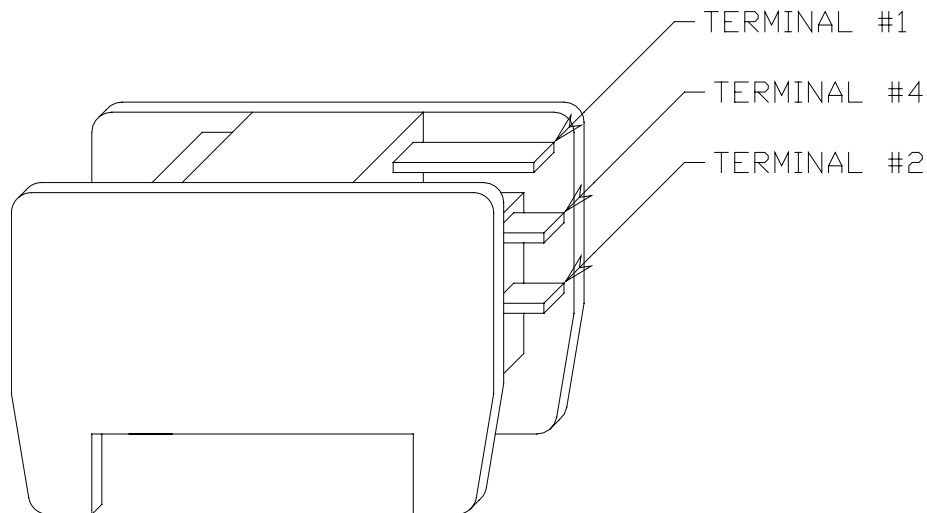

Figure 8 Microswitch Contacts

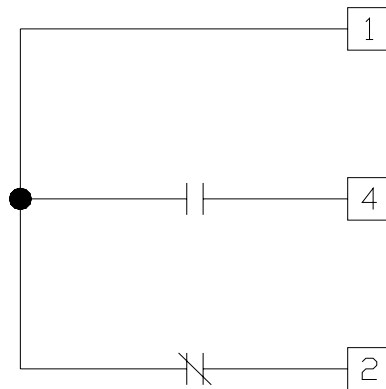

Figure 11 New Relay Contacts In Enable and External Not Fault Circuits

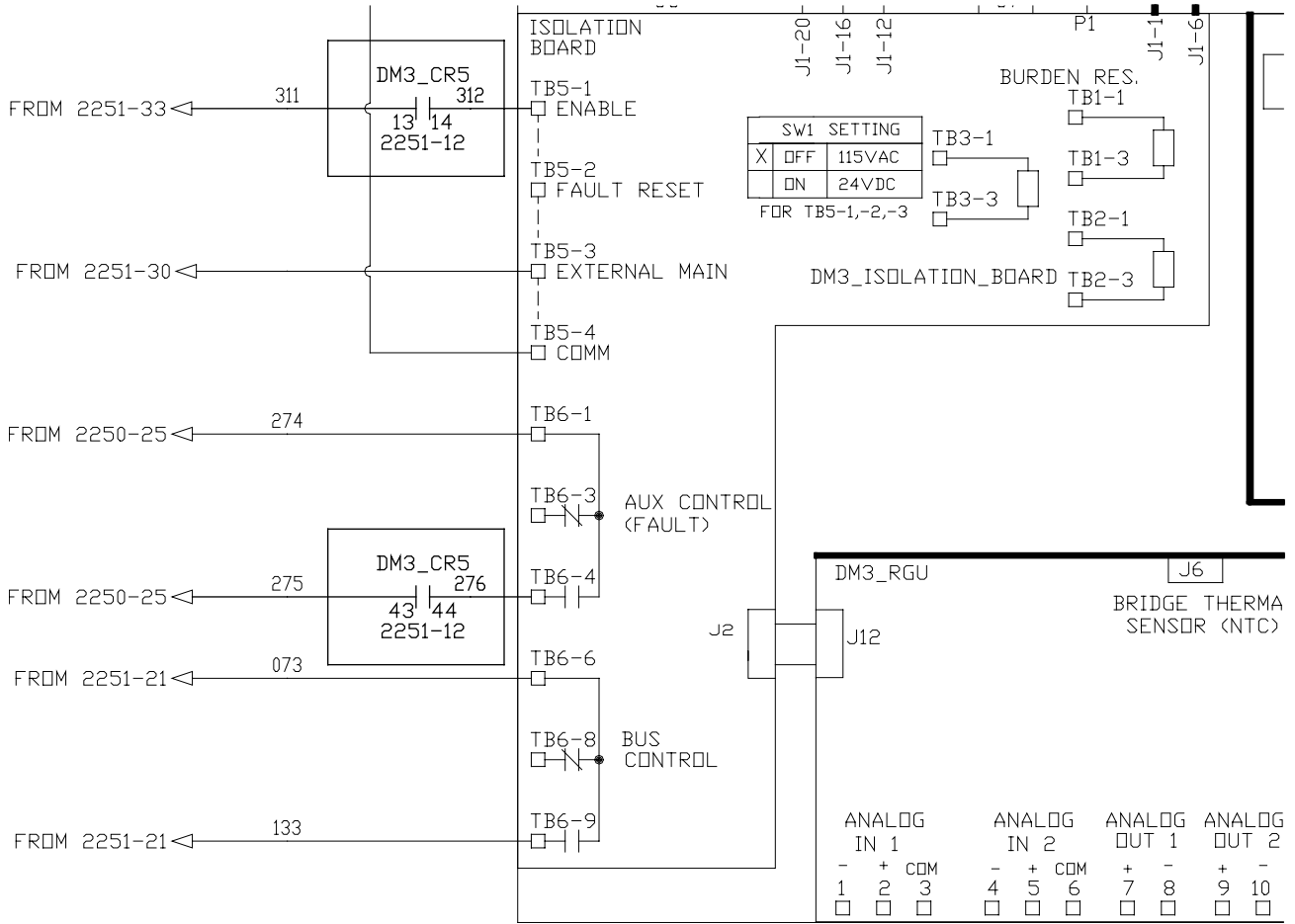
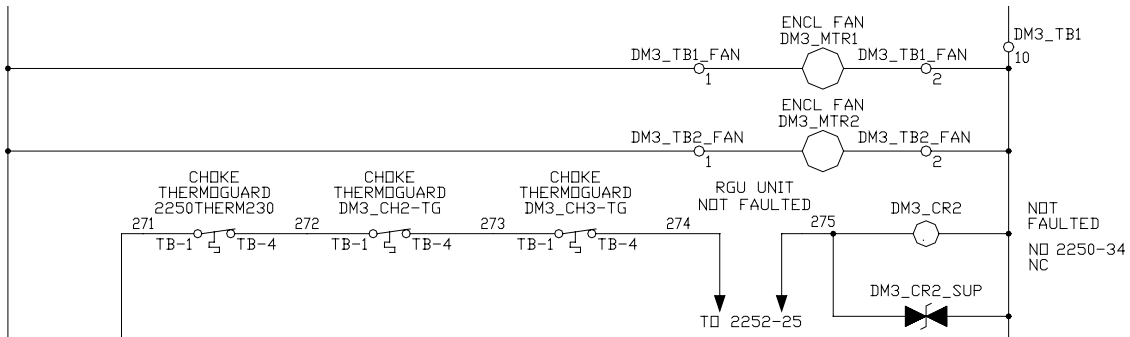

Figure 12 External Not Fault Circuit That Uses New Contact



TIP: This leaves two normally closed CR5 contacts (contacts that open when the relay energizes) for annunciation. A PLC input could consume a signal controlled by one of these contacts.

Testing

- Energize the unit
- Remove wire 117 or 119 from the coil of the relay. Use caution when handling energized wires!
- The unit should stop modulating and indicate a fault
- De-energize the unit
- Replace the wire
- Re-energize the unit

Make Mark-Ups

Use a red pen to add circuitry to copies of drive system schematics. Leave one copy of marked-ups on site.

The mark-ups should indicate the number of the kit (the part number shown in tables on pages 1 or 2) used for the upgrade.

Send Mark-Ups To Headquarters

Send one copy of the mark-ups to Drive Systems headquarters.

Attention: Robert VanLieshout

Allen-Bradley Drive Systems

6400 West Enterprise Drive

Mequon, WI 53092

Allen-Bradley Drive Systems will use these mark-ups to provide “as installed” drawings to customers.

Allen-Bradley Drive Systems will also use the receipt mark-ups to track which sites have received the update.

Reach us now at www.rockwellautomation.com

Wherever you need us, Rockwell Automation brings together leading brands in industrial automation including Allen-Bradley controls, Reliance Electric power transmission products, Dodge mechanical power transmission components, and Rockwell Software. Rockwell Automation's unique, flexible approach to helping customers achieve a competitive advantage is supported by thousands of authorized partners, distributors and system integrators around the world.

Americas Headquarters, 1201 South Second Street, Milwaukee, WI 53201-2496, USA, Tel: (1) 414 382-2000, Fax: (1) 414 382-4444

European Headquarters SA/NV, Boulevard du Souverain 36, 1170 Brussels, Belgium, Tel: (32) 2 663 0600, Fax: (32) 2 663 0640

Asia Pacific Headquarters, 27/F Citicorp Centre, 18 Whitfield Road, Causeway Bay, Hong Kong, Tel: (852) 2887 4788, Fax: (852) 2508 1846

