

Adapter Plate Kit for PanelView 800, 7-inch and 10-inch Terminals

Catalog Numbers 2711R-APK7, 2711R-APK10

Topic	Page
About This Publication	1
Package Contents	3
Tools Required	3
Disconnect the Terminal	3
Attach the Adapter Plate to the Panel	4
Attach the Terminal to the Adapter Plate	5

About This Publication

This document provides instructions on how to mount a PanelView 800 terminal using an adapter plate into an existing cutout. The PanelView 800 7-inch terminal mounts to the 2711R-APK7 cutout adapter and the 10-inch terminal mounts to the 2711R-APK10 cutout adapter.

Important User Information

Solid-state equipment has operational characteristics differing from those of electromechanical equipment. Safety Guidelines for the Application, Installation and Maintenance of Solid State Controls (Publication [SGI-1.1](#) available from your local Rockwell Automation sales office or online at <http://www.rockwellautomation.com/literature/>) describes some important differences between solid-state equipment and hard-wired electromechanical devices. Because of this difference, and also because of the wide variety of uses for solid-state equipment, all persons responsible for applying this equipment must satisfy themselves that each intended application of this equipment is acceptable.





In no event will Rockwell Automation, Inc. be responsible or liable for indirect or consequential damages resulting from the use or application of this equipment.

The examples and diagrams in this manual are included solely for illustrative purposes. Because of the many variables and requirements associated with any particular installation, Rockwell Automation, Inc. cannot assume responsibility or liability for actual use based on the examples and diagrams.

No patent liability is assumed by Rockwell Automation, Inc. with respect to use of information, circuits, equipment, or software described in this manual.

Reproduction of the contents of this manual, in whole or in part, without written permission of Rockwell Automation, Inc., is prohibited.

Throughout this manual, when necessary, we use notes to make you aware of safety considerations.

	WARNING: Identifies information about practices or circumstances that can cause an explosion in a hazardous environment, which may lead to personal injury or death, property damage, or economic loss.
	ATTENTION: Identifies information about practices or circumstances that can lead to personal injury or death, property damage, or economic loss. Attentions help you identify a hazard, avoid a hazard and recognize the consequences.
	SHOCK HAZARD: Labels may be on or inside the equipment (for example, drive or motor) to alert people that dangerous voltage may be present.
	BURN HAZARD: Labels may be on or inside the equipment (for example, drive or motor) to alert people that surfaces may reach dangerous temperatures.
IMPORTANT	Identifies information that is critical for successful application and understanding of the product.

Package Contents

The Cutout Adapter Kit includes:

- A cutout adapter plate with waterproof gasket
- #8-32 nuts with lock washers (6 sets)
- Thin mounting levers (8)

Thin mounting lever

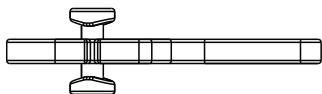

Regular mounting lever

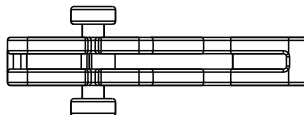

IMPORTANT Thin mounting levers are only included with 2711R-APK7 and are for use with 2711R-T7T. There are no mounting levers included with 2711R-APK10. Use the regular mounting levers that come with 2711R-T10T.

Tools Required

The following tools are required for installation:

- Socket driver with 11/32-inch socket
- Torque wrench capable of 1.36 Nm (12 in-lb) torque

Disconnect the Terminal

1. Disconnect power at the source and remove the power cord from the PanelView terminal.
2. Disconnect all communication cables from the terminal.



ATTENTION: Make sure the power cord and all communication cables have been disconnected from the PanelView terminal.

Remove the Existing Terminal

1. Remove the self-locking levers that secure the terminal to the panel.
2. Slide the existing terminal out from the panel.

Attach the Adapter Plate to the Panel

1. Align the studs on the cutout adapter plate with the existing stud holes on the front of the panel.
2. Place the adapter plate into the front of the panel cutout until the sealing gasket material is firmly pressed against the front of the panel.

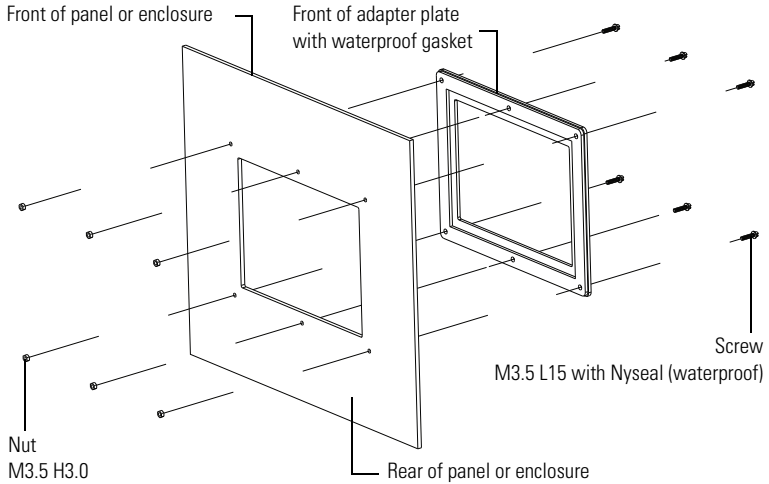

3. Using the supplied nuts with lock washers, fasten the cutout plate onto the studs until the sealing gasket is slightly compressed against the front of the panel.
4. Using the torque wrench, tighten the nuts to not more than 1.36 Nm (12 in-lb) to maintain a NEMA Type 4X, 12, or 13 rating. Do not overtighten.

Attach the Terminal to the Adapter Plate

1. Insert the new terminal into the front of the enclosure until the terminal gasket is flush with the adapter plate.

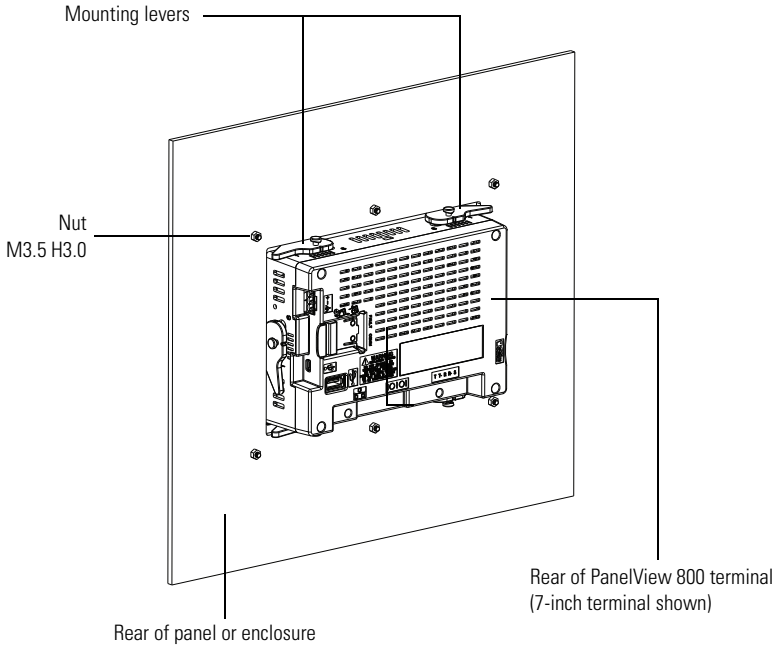

6 Adapter Plate Kit for PanelView 800, 7-inch and 10-inch Terminals

2. Insert all mounting levers into the mounting slots of the terminal.
Slide each lever until the flat side of the lever touches the surface of the panel.

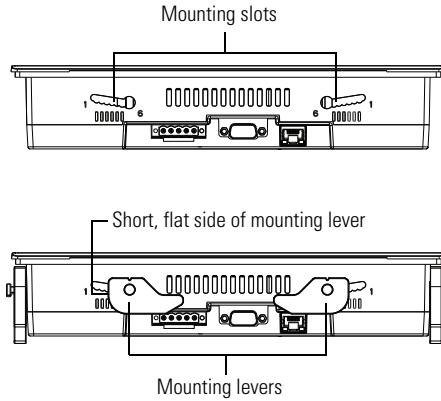

IMPORTANT Use thin mounting levers only when using the 2711R-T7T terminal with the adapter plate.

3. When all levers are in place, slide each lever an additional notch or two until you hear a click.
4. Rotate each lever in the direction indicated until lever is in the final latch position. Follow the latching sequence below to obtain the optimum terminal fit.

Rotate until notch in lever aligns with proper alignment mark on terminal.

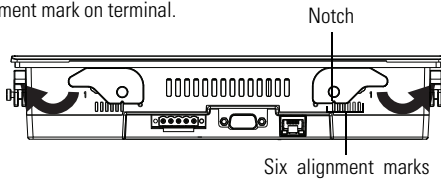

Latching sequence for 2711R-T7T

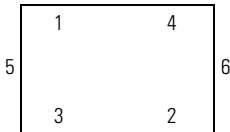

Latching sequence for 2711R-T10T

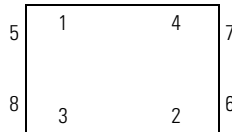

5. Use this table as a guide to insure an adequate gasket seal between the terminal and the panel.

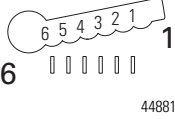
Terminal Markings for Alignment	Lever Position	Panel Thickness Range	Typical Gauge
 <p>44881</p>	1	1.52...2.01 mm (0.060...0.079 in.)	16
	2	2.03...2.64 mm (0.08...0.104 in.)	14
	3	2.67...3.15 mm (0.105...0.124 in.)	12
	4	3.17...3.66 mm (0.125...0.144 in.)	10
	5	3.68...4.16 mm (0.145...0.164 in.)	8/9
	6	4.19...4.75 mm (0.165...0.187 in.)	7



ATTENTION: Follow the instructions above to obtain a proper seal and to prevent potential damage to the terminal. Rockwell Automation assumes no responsibility for water or chemical damage to the terminal or other equipment within the enclosure because of improper installation.

Rockwell Automation Support

Rockwell Automation provides technical information on the Web to assist you in using its products. At <http://www.rockwellautomation.com/support/>, you can find technical manuals, a knowledge base of FAQs, technical and application notes, sample code and links to software service packs, and a MySupport feature that you can customize to make the best use of these tools.

For an additional level of technical phone support for installation, configuration and troubleshooting, we offer TechConnect support programs. For more information, contact your local distributor or Rockwell Automation representative, or visit <http://www.rockwellautomation.com/support/>.

Installation Assistance

If you experience a problem within the first 24 hours of installation, please review the information that's contained in this manual. You can also contact a special Customer Support number for initial help in getting your product up and running.

United States or Canada	1.440.646.3434
Outside United States or Canada	Use the Worldwide Locator at http://www.rockwellautomation.com/support/americas/phone_en.html , or contact your local Rockwell Automation representative.

New Product Satisfaction Return

Rockwell Automation tests all of its products to ensure that they are fully operational when shipped from the manufacturing facility. However, if your product is not functioning and needs to be returned, follow these procedures.

United States	Contact your distributor. You must provide a Customer Support case number (call the phone number above to obtain one) to your distributor to complete the return process.
Outside United States	Please contact your local Rockwell Automation representative for the return procedure.

Documentation Feedback

Your comments will help us serve your documentation needs better. If you have any suggestions on how to improve this document, complete this form, publication [RA-DU002](#), available at <http://www.rockwellautomation.com/literature/>.

Rockwell Automation maintains current product environmental information on its website at <http://www.rockwellautomation.com/rockwellautomation/about-us/sustainability-ethics/product-environmental-compliance-page>.

Rockwell Otomasyon Ticaret A.Ş., Kar Plaza İş Merkezi E Blok Kat:6 34752 İçerenköy, İstanbul, Tel: +90 (216) 5698400

www.rockwellautomation.com

Power, Control and Information Solutions Headquarters

Americas: Rockwell Automation, 1201 South Second Street, Milwaukee, WI 53204-2496 USA, Tel: (1) 414.382.2000, Fax: (1) 414.382.4444
Europe/Middle East/Africa: Rockwell Automation, Vorstlaan/Boulevard du Souverain 36, 1170 Brussels, Belgium, Tel: (32) 2 663 0600, Fax: (32) 2 663 0640
Asia Pacific: Rockwell Automation, Level 14, Core F, Cyberport 3, 100 Cyberport Road, Hong Kong, Tel: (852) 2887 4788, Fax: (852) 2508 1846

Publication 2711R-IN002A-EN-P - March 2015

PN-300378

Copyright © 2015 Rockwell Automation, Inc. All rights reserved. Printed in China.