



MobileView Machine Terminal and Guard Terminal Firmware Upgrade Kit

This document provides instructions on how to upgrade the OS from Win CE 3.0 to Win CE 4.X and install RSVIEW Machine Edition Runtime Station v3.10. The upgrade requires you to:

- copy all the files from the Upgrade folder on the CD to a PC card.
- place the Certificate of Authenticity (COA) label on your terminal to be Microsoft compliant.

Before you begin, determine what revision MobileView terminal you have by looking at the nameplate located on the rear of the unit. If you have a rev D unit, go to Rev D Upgrade Instructions below; otherwise, go to Rev C and Earlier Upgrade Instructions on page 2.

Contents of the Firmware Upgrade Kit

The Firmware Upgrade Kit contains the following:

- (1) CD containing the necessary files to perform the upgrade.
- (1) Certificate of Authenticity (COA) label for Microsoft compliance
- (1) End User License Agreement (EULA).
- These installation instructions

Rev D Upgrade Instructions

1. Copy all the files from the Upgrade folder on the CD (Variant-Update-Tool.exe, KetopAPI.dll, softreset.exe, InstallCE_MOV~.exe, and the *.bin file) to a PC card.
2. Back-up any files from folder Flash Storage that you want to keep to a PC card or to a PC using Microsoft's ActiveSync.
3. Go to Start\Programs\MobileView\MV Configuration Tool. When the config tool appears, go to the Image Update tab. Click the "Image File.." button.

Spare Allen-Bradley

4. Browse to the PC card and select the *.bin file. Click O.K. and then click the “Start Update” button.
5. Select Yes to the next two warnings. After the progress bar completes, you will be prompted to select O.K. to reboot the terminal. Select O.K.

IMPORTANT

Do not remove power from the unit until it boots into the new Operating System.

6. After the unit reboots, a green progress bar will appear and the message “erasing PSM, please wait...”. After the progress bar completes, the unit will go blank for about 15 seconds and then boot into the new OS.
7. A touch screen calibration screen will also appear. The OS update is now complete.
8. After performing the calibration, wait 5 to 10 minutes before doing a registry back-up to save the new touch screen settings; the unit is still writing some files at this point. After doing the registry back-up, you are now ready to load ME Station.

Rev C and Earlier Upgrade Instructions

1. Copy all the files from the Upgrade folder on the CD (Variant-Update-Tool.exe, KetopAPI.dll, softreset.exe, InstallCE_MOV~.exe, and the *.bin file) to a PC card.
2. Back-up any files from folder Flash Storage that you want to keep to a PC card or to a PC using Microsoft’s ActiveSync.
3. Browse to \windows\startup and delete file StartAPI.
4. Browse to the PC card and run softreset.exe.
5. After the unit resets, close the Terminal Server Client message box. Click on Start and then Run command.
6. Browse to the PC card and select Variant-Update-Tool.exe. Then add a space and /variant to the end of the executable. The Run command line should look like this: “Storage Card\Variant-Update-Tool.exe” /variant. Hit OK to execute the command.

7. A config tool will appear. Arrow to the far right tab called Variant Data and select it. Find the five numbers on the nameplate next to Mat No. Type these five numbers in the box to the left of the Set button and then click Set.
8. New values will be written to the screen and to the EEPROM. Click O.K. to accept the new values.
9. Click on Start and then Run command.
10. Hit O.K. to launch the image update tool again. When the config tool appears, go to the Image Update tab. Click the "Image File.." button. Browse to the PC card and select the *.bin file. Click O.K. and then click the "Start Update" button.
11. Select Yes to the next two warnings. After the progress bar completes, you will be prompted to select O.K. to reboot the terminal. Select O.K.

IMPORTANT

Do not remove power from the unit until it boots into the new Operating System.

12. The reboot message may not appear on some units. If this occurs, several minutes after the progress bar has indicated a completion, a screen will come up indicating an EEPROM write failure. Press the Info tab down in the task bar to bring up the terminal reboot message prompt. Select O.K. to reboot the terminal.
13. After the unit reboots, a green progress bar will appear and the message "erasing PSM, please wait...". After the progress bar completes, the unit will go blank for about 15 seconds and then boot into the new OS. A touch screen calibration screen will also appear. The OS update is now complete.
14. After performing the calibration, wait 5 to 10 minutes before doing a registry back-up to save the new touch screen settings; the unit is still writing some files at this point. After doing the registry back-up, you are now ready to load ME Station.

ME Station Install Instructions

Browse to the PC card and launch the InstallCE_MOV~.exe. Once the install is complete, you will be prompted to reboot the terminal. Once the terminal reboots, a ME Station shortcut will appear on the desktop.

Placement of the COA Label

A Certificate of Authenticity (COA) label is included in the kit. You must place this label on the MobileView once it's been upgraded to be Microsoft compliant. The illustration below shows the appropriate location on the MobileView to place the COA label.

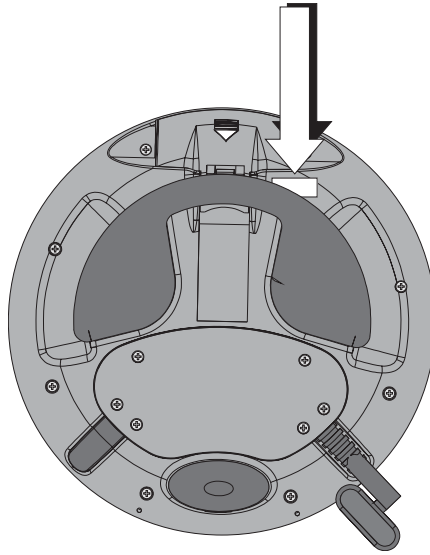

www.rockwellautomation.com

Corporate Headquarters

Rockwell Automation, 777 East Wisconsin Avenue, Suite 1400, Milwaukee, WI, 53202-5302 USA, Tel: (1) 414.212.5200, Fax: (1) 414.212.5201

Headquarters for Allen-Bradley Products, Rockwell Software Products and Global Manufacturing Solutions

Americas: Rockwell Automation, 1201 South Second Street, Milwaukee, WI 53204-2496 USA, Tel: (1) 414.382.2000, Fax: (1) 414.382.4444

Europe: Rockwell Automation SA/NV, Vorstlaan/Boulevard du Souverain 36-BP 3A/B, 1170 Brussels, Belgium, Tel: (32) 2 663 0600, Fax: (32) 2 663 0640

Asia Pacific: Rockwell Automation, 27/F Citicorp Centre, 18 Whitfield Road, Causeway Bay, Hong Kong, Tel: (852) 2887 4788, Fax: (852) 2508 1846

Headquarters for Dodge and Reliance Electric Products

Americas: Rockwell Automation, 6040 Ponders Court, Greenville, SC 29615-4617 USA, Tel: (1) 864.297.4900, Fax: (1) 864.281.2433

Europe: Rockwell Automation, Brühlstraße 22, D-74834 Elztal-Dallau, Germany, Tel: (49) 6261 9410, Fax: (49) 6261 17741

Asia Pacific: Rockwell Automation, 55 Newton Road, #11-01/02 Revenue House, Singapore 307987, Tel: (65) 351 6723, Fax: (65) 355 1733

Publication 2727-IN009A-EN-P - May 2004

PN 41061-355-01(1)

Copyright © 2004 Rockwell Automation, Inc. All rights reserved. Printed in the U.S.A.